



SAM AMBALAJ
Plastik Nakliyat Hafriyat İnşaat San.ve Tic.Ltd.Şti.



SAM AMBALAJ

CORPORATE PRESENTATION



SAM AMBALAJ
Plastik Nakliyat Hafriyat Insaat San.ve Tic.Ltd.Şti.

ENVIRONMENTALLY FRIENDLY PERSPECTIVE



SAM AMBALAJ
Plastik Nakliyat Hafriyat İnşaat San.ve Tic.Ltd.Şti.

ABOUT US

We offer high quality strong and suitable big bags for a wide variety of applications.

Our big bags help you save time, reduce transportation costs and simplify the loading process.



SAM AMBALAJ
Plastik Nakliyat Hafriyat Inaat San.ve Tic.Ltd.Şti.

SAM AMBALAJ

- 1 FAST RELIABLE AND ON TIME DELIVERY
- 2 COMPETITIVE PRICES.
- 3 SUPERIOR SERVICE APPROACH AND HIGH QUALITY.



SAM AMBALAJ
Plastik Nakliyat Hafriyat İnşaat San.ve Tic.Ltd.Şti.

Sam Ambalaj Packaging

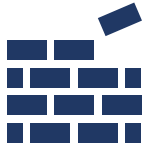

Established in 1995



More than 250.000 big bags
capacity monthly



More than 200 workers



Integrated Production



SAM AMBALAJ, is one of the
major producers of synthetic
woven polypropylene big bags
in Turkey.

Product Portfolio







- 1 Yarn
- 2 Fabric
- 3 Laminated Fabric
- 4 Big bag
- 5 Sling Bag
- 6 Small Bags



SAM AMBALAJ
Plastik Nakliyat Hafriyat İnşaat San.ve Tic.Ltd.Şti.

Product Portfolio

Cross Corner – BETO Series







BETO-A	BETO-B	BETO-C
		
BETO-E	BETO-F	BETO-D
		



SAM AMBALAJ
Plastik Nakliyat Hafriyat İnşaat San.ve Tic.Ltd.Şti.

Product Portfolio

Cross Corner – CENTO Series

CENTO-A	CENTO-B	CENTO-C
		
CENTO-E	CENTO-F	CENTO-D
		

Product Portfolio

U Panel – NOVO series

NOVO-A	NOVO-B	NOVO-C
		
NOVO-E	NOVO-F	NOVO-D
		

Product Portfolio

Q Bag – SEDA series

SEDA-A	SEDA-B	SEDA-C
		
SEDA-E	SEDA-F	SEDA-D
		

Product Portfolio

Sling Bag

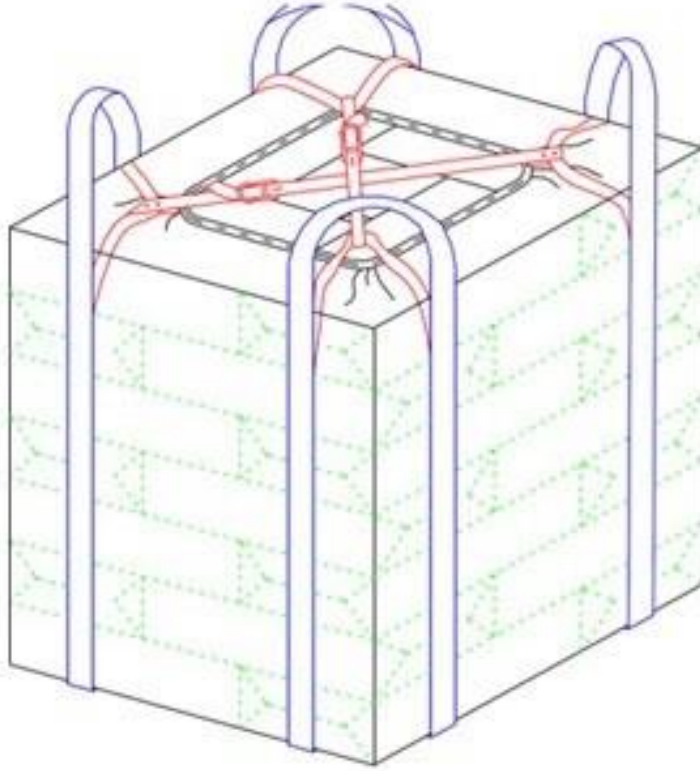

SAM AMBALAJ
Plastik Nakliyat Hafriyat İnşaat San.ve Tic.Ltd.Şti.

Product Portfolio

Discharge Options

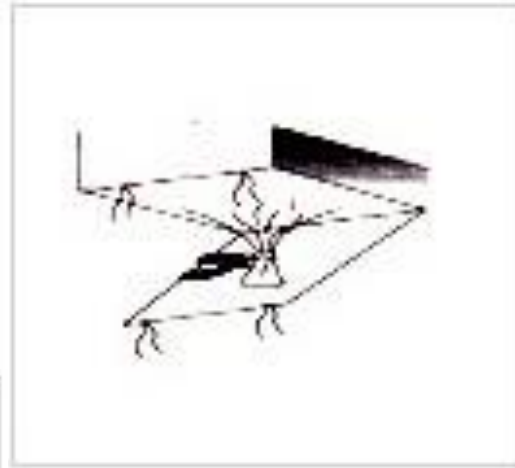
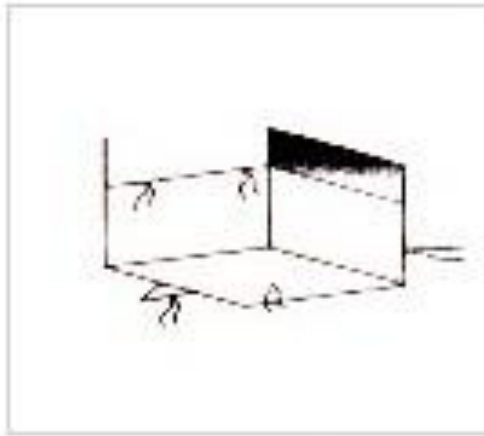

SAM AMBALAJ
Plastik Nakliyat Hafriyat İnşaat San.ve Tic.Ltd.Şti.

Product Portfolio

Discharge Options

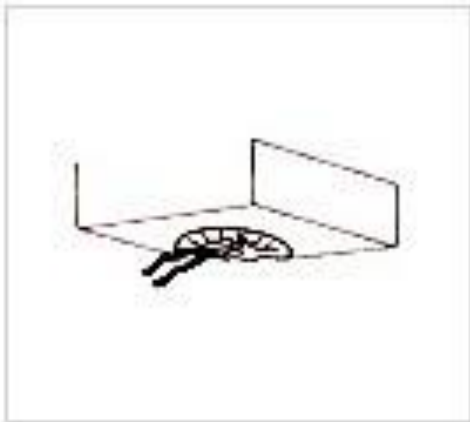
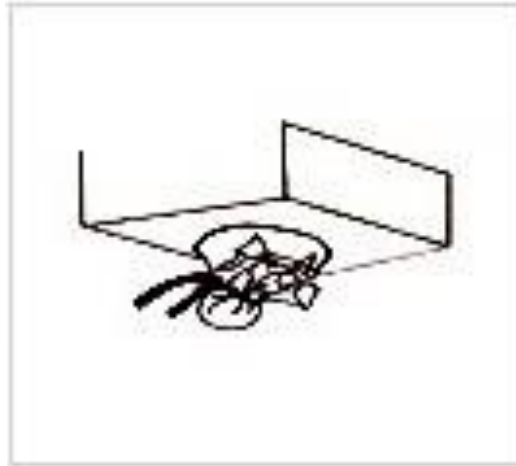
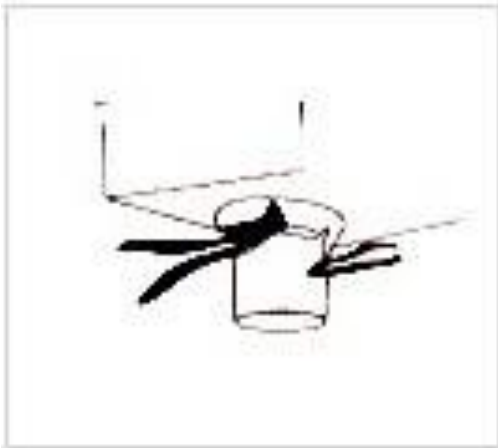

SAM AMBALAJ
Plastik Nakliyat Hafriyat İnşaat San.ve Tic.Ltd.Şti.

Product Portfolio Discharge Options



SAM AMBALAJ
Plastik Nakliyat Hafriyat İnşaat San.ve Tic.Ltd.Şti.

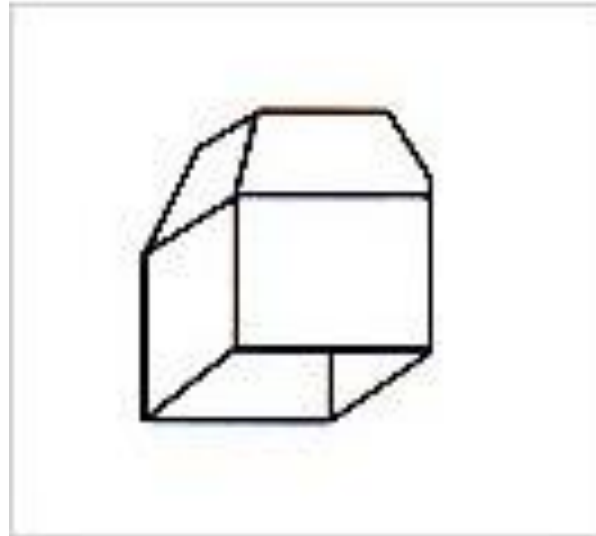
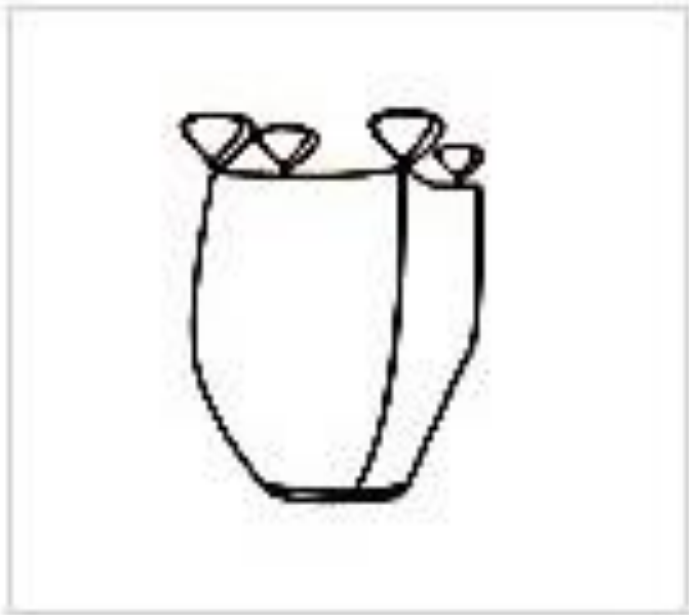

Product Portfolio

Lifting Options

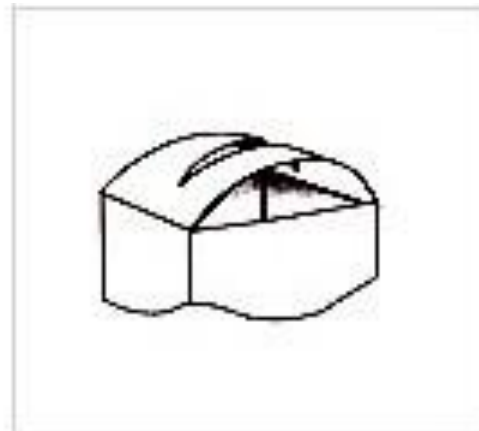



Production

- 1 2 Yarn production lines
- 2 50 weaving machines
- 3 8 Narrow Weaving (Column) Lines
- 4 10 Cutting lines
- 5 3 Printing Lines
- 6 2 lamination lines
- 7 5 sewing workshops
- 8 2 Fully Automated Small Bag Line



SAM AMBALAJ
Plastik Nakliyat Hafriyat İnşaat San.ve Tic.Ltd.Şti.

Yarn Production Line



SAM AMBALAJ has capacity up to 800 tons / month
pp yarn

Weaving Machines



SAM AMBALAJ has 50 weaving machines



Weaving Machines Hall



SAM AMBALAJ
Plastik Nakliyat Hafriyat İnşaat San.ve Tic.Ltd.Şti.

Weaving Lines -





SAM AMBALAJ
Plastik Nakliyat Hafriyat İnşaat San.ve Tic.Ltd.Şti.

Weaving Machines



SAM AMBALAJ has circular fabric weaving lines

Fabrics

SAM AMBALAJ could process wide range of circular & sulzer fabrics





SAM AMBALAJ
Plastik Nakliyat Hafriyat İnşaat San.ve Tic.Ltd.Şti.

Lamination

SAM AMBALAJ could laminate all kind of fabrics inhouse with 2 lines





SAM AMBALAJ
Plastik Nakliyat Hafriyat İnşaat San.ve Tic.Ltd.Şti.

Lamination





SAM AMBALAJ
Plastik Nakliyat Hafriyat İnşaat San.ve Tic.Ltd.Şti.

Column Weaving



SAM AMBALAJ has 5 Column Weaving lines.



SAM AMBALAJ
Plastik Nakliyat Hafriyat İnşaat San.ve Tic.Ltd.Şti.

Small Bag Production



Sam Ambalaj has automated two color printed small bag production machine.



SAM AMBALAJ
Plastik Nakliyat Hafriyat İnşaat San.ve Tic.Ltd.Şti.

Stock Warehouse



Sewing



SAM AMBALAJ
Plastik Nakliyat Hafriyat İnşaat San.ve Tic.Ltd.Şti.





Internal Quality Controls

- 1 Yarn Testing Equipments
- 2 Fabric Testing Equipments
- 3 Sewing Testing
- 4 Final Quality Control
- 5 Food Grade Production Workshop



Certifications

- 1 ISO 9001
- 2 ISO 14001
- 3 OHSAS 18001
- 4 ISO 22000
- 5 ISO 10002
- 6 Food Contact Packaging Production

EFIBCA

Lean



RECYCLE

CERTIFICATIONS



Internal Quality Control Systems



In-House Fabric Testing



Internal Quality Control Systems



In-House Column Testing



SAM AMBALAJ
Plastik Nakliyat Hafriyat İnşaat San.ve Tic.Ltd.Şti.



MAIN REFERENCES



SAM AMBALAJ
Plastik Nakliyat Hafriyat İnşaat San.ve Tic.Ltd.Şti.

CONTACT US



sales@sambigbag.com

International Sales Executive:
Adriana Cazaran



Telefon : 02626414120
Fax : 02626414123



İstasyon Mh. Güney Yan Yol No:82
GEBZE/ KOCAELİ

THANK YOU!



SAM AMBALAJ
Plastik Nakliyat Hafriyat İnşaat San.ve Tic.Ltd.Şti.