

point | HAVALANDIRMA
SİSTEMLERİ



TECHNICAL CATALOGUE



INDEX

	Page 3	About Us
YKF	Page 4	Circular Duct Fan
YKF EC	Page 6	Circular Duct Fan (with EC motor)
KF	Page 8	Rectangular Duct Fan (Internal Motor)
DKF	Page 10	Rectangular Duct Fan (EXT. Motor)
DKF EX	Page 13	Rectangular Duct Fan (Ex-Proof)
KF EC	Page 15	Rectangular Duct Fan (With EC Motor)
CF	Page 17	Horizontal Flow Radial Roof Type Fan (Internal Motor)
CF V	Page 19	Vertical Flow Radial Roof Type Fan (Internal Motor)
DCF V	Page 21	Vertical Flow Radial Roof Type Fan (EXT. Motor)
DCF	Page 23	Horizontal Flow Radial Roof Type Fan (EXT. Motor)
DCF EX	Page 26	Horizontal Flow Radial Roof Type Fan (EXT. Motor - Ex-Proof)
DCF M	Page 28	Horizontal Flow Radial Roof Type Fan (EXT. Motor - Chimney Hood)
CF EC	Page 29	Horizontal Flow Radial Roof Type Fan (Internal Motor, With EC Motor)
ACF	Page 31	Horizontal Flow Axial Roof Type Fan (Internal Motor)
SV	Page 33	Shelter Ventilator (Pocket Type)
SV-W	Page 35	Shelter Ventilator (V-Module)
HSV	Page 37	Shelter Ventilator (Cabinet/Cell Type)
OBSF	Page 39	Low Pressure Centrifugal Blower (Backward Curved Rare Blade)
IGK ECO	Page 41	Heat Recovery Unit (Eco-Single Wall)
IGK	Page 43	Heat Recovery Unit (Plug Fan-Double Wall)
IGK IP	Page 45	Heat Recovery Unit (with Heat Pump)
BF	Page 47	Axial Pressurisation Fan
CAF	Page 51	Roof Type Axial Pressurisation Fan
HAF	Page 55	Axial Pressurisation Fan (Cabinet/Cell Type)
DTF	Page 59	Smoke Extraction Fan
CDTF	Page 63	Smoke Extraction Fan (Roof Type)
HDTF	Page 67	Smoke Extraction Fan (Cabinet/Cell Type)
AF	Page 71	Axial Wall Type Fan
AF EX	Page 73	Axial Wall Type Fan (Ex-Proof)
AJF	Page 75	Axial Jet Fan
RJF SH	Page 76	Radial Jet Fan
SYH	Page 77	Cabinet/Cell Type Aspirator (Dense Blade)
PH	Page 83	Cabinet/Cell Type Aspirator (Rare Blade)
MDF	Page 89	Cabinet/Cell Type Aspirator (Plug Fan)
ESF	Page 95	Kitchen Hood Fan
KS	Page 97	Electrostatic Filter Unit
POOL	Page 98	Air Handling Unit
EI	Page 100	Pool Dehumidification Unit
	Page 101	Electric Heater (In-duct)
FI,HKC,MFS	Page 102	Freq. Inverted Speed Control Device Industrial Ventilator
	Page 103	Certification
	Page 104	Our references





point® | HAVALANDIRMA
SİSTEMLERİ

As Point Ventilation Systems, we have been producing Air Handling Units, Pool Dehumidification Units, various Industrial Fans, Cabinet/Cell Fans etc. since 2012.

The Fans and Ventilation Systems in product range are manufactured in our HYT Group facilities with the Turkish capital, and some minor semifinished parts are supplied from the leading foreign companies in the sector. Our production system has been registered by many domestic and foreign quality systems, especially ISO, CE and TSE.

Undoubtedly, the most important factor is reaching our goals!

We are happy to serve you, our valued customers, with our professional staff, which is one of the most important factor in finding solutions to all the needs of the customers in the Ventilation Industry.

her bir adım önde...

Circular In-duct Fan

YKF



Utilization Areas



Description

- * Low noise level
- * Low energy consumption
- * Galvanised metal sheet body
- * Backward curved radial blades
- * IP44 motor protection
- * ability to work in a humid environment

Technical Drawing

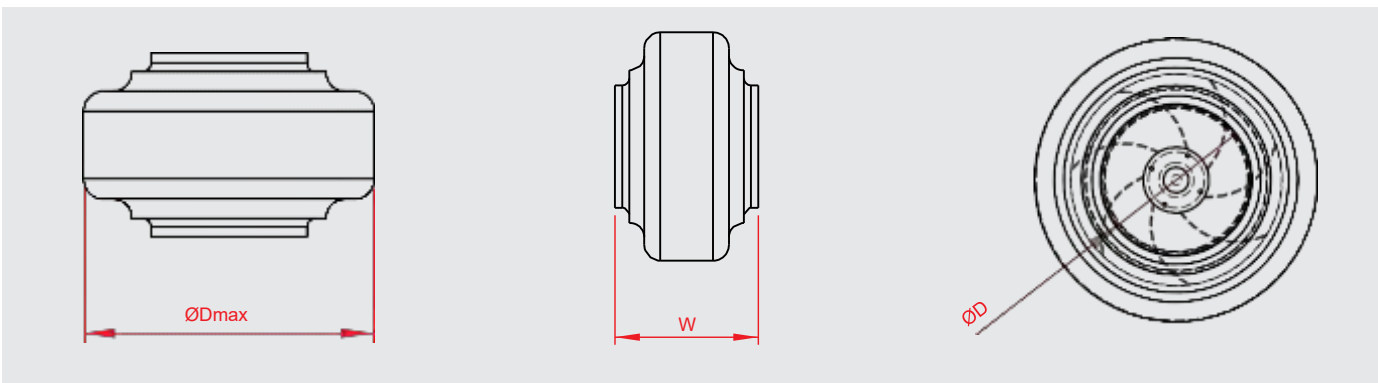

Technical Characteristics

MODELS	FLOW (m³/h)	POWER (W)	VOLTAGE (V)	CURRENT (A)	SPEED (rpm)	FREQ. (Hz)	NOISE (dbA)	DIMENSIONS		
								D (mm)	W (mm)	Dmax (mm)
P-YKF 100	380	67	230	0,35	2300	50	40	98	210	233
P-YKF 125	540	70	230	0,38	2330	50	41	123	203	233
P-YKF 150	650	73	230	0,40	2400	50	44	149	230	322
P-YKF 200 A	780	95	230	0,57	1400	50	46	199	228	342
P-YKF 200 B	1000	103	230	0,66	2600	50	49	199	228	342
P-YKF 250 A	1100	145	230	0,71	2500	50	49	248	227	342
P-YKF 250 B	1200	165	230	0,85	2700	50	54	248	227	342
P-YKF 315 A	1550	180	230	1,2	2400	50	52	311	220	397
P-YKF 315 B	1900	195	230	1,3	2500	50	56	311	220	397

Performance

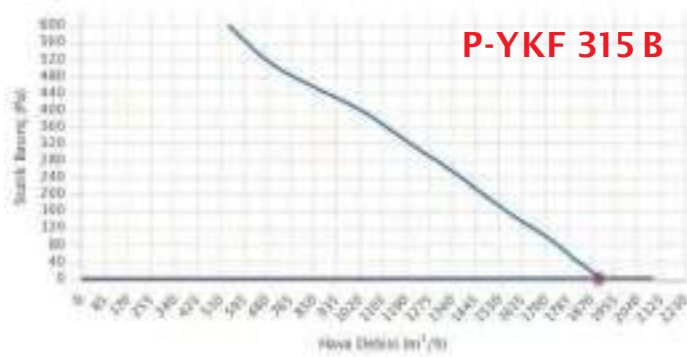
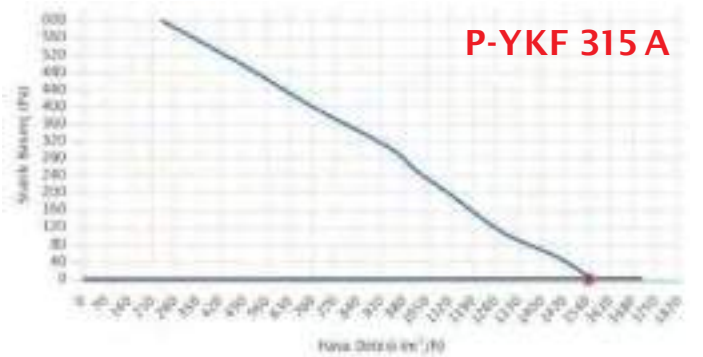
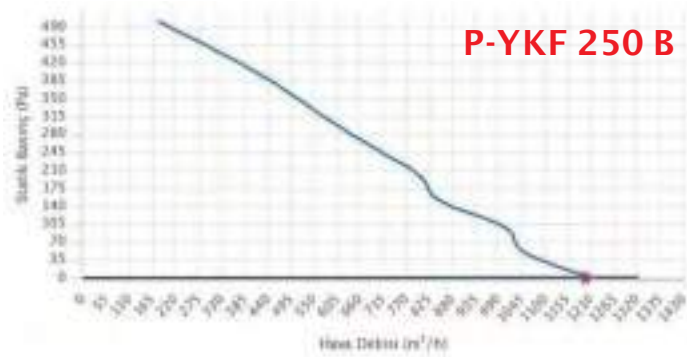
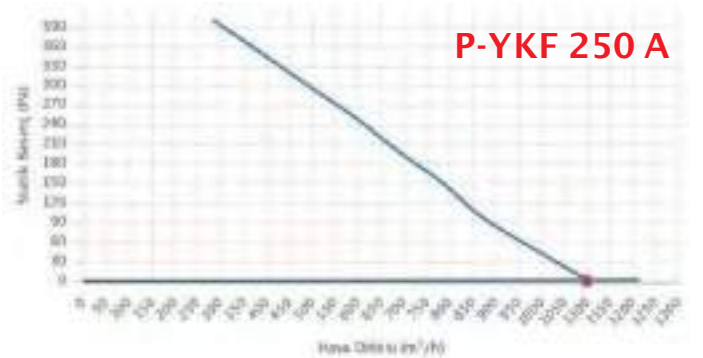
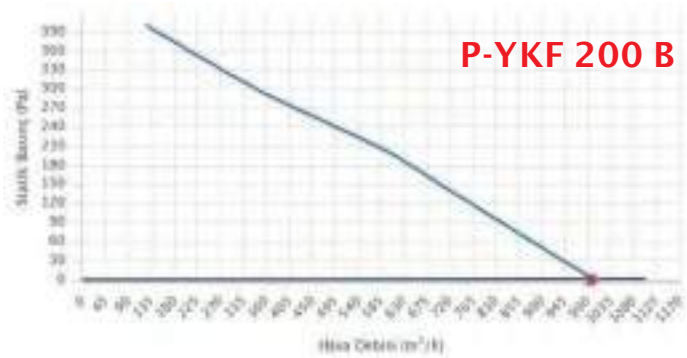
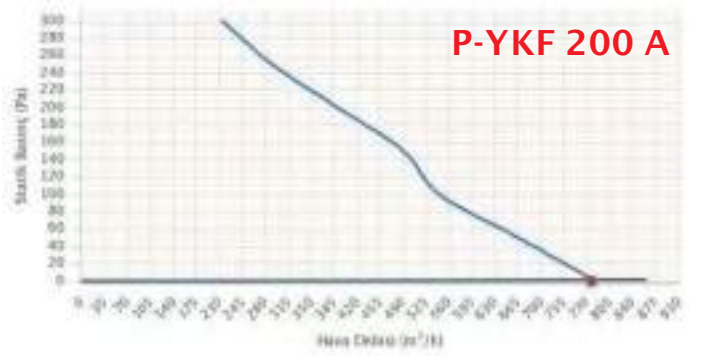
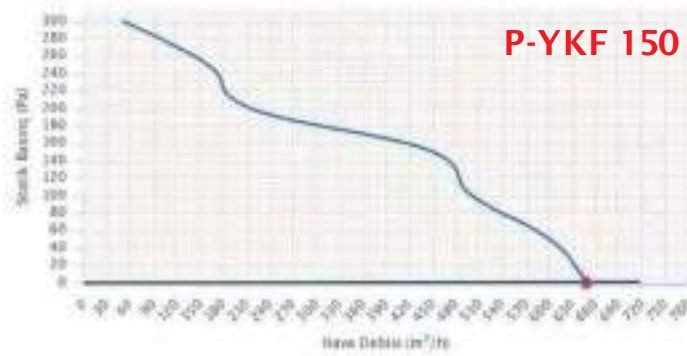
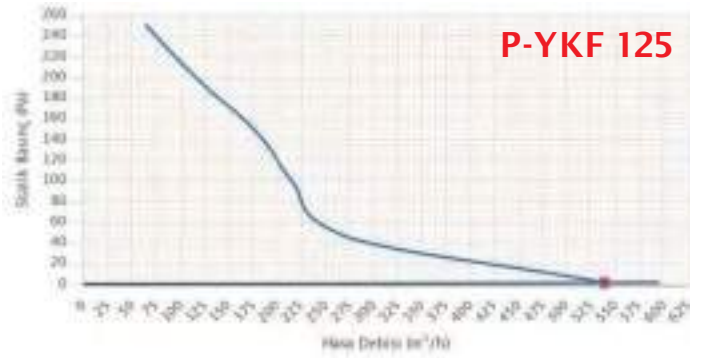
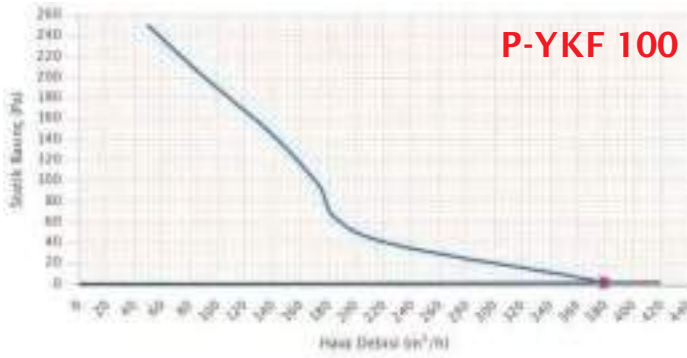

Circular (With EC Motor) In-duct Fan

YKF-EC



point®



Utilization Areas



Description

- * Backward curved radial blades
- * Low energy consumption
- * Low noise level
- * Easy installation ve Montaj
- * High Efficiency
- * Galvanised Sheet Metal

Technical Drawing

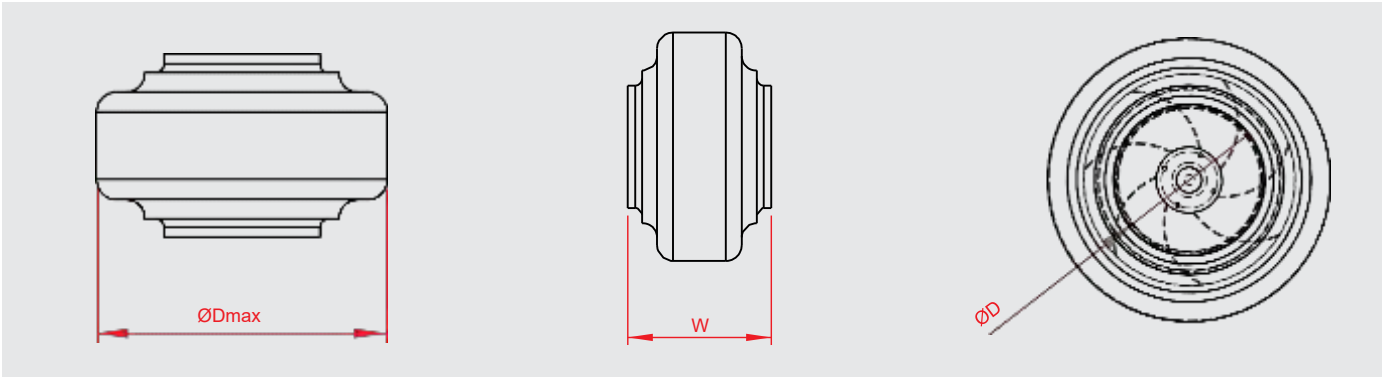

Technical Characteristics

MODELS	FLOW (m³/h)	POWER (W)	VOLTAGE (V)	CURRENT (A)	SPEED (rpm)	FREQ. (Hz)	NOISE (dbA)	D (mm)	DIMENSIONS W (mm)	Dmax (mm)
P-YKF 100-EC	345	0,09	230	0,7	3600	50	44	98	203	255
P-YKF 125-EC	480	0,08	230	0,58	3400	50	45	123	203	255
P-YKF 150-EC	700	0,10	230	0,89	3060	50	48	149	240	305
P-YKF 200-EC	845	0,08	230	0,63	2500	50	47	198	245	345
P-YKF 250-EC	1230	0,16	230	1,15	2900	50	46	248	250	345
P-YKF 315-EC	1370	0,16	230	1,15	2900	50	48	314	260	405

EC Motorlar HVAC sistemlerinde en High Efficiencyyi gösterirler , bu da %90'a varan oranlarda demektir. Özellikle kısmi yük aralığında, klasik AC sürücü konseptlerine kıyasla %50'ye varan toplam enerji tasarrufu sağlar. Özellikle elektronik sürücülerin çok sık olarak kısmi yük işletiminde kullanıldığı HVAC uygulamalarında bu son derece önemlidir. Özel darbe deseni, değişken FREQ.lı sürücülere (VFD) kıyasla gürültünün azaltılmasına yardımcı olur.

Performance Curves

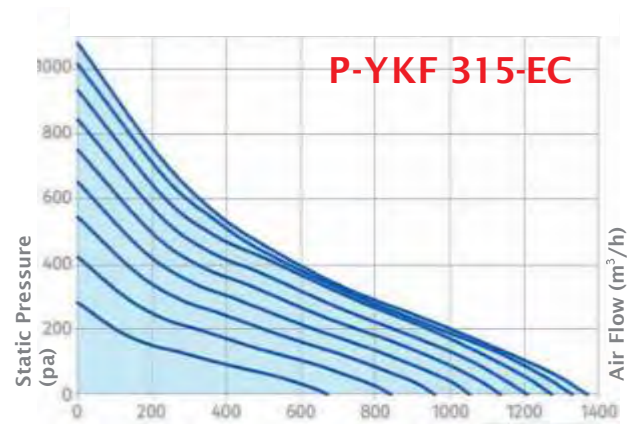
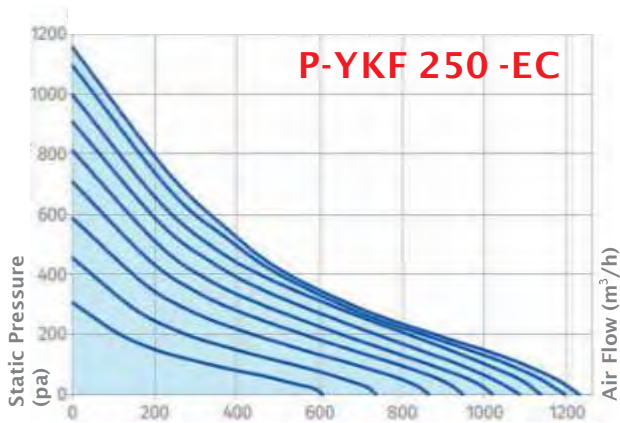
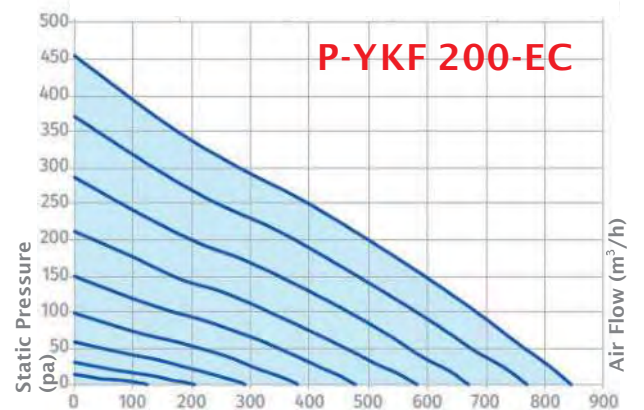
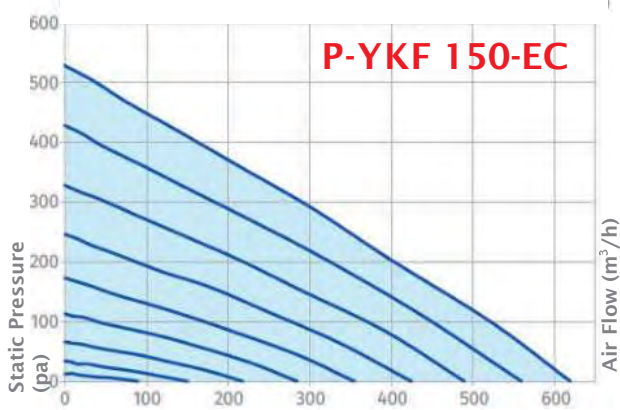
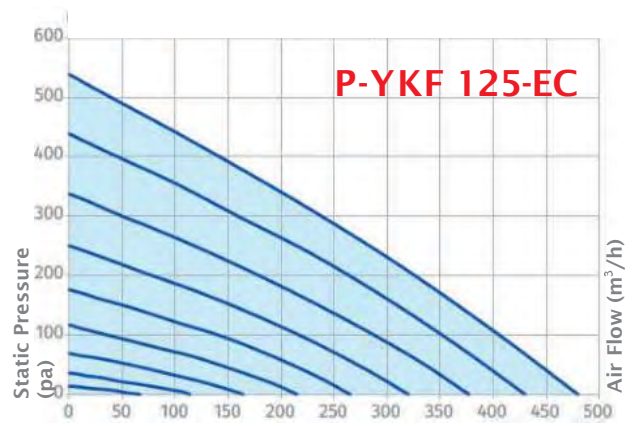
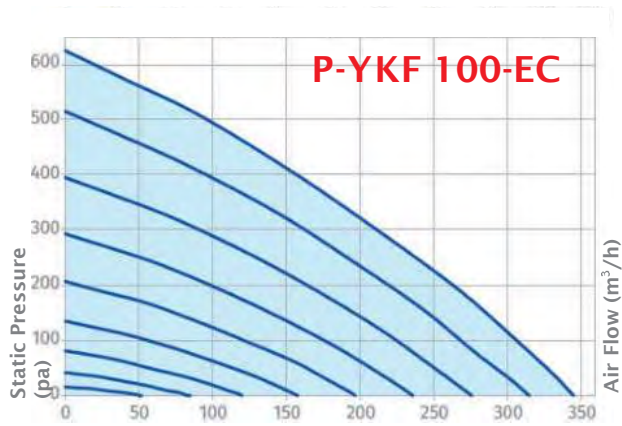

EC Motor Diagram

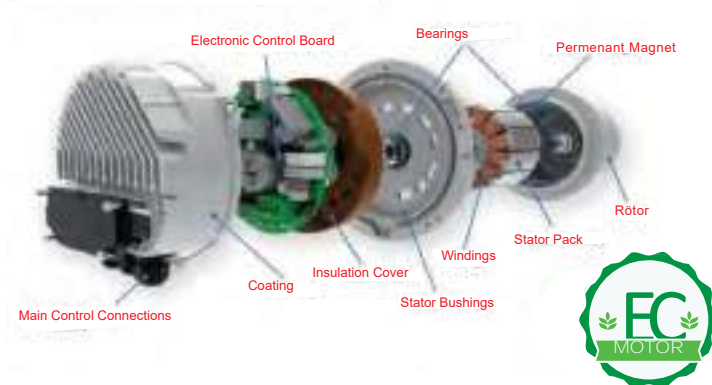

Rectangular (Internal Motor) In-duct Fan

KF



Utilization Areas



Description

- * Low energy consumption
- * Low noise level
- * IP44 motor protection
- * Galvanised metal sheet body
- * Yüksek basınç
- * Azaltılmış türbülans

Technical Drawing

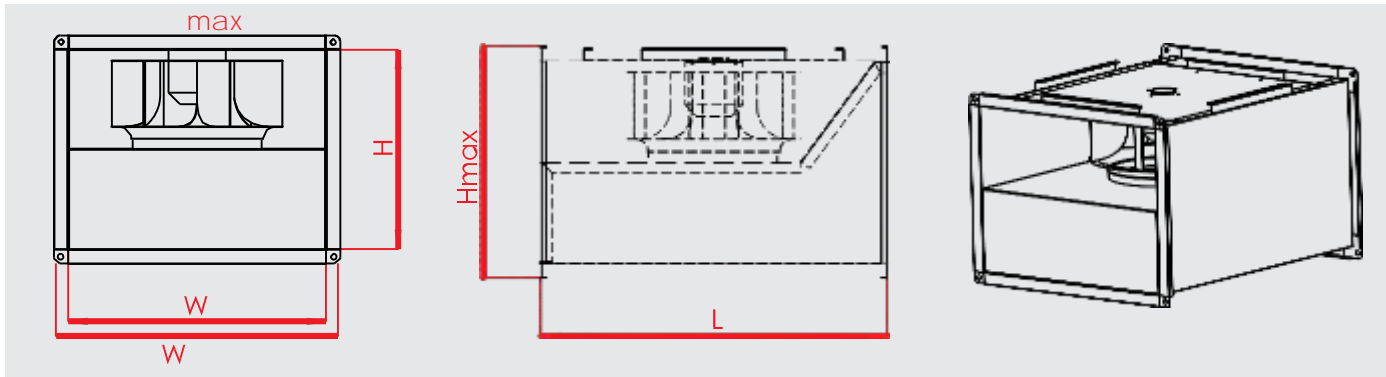

Technical Characteristics

MODELS	FLOW (m³/h)	POWER (kW)	VOLTAGE (V)	CURRENT (A)	SPEED (rpm)	FREQ. (Hz)	NOISE (dbA)	W (mm)	Wmax (mm)	DİMENSİ ONS H (mm)	Hmax (mm)	L (mm)
P-KF 30-15	470	0.09	230	0.42	2600	50	45	300	350	150	200	405
P-KF 40-20 A	960	0.16	230	0.68	2600	50	52	400	450	200	250	505
P-KF 40-20 B	1160	0.18	230	0.80	2700	50	56	400	450	200	250	505
P-KF 50-25	1620	0.18	230	0.80	2700	50	54	500	550	250	300	565
P-KF 60-30	1860	0.29	230	1.50	2500	50	50	600	650	300	350	755
P-KF 60-35 A	2750	0.21	230	1	1400	50	54	600	650	350	400	755
P-KF 60-35 B	3350	0.26	230	1.20	1350	50	58	600	650	350	400	755
P-KF 70-40 A	4400	0.43	230	1.50	1380	50	58	700	750	400	450	805
P-KF 70-40 B	5850	0.80	230	3.50	1350	50	60	700	750	400	450	805
P-KF 80-50	7540	1.10	230	2.50	1400	50	64	800	850	500	550	925
P-KF 100-50	9650	1.50	230	2.60	1400	50	66	1000	1050	500	550	1060

Performance Curves

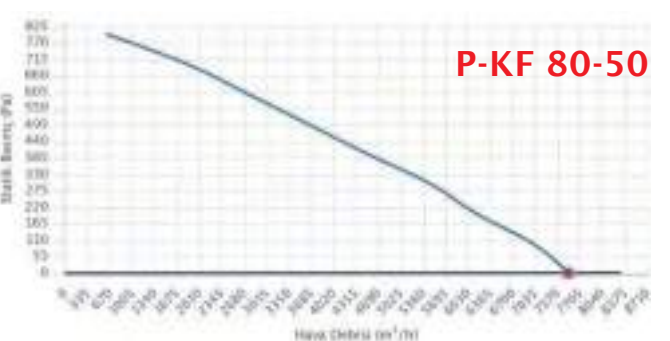
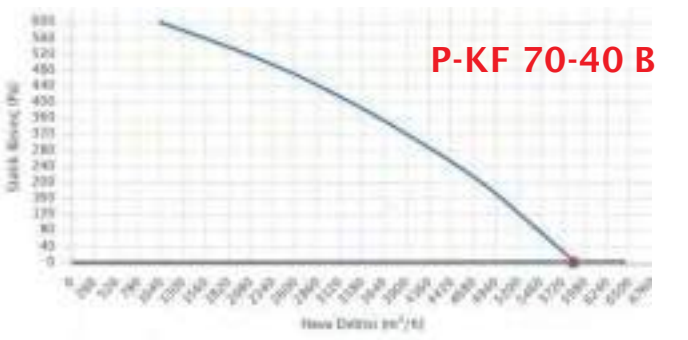
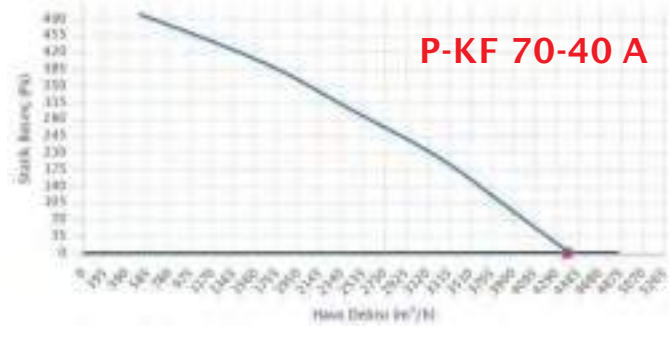
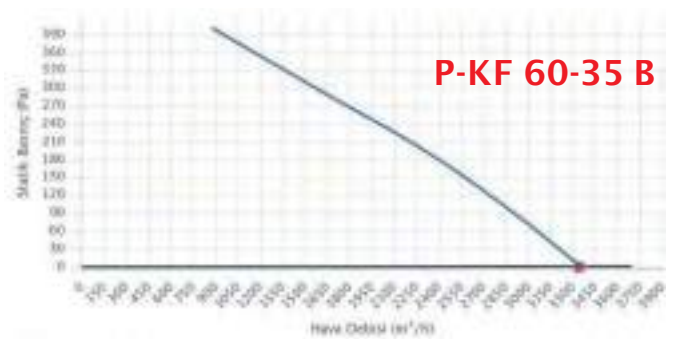
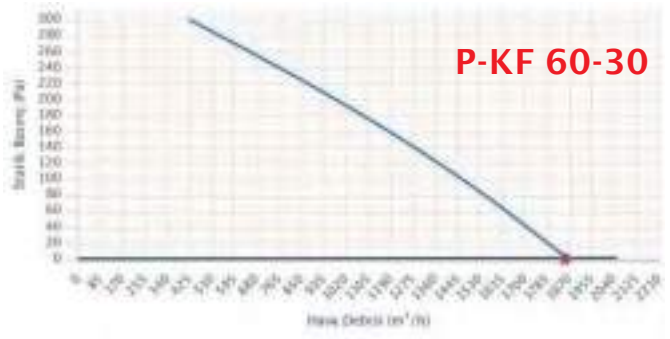
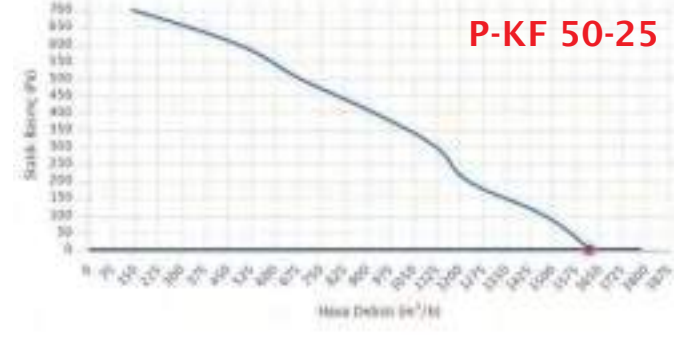
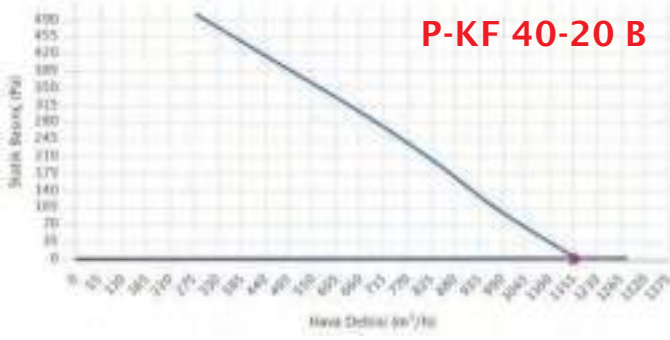
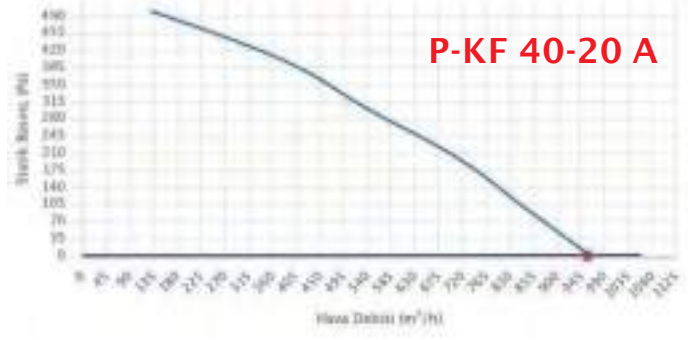
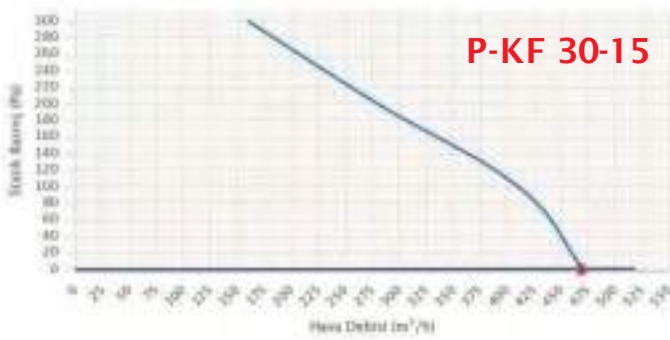

Rectangular (EXT. Motor) In-duct Fan

DKF



Utilization Areas



Description

- * EXT. motor
- * Ip55 protection class
- * Access Door
- * Self-flanged structure
- * Low energy consumption
- * Low noise level
- * Galvanised Steel Sheet
- * Easy Installation

Technical Drawing

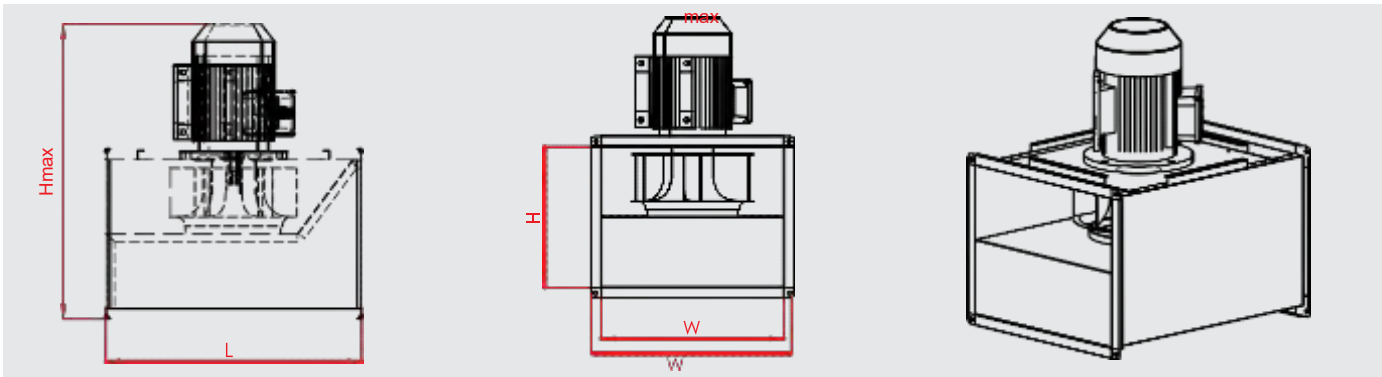

Technical Characteristics

MODELS	FLOW (m³/h)	POWER (kW)	VOLTAGE (V)	CURRENT (A)	SPEED (rpm)	FREQ. (Hz)	NOISE (dB(A))	W (mm)	DIMENSIO NS		Hmax (mm)	L (mm)
									Wmax (mm)	H (mm)		
P-DKF 315 M	2200	0.25	230	2	1500	50	70	600	650	350	570	755
P-DKF 355 M	3100	0.25	230	2	1500	50	75	600	650	350	570	755
P-DKF 400 M	4200	0.37	230	3.20	1500	50	79	700	750	400	650	805
P-DKF 450 M	5500	0.55	230	4.20	1500	50	82	700	750	400	650	805
P-DKF 500 M	8100	1.1	230	7.10	1500	50	85	800	850	500	800	925
P-DKF 560 M	10500	2.2	230	13.40	1500	50	90	1000	1050	500	800	1060
P-DKF 315 T	2200	0.25	380	0.80	1500	50	97	600	650	350	570	755
P-DKF 355 T	3100	0.25	380	0.80	1500	50	97	600	650	350	570	755
P-DKF 400 T	4200	0.37	380	1.15	1500	50	97	700	750	400	650	805
P-DKF 450 T	5500	0.55	380	1.60	1500	50	97	700	750	400	650	805
P-DKF 500 T	8100	1.10	380	2.60	1500	50	97	800	850	500	800	925
P-DKF 560 T	10500	2.2	380	5	1500	50	97	1000	1050	500	800	1060

Performance Curves

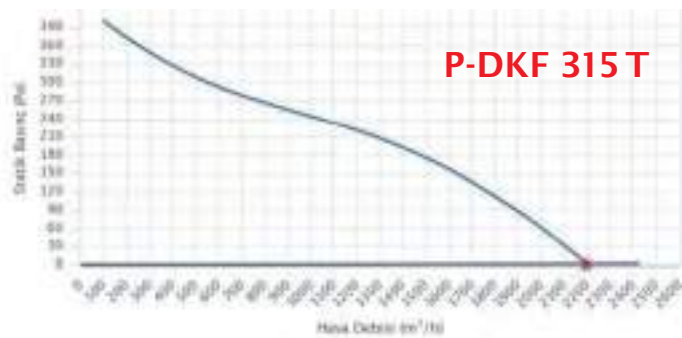
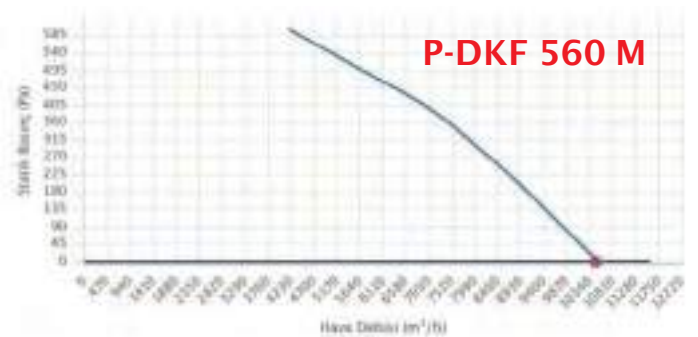
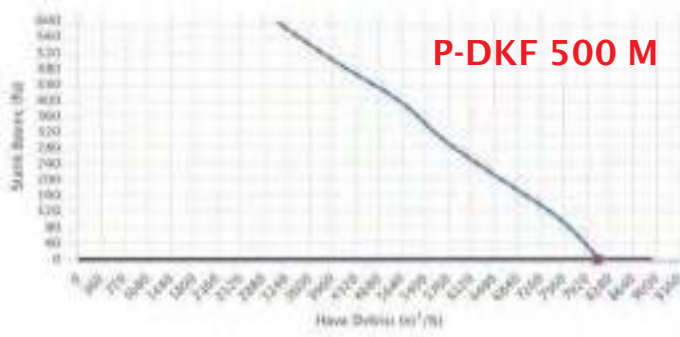
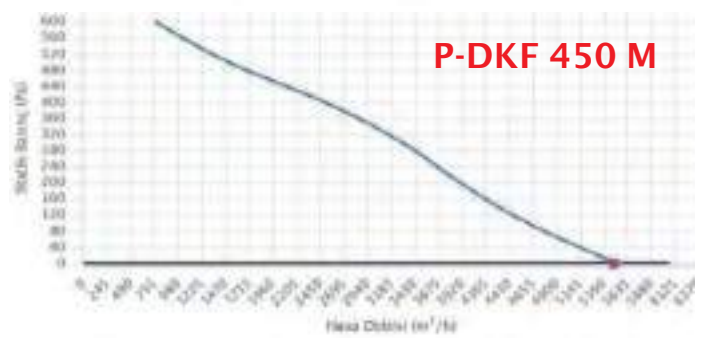
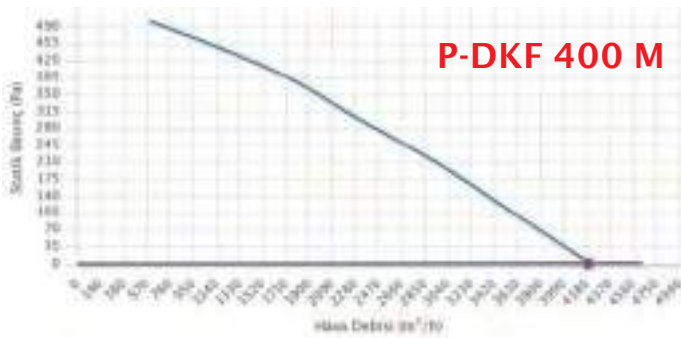
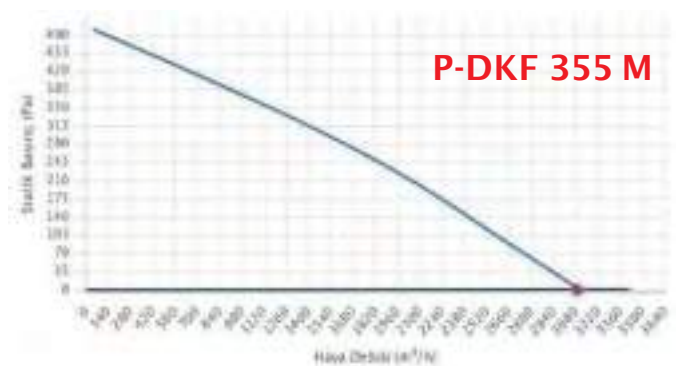
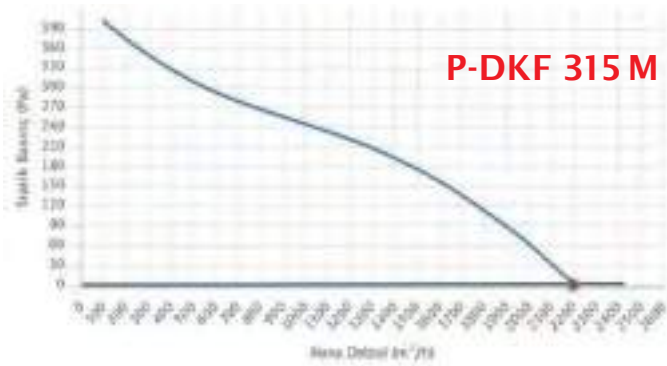

Performance Curves

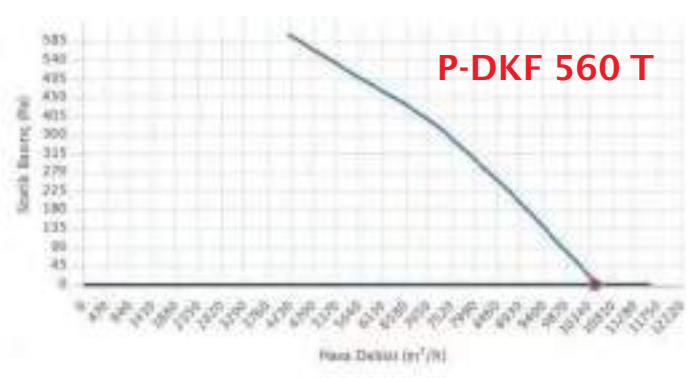
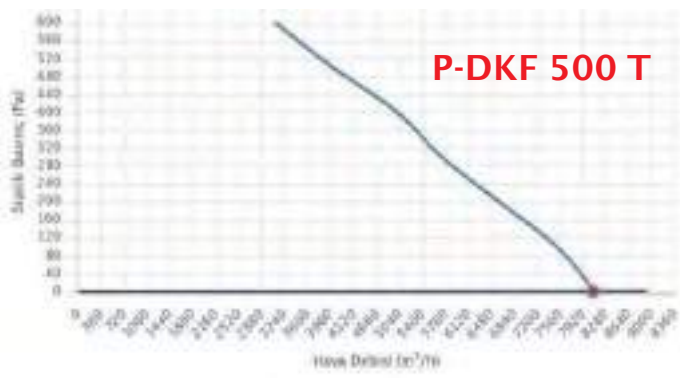

Rectengular (EXT. Motor, Ex-Proof) In-duct Fan

DKF-EX



Utilization Areas



Description

- * EXT. motor
- * Exproof motor
- * Access Door
- * Self-flanged structure
- * Low energy consumption
- * Low noise level
- * Galvanised Steel Sheet
- * Easy Installation

Technical Drawing

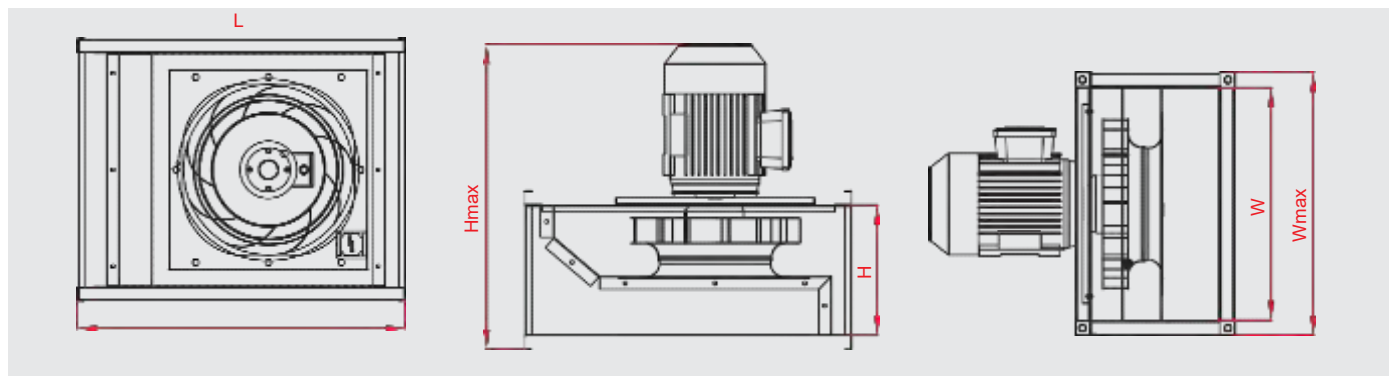

Technical Characteristics

MODELS	FLOW (m³/h)	POWER (kW)	VOLTAGE (V)	CURRENT (A)	SPEED (rpm)	FREQ. (Hz)	NOISE (dbA)	W (mm)	DIMENSIO NS		Hmax (mm)	L (mm)
									Wmax (mm)	H (mm)		
P-DKF EX 315	2200	0.25	380	0.8	1500	50	70	600	650	350	630	755
P-DKF EX 355	3100	0.25	380	0.8	1500	50	75	600	650	350	630	755
P-DKF EX 400	4200	0.37	380	1.15	1500	50	79	700	750	400	680	805
P-DKF EX 450	5500	0.55	380	1.60	1500	50	82	700	750	400	680	805
P-DKF EX 500	8100	1.1	380	2.70	1500	50	85	800	850	500	840	925
P-DKF EX 560	10500	2.2	380	3.60	1500	50	85	1000	1050	500	870	1060



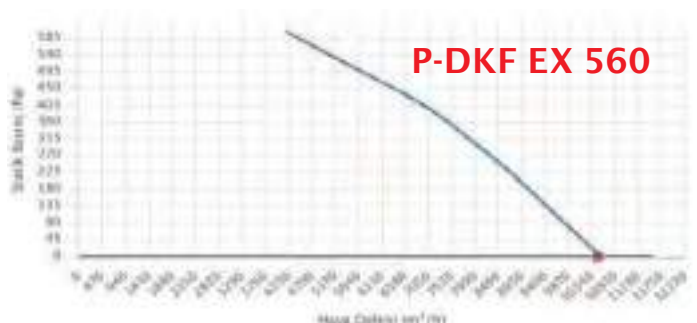
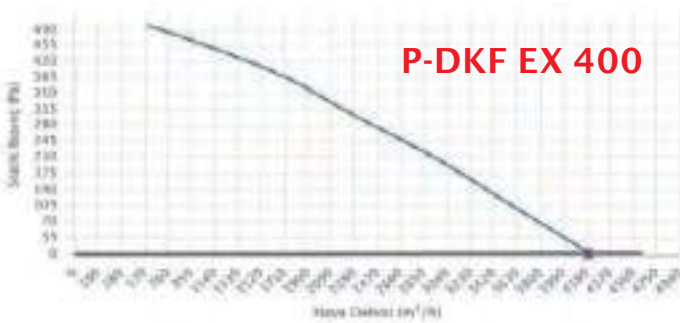
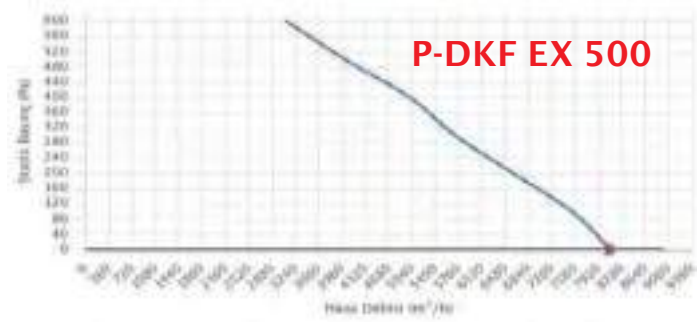
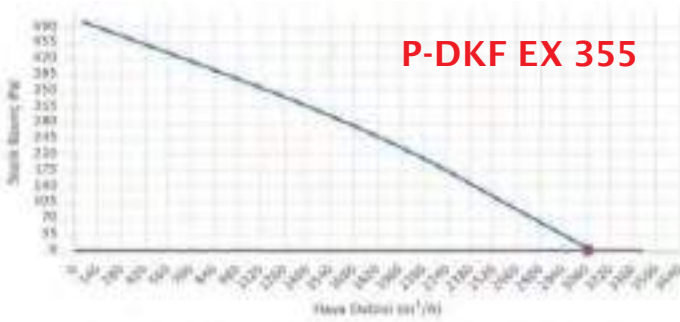
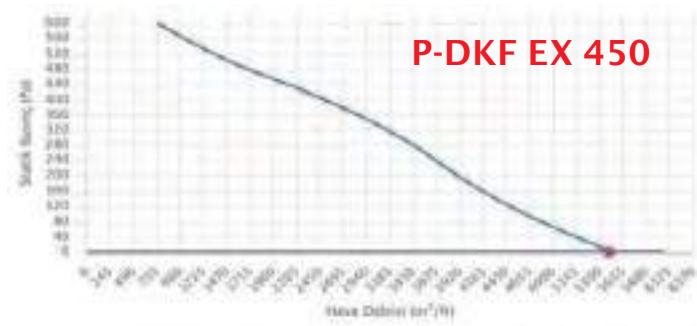
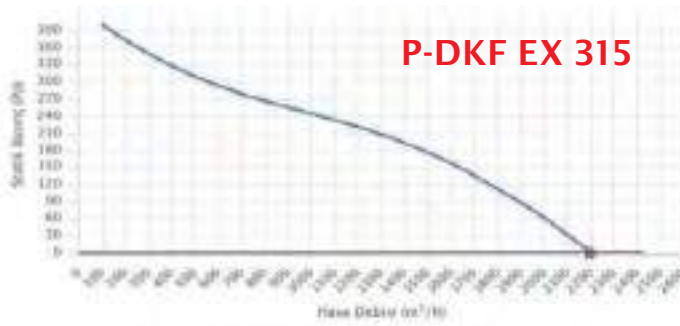

WHAT IS ATEX

ATEX, which comes from the French term “Atmosphères Explosibles”; It stands for Explosive Atmospheres. The necessary technical and legal conditions for the safe operation of equipment and protection systems intended to be used in potentially explosive atmospheres have been determined by the European Parliament and the Council with the New Approach directive No. 94/9/EC.

WHAT IS ATEX CERTIFICATE

It is an international certificate taken for products used in explosive, flammable and easily flammable environments and for the place of production.

IS ATEX CERTIFICATE MANDATORY?

Based on the Law on the Preparation and Implementation of the Technical Legislation on Products, dated 29.06.2001 and numbered 4703, the European Union directive numbered 94/9/EC, shortly called the ATEX directive, entered into force by being published in the Official Gazette dated 30.12.2006 and numbered 26392.

Rectengular (Internal EC Motor) In-duct Fan

KF-EC



Utilization Areas



Description

- * Backward Curved Radial Blades
- * Low energy consumption
- * Low Turbulance
- * Low noise level
- * High Pressure
- * Smaller Motor for the same efficiency.

Technical Drawing

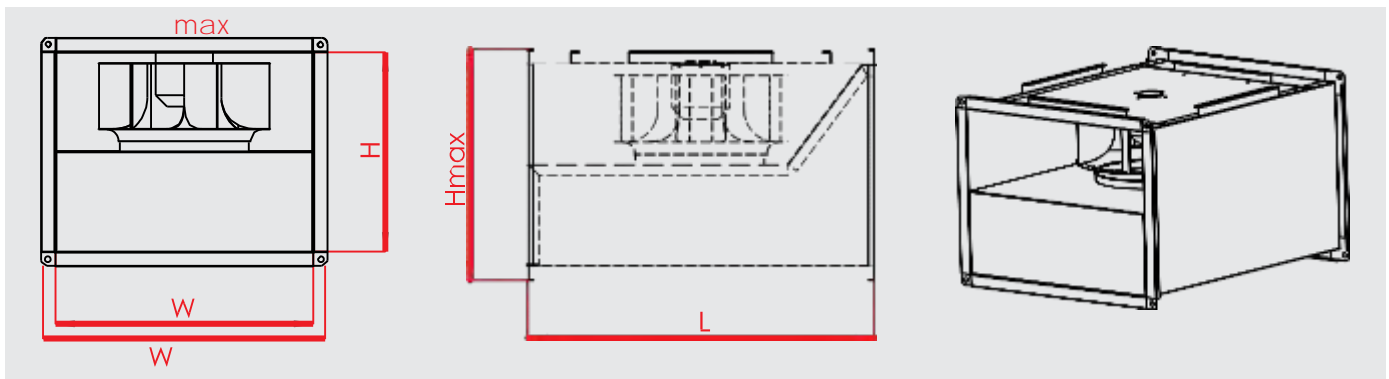

Technical Characteristics

MODELS	FLOW (m³/h)	POWER (W)	VOLTAGE (V)	CURRENT (A)	SPEED (rpm)	FREQ. (Hz)	NOISE (dbA)	W (mm)	DIMENSIONS		Hmax (mm)	L (mm)
									Wmax (mm)	H (mm)		
P-KF-EC 30-15	565	97	230	0,73	3300	50	44	300	350	150	200	405
P-KF-EC 40-20 A	810	91	230	0,69	2470	50	43	400	450	200	250	505
P-KF-EC 40-20 B	1190	192	230	1,43	3010	50	47	400	450	200	250	505
P-KF-EC 50-25	1590	252	230	1,85	2500	50	45	500	550	250	300	565
P-KF-EC 60-30	2545	326	230	2,45	2000	50	48	600	650	300	350	755
P-KF-EC 60-35 A	2815	361	230	2,62	2000	50	49	600	650	350	400	755
P-KF-EC 60-35 B	4290	1308	230	2,35	3160	50	55	600	650	350	400	755
P-KF-EC 70-40 A	5710	795	230	3,48	1400	50	53	700	750	400	450	805
P-KF-EC 70-40 B	6810	2748	230	2,80	2530	50	57	700	750	400	450	805
P-KF-EC 80-50	8395	2025	380	2,01	1470	50	60	800	850	500	550	925
P-KF-EC 100-50	11190	3429	380	5,00	1800	50	66	1000	1050	500	550	1060

Performance Curves

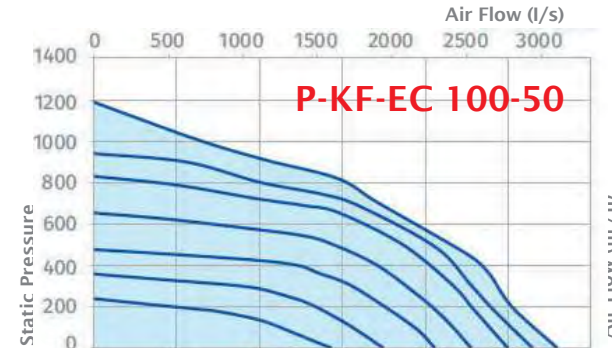
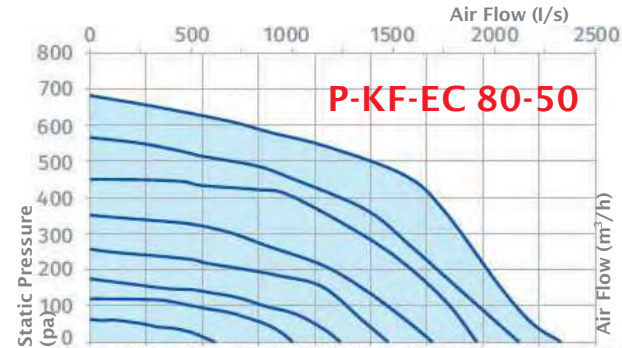
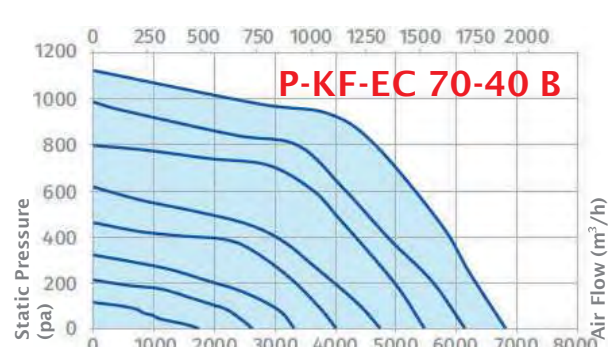
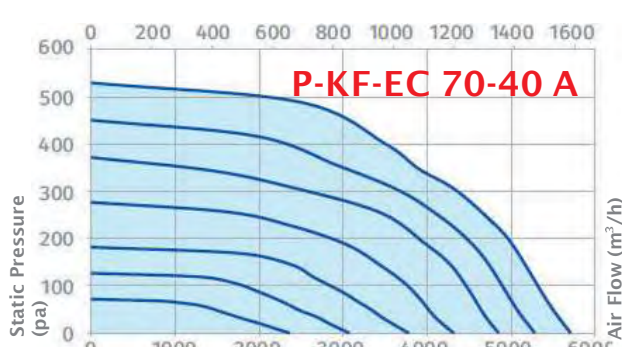
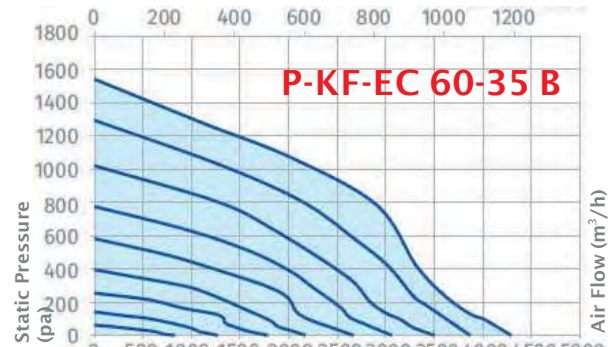
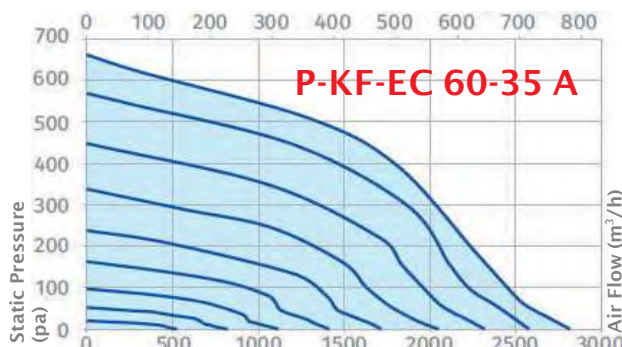
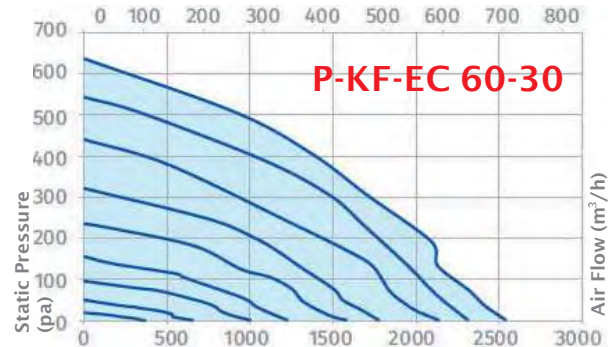
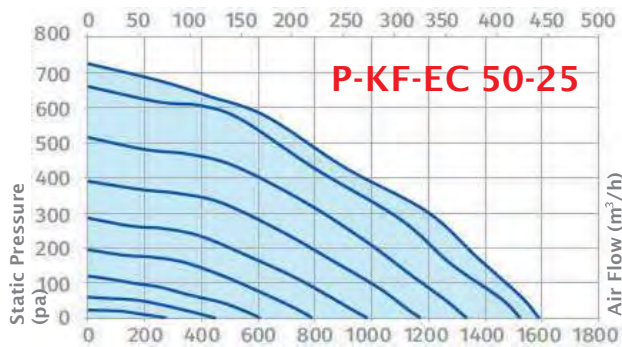
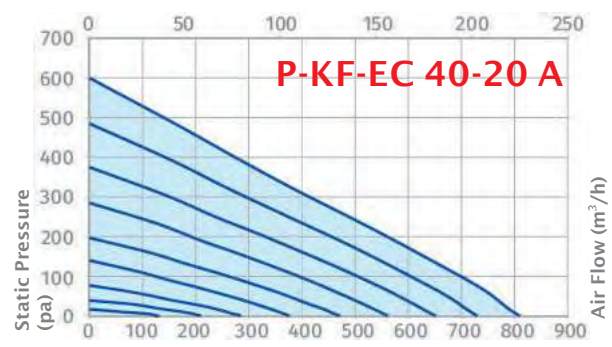
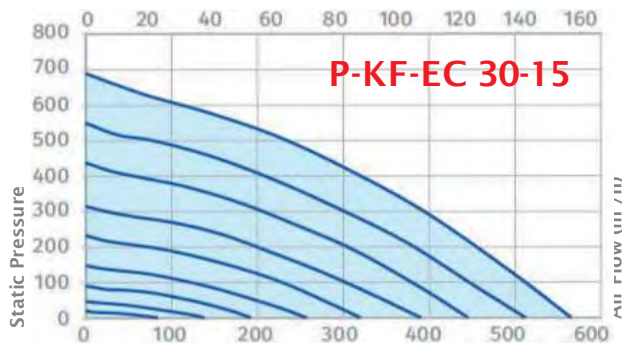

Horizontal Flow (Internal Motor) Radial Roof Type Fan

CF



Utilization Areas



Description

- * Low energy consumption
- * Low noise level
- * IP44 motor protection
- * Termik korumalı
- * Backward curved radial blades
- * Galvanised metal sheet body

Technical Drawing

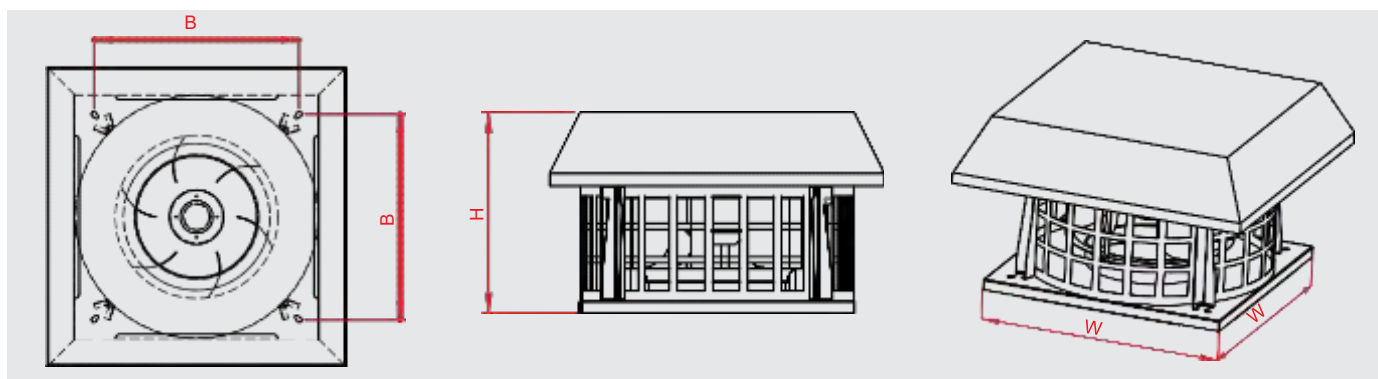

Technical Characteristics

MODELS	FLOW (m ³ /h)	POWER (W)	VOLTAGE (V)	CURRENT (A)	SPEED (rpm)	FREQ. (Hz)	NOISE (dbA)	B (mm)	DIMENSIONS W (mm)	H (mm)
P-CF 180	480	0.09	230	0.42	2600	50	48	203	250	180
P-CF 225	910	0.16	230	0.68	2600	50	49	270	340	235
P-CF 250	1250	0.18	230	0.80	2700	50	51	305	370	235
P-CF 280	2000	0.29	230	1.50	2500	50	46	330	452	235
P-CF 355	2930	0.21	230	1.00	1400	50	45	370	445	330
P-CF 400	4120	0.26	230	1.20	1350	50	50	420	490	370
P-CF 450	5350	0.80	230	3.50	1350	50	51	460	540	440
P-CF 500	7650	1.50	380	2.60	1400	50	55	490	590	490
P-CF 560	9890	2.50	380	4.50	1340	50	65	540	640	550

Performance Curves

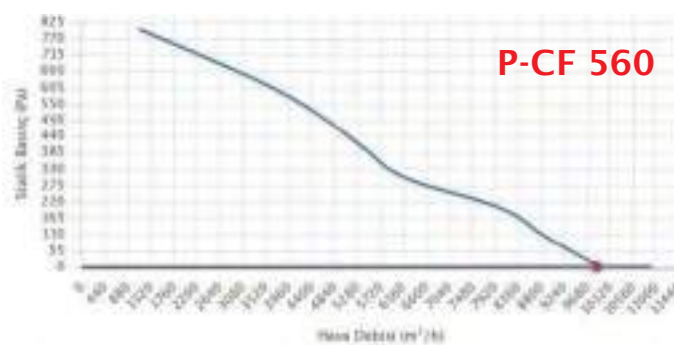
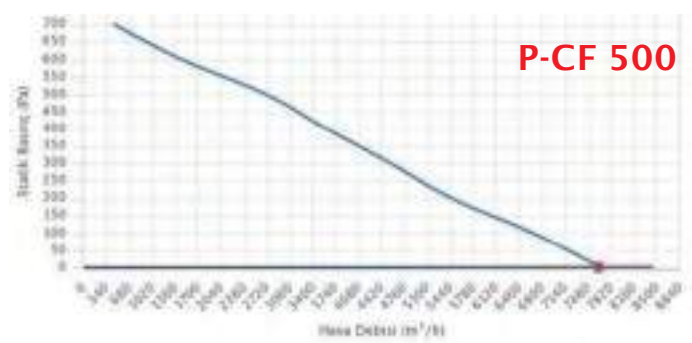
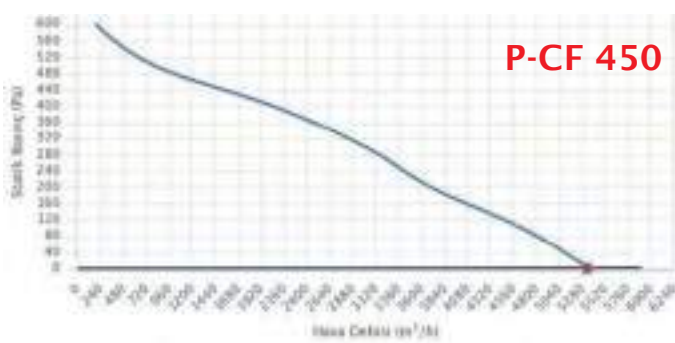
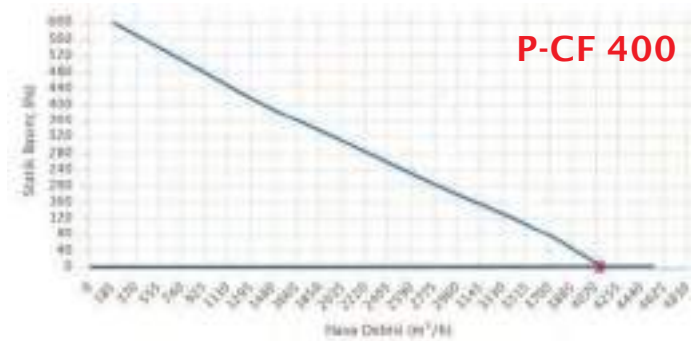
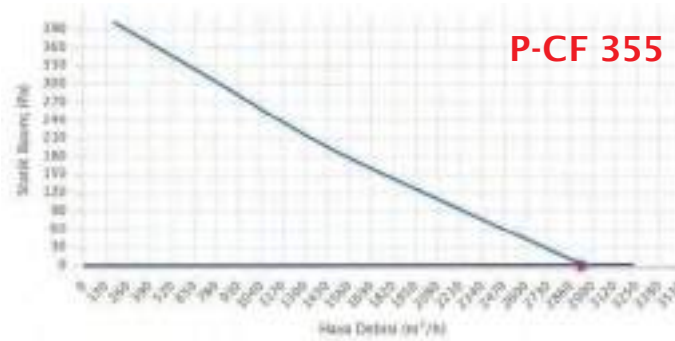
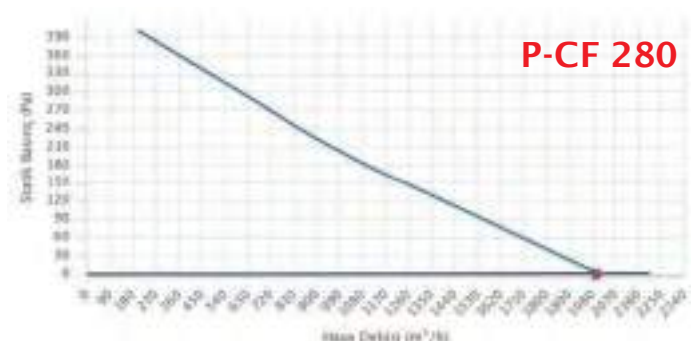
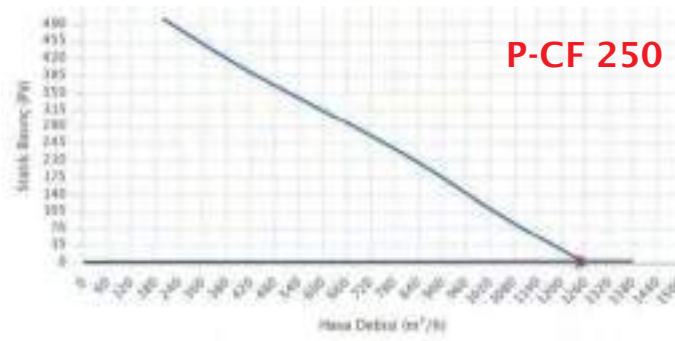
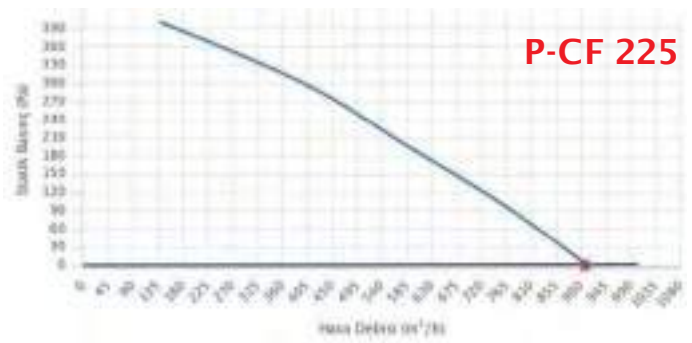
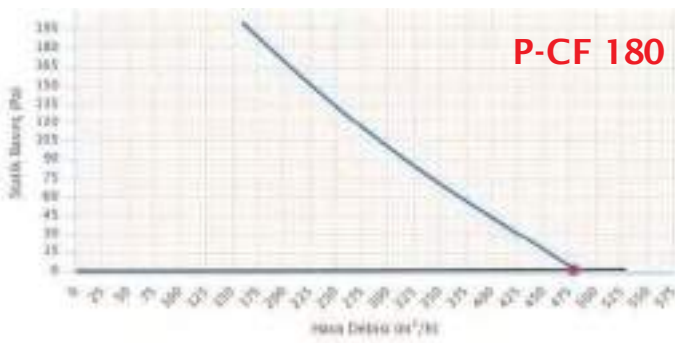

Vertical Flow (Internal Motor) Radial Roof Type Fan

CF-V



point®



Utilization Areas



Description

- * Backed Curved Radial Blades
- * Low noise level
- * IP44 Motor Protection
- * Galvanised metal sheet body
- * Thermic Protection
- * Easy installation

Technical Drawing

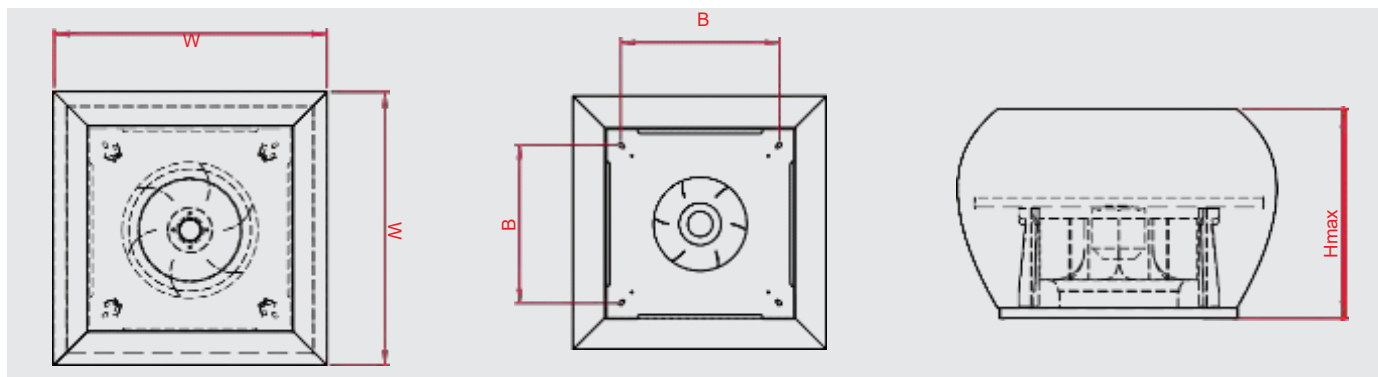

Technical Characteristics

MODELS	FLOW (m³/h)	POWER (kW)	VOLTAGE (V)	CURRENT (A)	SPEED (rpm)	FREQ. (Hz)	NOISE (dbA)	B (mm)	DIMENSIONS W (mm)	Hmax (mm)
P-CF V 225	910	0,09	230	0,59	2750	50	49	400	450	280
P-CF V 280	2000	0,15	230	0,85	1400	50	46	500	550	280
P-CF V 355	2930	0,22	230	1,16	1400	50	45	530	590	280
P-CF V 400	4120	0,33	230	1,63	1400	50	50	580	640	280
P-CF V 450	5350	0,45	230	2,16	1400	50	51	630	690	340
P-CF V 500	7650	0,86	230	2,46	1400	50	55	680	740	340
P-CF V 560	9890	1,48	230	4,09	1400	50	65	730	790	340

Performance Curves

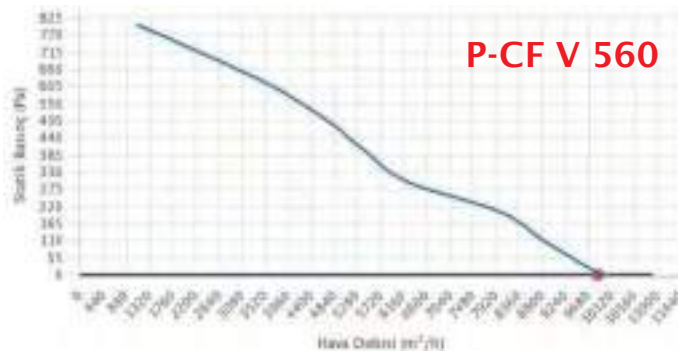
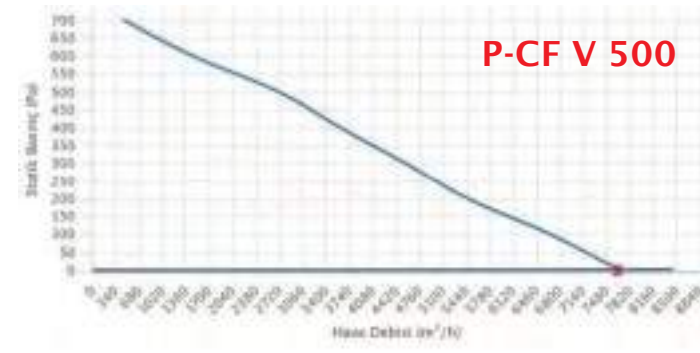
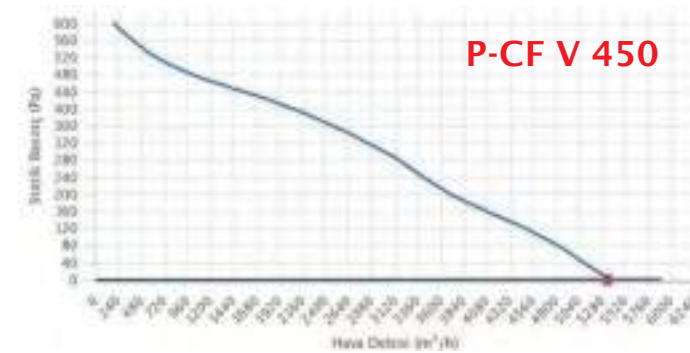
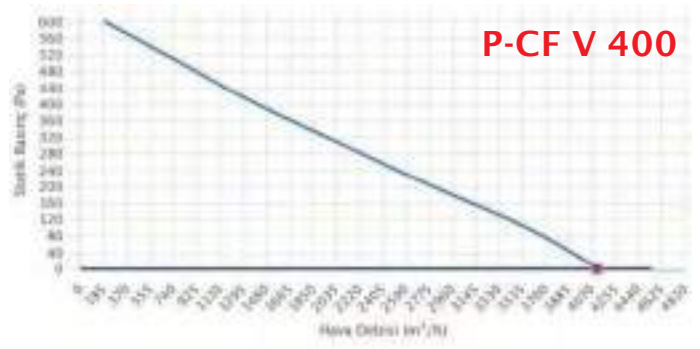
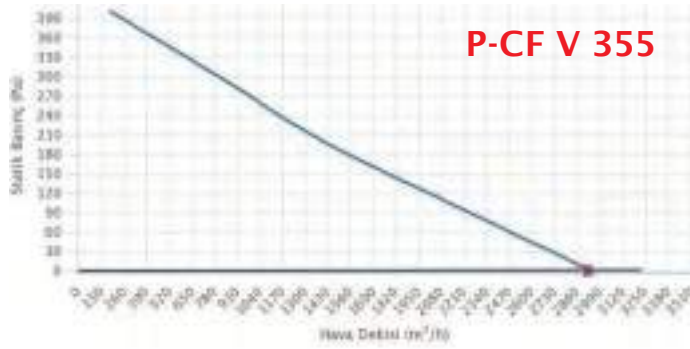
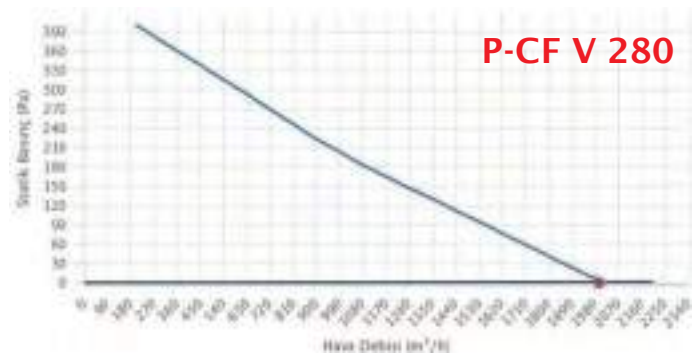
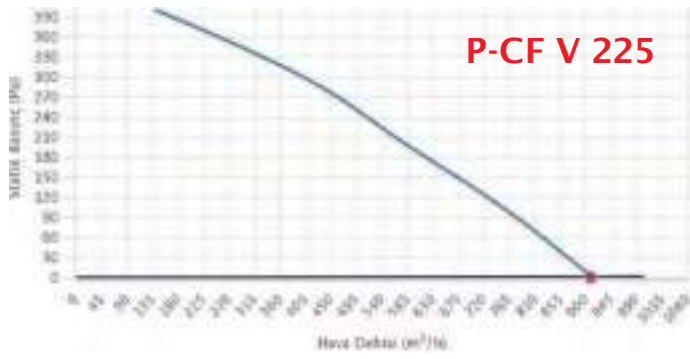

Vertical Flow (EXT. Motor) Radial Roof Type Fan

DCF-V



Utilization Areas



Description

- * Backed Curved Radial Blades
- * Galvanised metal sheet body
- * Low Noise Level
- * Thermic Protection
- * IP55 Motor protection
- * Easy installation

Technical Drawing

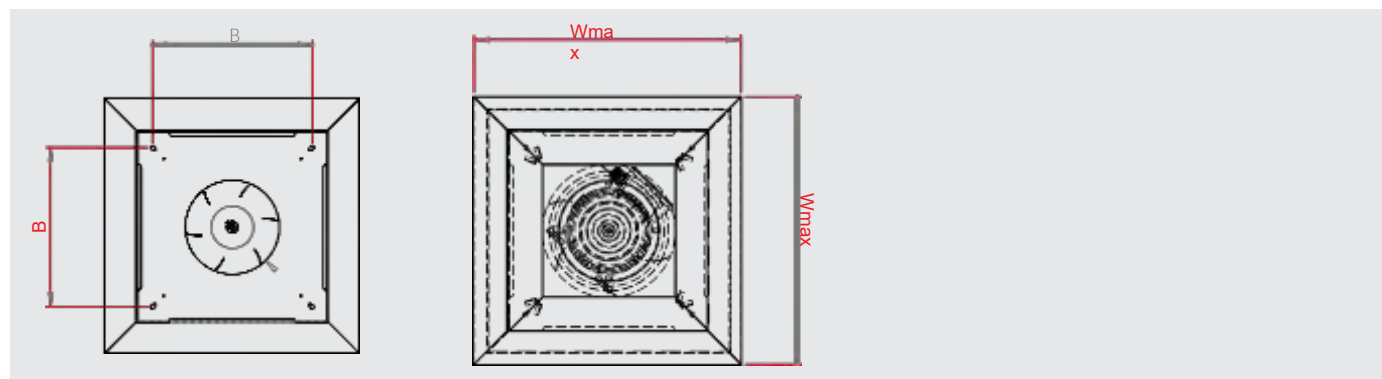

Technical Characteristics

MODELS	FLOW (m³/h)	POWER (kW)	VOLTAGE (V)	CURRENT (A)	SPEED (rpm)	FREQ. (Hz)	NOISE (dB(A))	B (mm)	DIMENSIONS Wmax (mm)	Hmax (mm)
P-DCF V 315 M	1950	0,25	230	1.80	1450	50	53	0	0	0
P-DCF V 355 M	2900	0,25	230	1.80	1450	50	55	530	590	750
P-DCF V 400 M	4000	0,37	230	2.60	1450	50	60	580	640	750
P-DCF V 450 M	5550	0,55	230	3.80	1450	50	62	630	690	750
P-DCF V 500 M	8400	1,1	230	7.10	1450	50	64	680	740	750
P-DCF V 560 M	10800	2,2	230	13.40	1450	50	66	730	790	750
P-DCF V 315 T	1950	0,25	380	0.81	1450	50	53	0	0	0
P-DCF V 355 T	2900	0,25	380	0.81	1450	50	55	530	590	750
P-DCF V 400 T	4000	0,37	380	1.15	1450	50	60	580	640	750
P-DCF V 450 T	5550	0,55	380	1.60	1450	50	62	630	690	750
P-DCF V 500 T	8400	1,1	380	2.60	1450	50	64	680	740	750
P-DCF V 560 T	10800	2,2	380	4.90	1450	50	66	730	790	750

Performance Curves

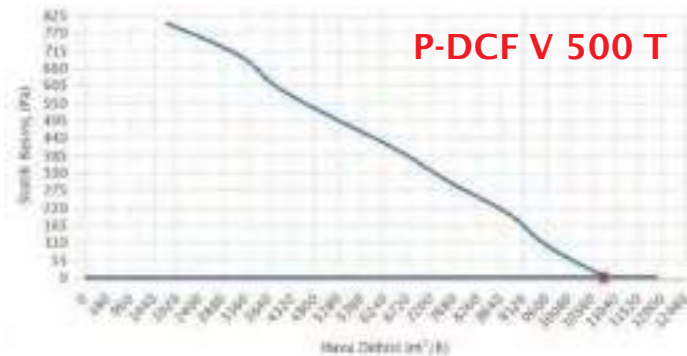
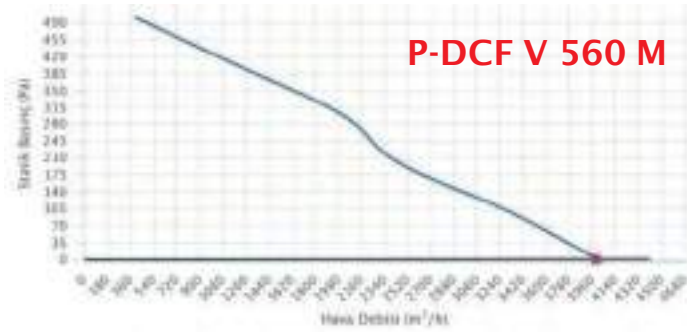
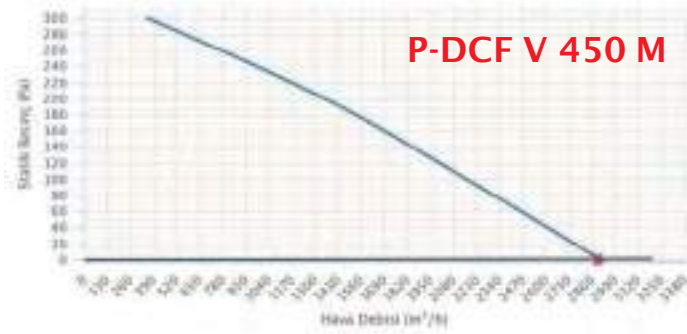
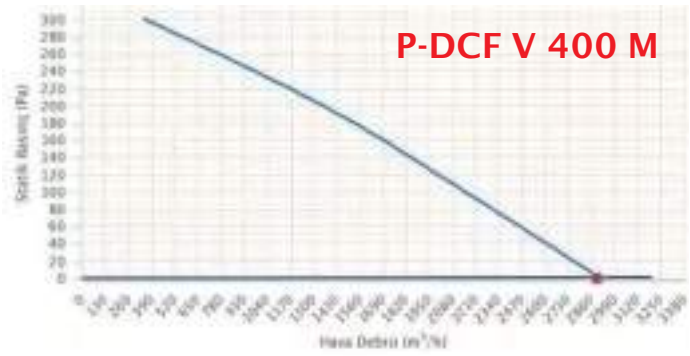

Performance Curves

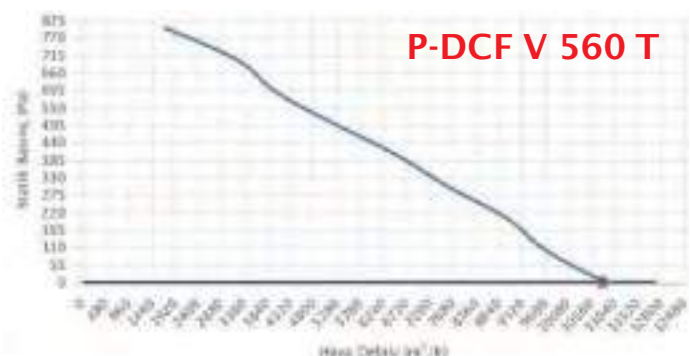
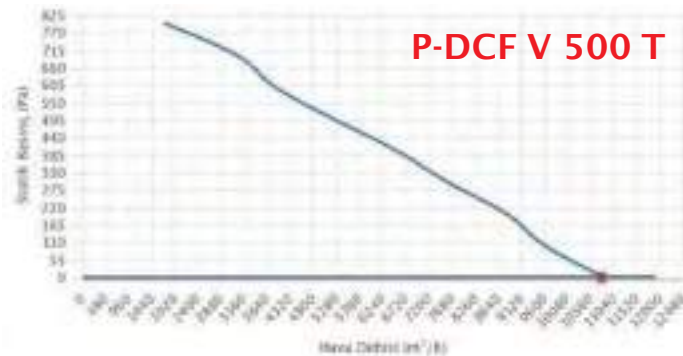
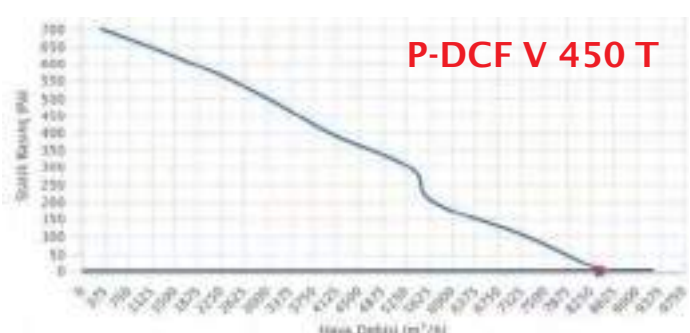
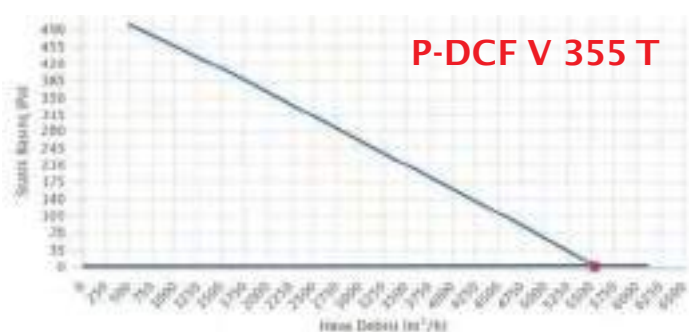
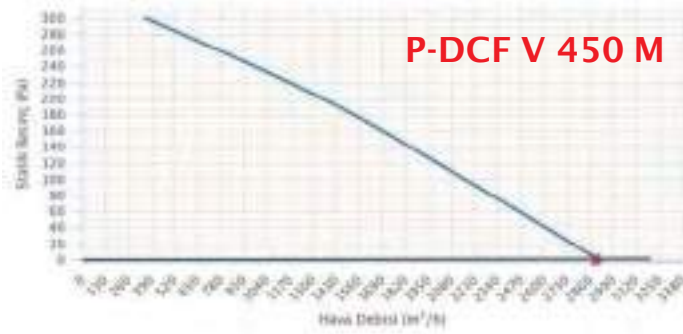
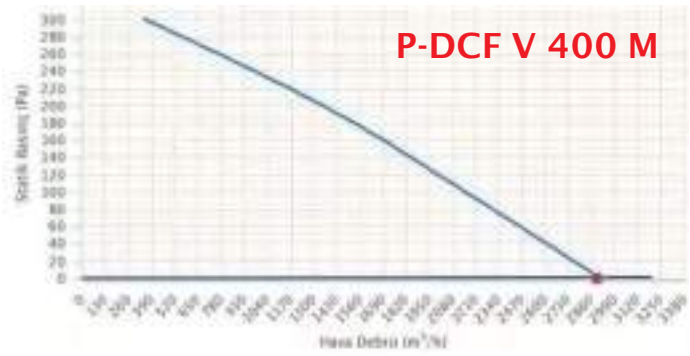
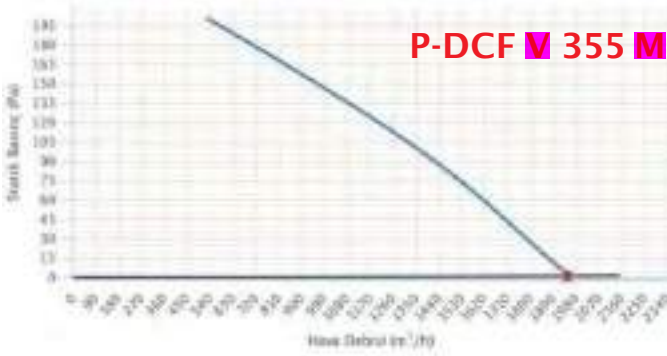

Horizontal Flow (EXT. Motor) Radial Roof Type Fan

DCF



Utilization Areas



Description

- * Water proof
- * Ip55 motor protec. class
- * Guard Cage
- * Single or tri-phase motor
- * Low energy consumption
- * Low noise level
- * Easy Installation
- * EXT. motor

Technical Drawing

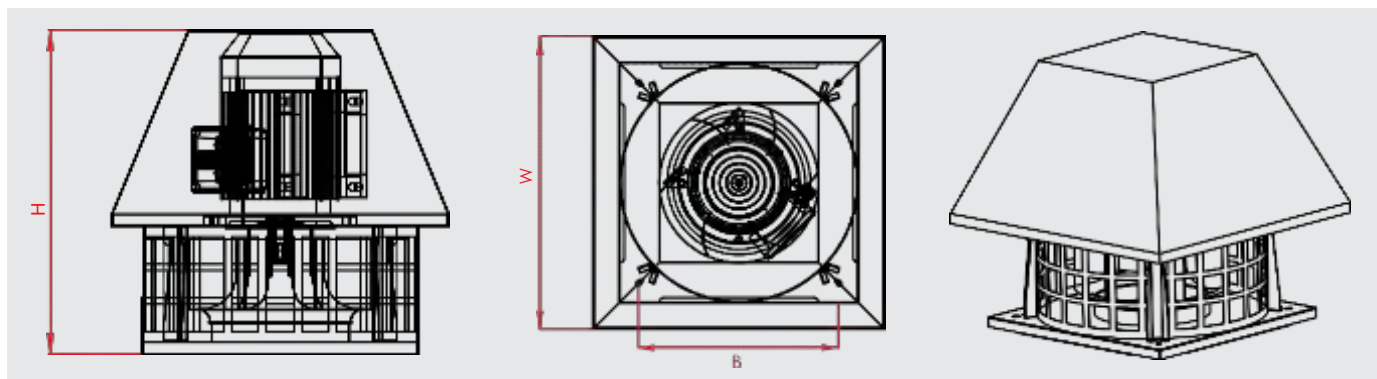

Technical Characteristics

MODELS	FLOW (m³/h)	POWER (Kw)	VOLTAGE (V)	CURRENT (A)	SPEED (rpm)	FREQ. (Hz)	NOISE (dbA)	B (mm)	DIMENSIONS W (mm)	H (mm)
P-DCF 280 M	1000	0.25	230	2	1500	50	53	330	452	750
P-DCF 315 M	1950	0.25	230	2	1500	50	53	350	420	750
P-DCF 355 M	2900	0.25	230	2.00	1500	50	55	370	445	750
P-DCF 400 M	4000	0.37	230	3.20	1500	50	60	420	490	750
P-DCF 450 M	5550	0.55	230	4.20	1500	50	62	460	540	750
P-DCF 500 M	8400	1.1	230	7.10	1500	50	64	490	590	750
P-DCF 560 M	10800	2.20	230	13.40	1500	50	66	540	640	750
P-DCF 280 T	1000	0.25	380	0.80	1500	50	53	330	452	750
P-DCF 315 T	1950	0.25	380	0.80	1500	50	53	350	420	750
P-DCF 355 T	2900	0.25	380	0.80	1500	50	55	370	445	750
P-DCF 400 T	4000	0.37	380	1.15	1500	50	60	420	490	750
P-DCF 450 T	5550	0.55	380	1.6	1500	50	62	460	540	750
P-DCF 500 T	8400	1.1	380	2.6	1500	50	64	490	590	750
P-DCF 560 T	10800	2.2	380	5	1500	50	66	540	640	750

Performance Curves

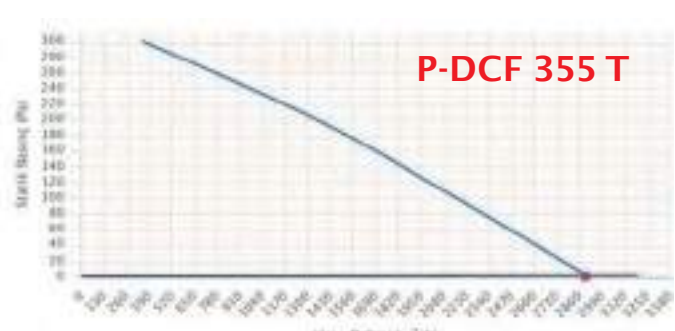
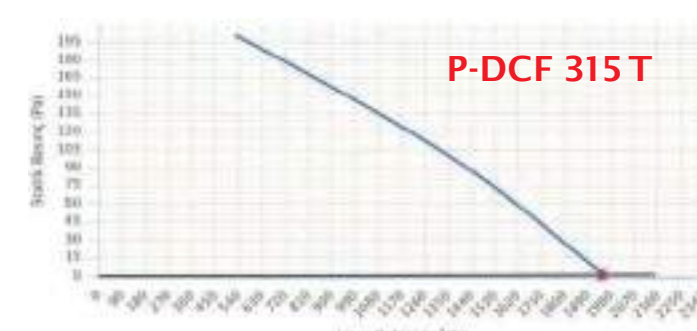
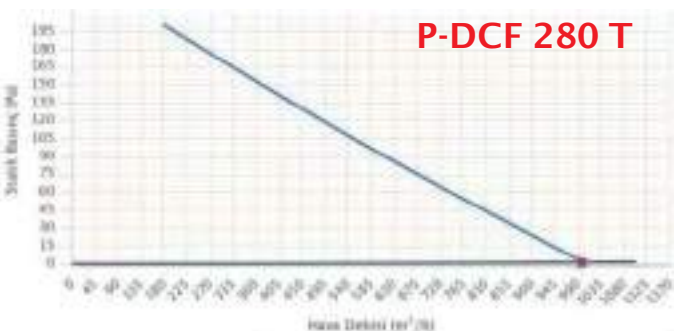
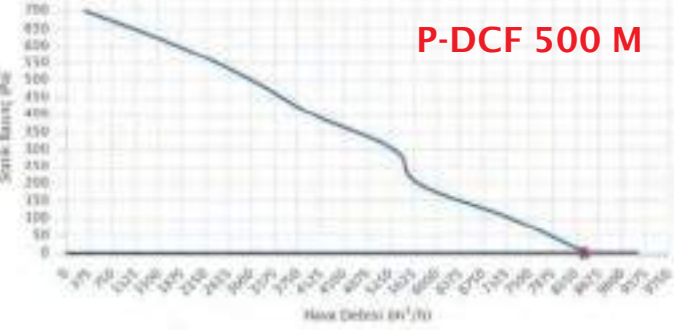
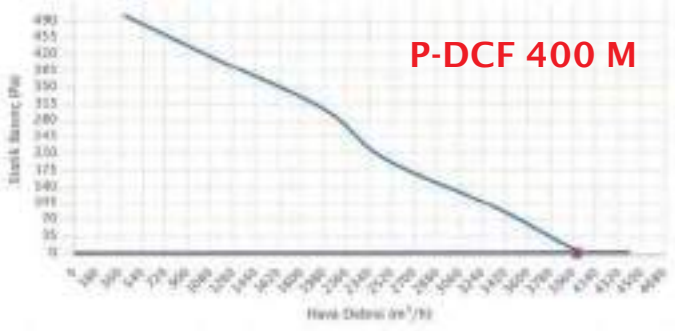
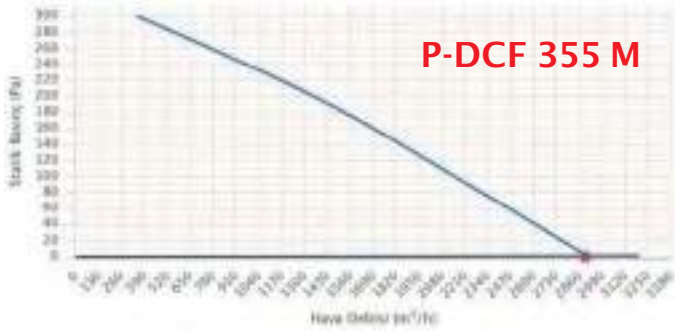
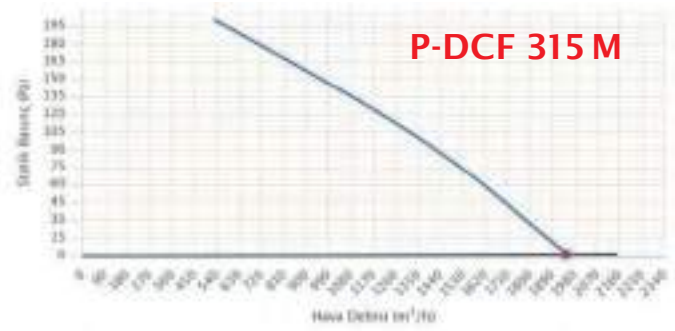
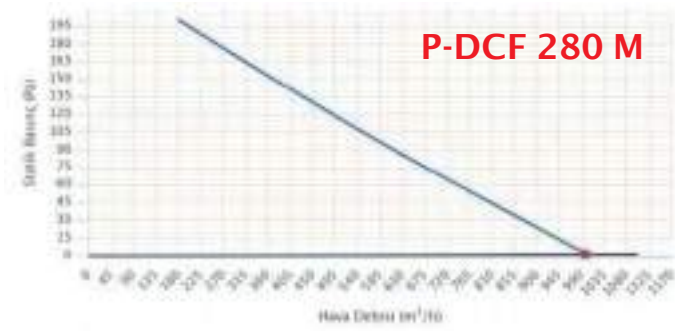

Performance Curves

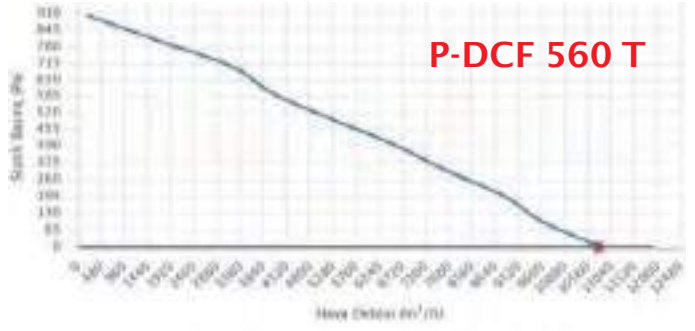
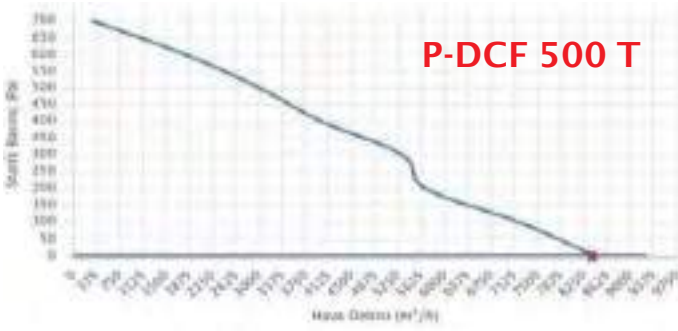
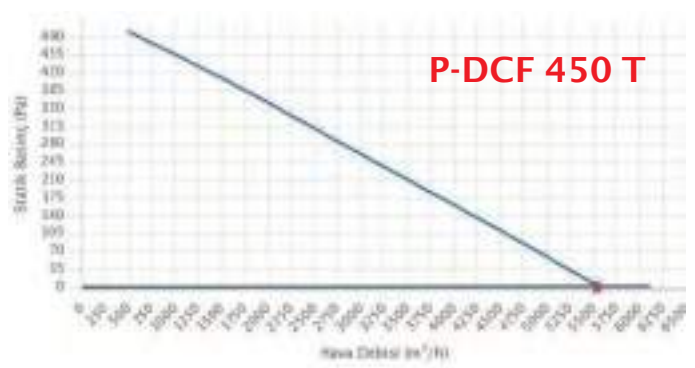
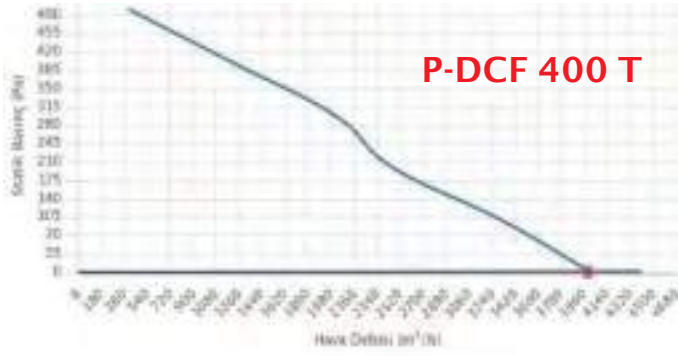

Horizontal Flow (EXT. Motor, Ex-Proof) Radial Roof Type Fan

DCF-EX



Utilization Areas



Description

- * EXT. motor
- * Low noise level
- * Thermic Protection
- * Ex-Proof Motor
- * Low Power Consumption
- * Easy installation and maintenance

Technical Drawing

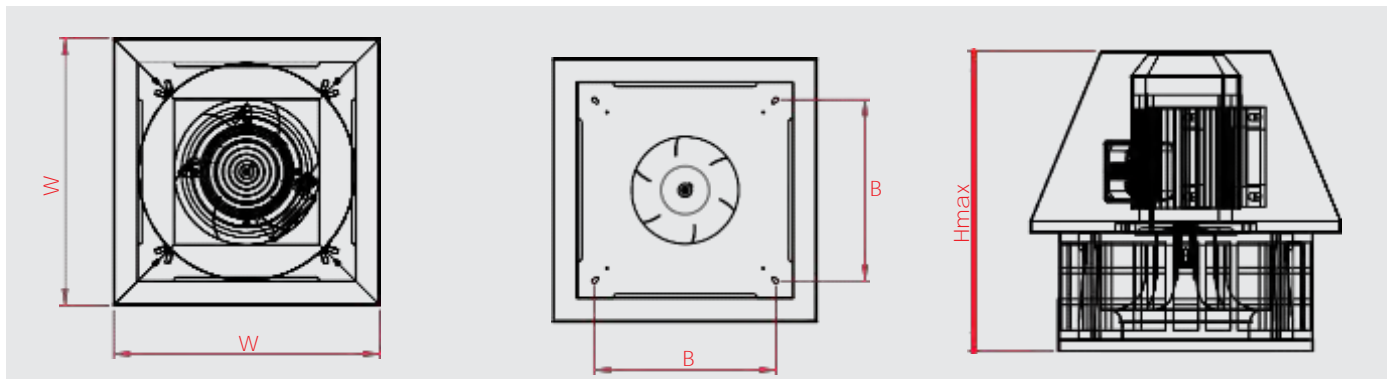

Technical Characteristics

MODELS	FLOW (m³/h)	POWER (kW)	VOLTAGE (V)	CURRENT (A)	SPEED (rpm)	FREQ. (Hz)	NOISE (dbA)	B (mm)	DIMENSIONS Hmax (mm)	W (mm)
P-DCF EX 280 T	1000	0,25	380	0,8	1500	50	53	330	750	452
P-DCF EX 315 T	1950	0,25	380	0,8	1500	50	53	404	750	454
P-DCF EX 355 T	2900	0,25	380	0,80	1500	50	55	370	750	445
P-DCF EX 400 T	4000	0,37	380	1,15	1500	50	60	420	750	490
P-DCF EX 450 T	5550	0,55	380	1,60	1500	50	62	460	750	540
P-DCF EX 500 T	8400	1,1	380	2,70	1500	50	64	490	750	590
P-DCF EX 560 T	10800	2,20	380	3,60	1500	50	66	540	750	640
P-DCF EX 630 T	13100	3,00	380	7,40	1000	50	60	660	750	730
P-DCF EX 710 T	15000	4,00	380	9,40	1000	50	63	710	750	780
P-DCF EX 800 T	17000	7,50	380	16,00	1000	50	67	850	750	900

Performance Curves

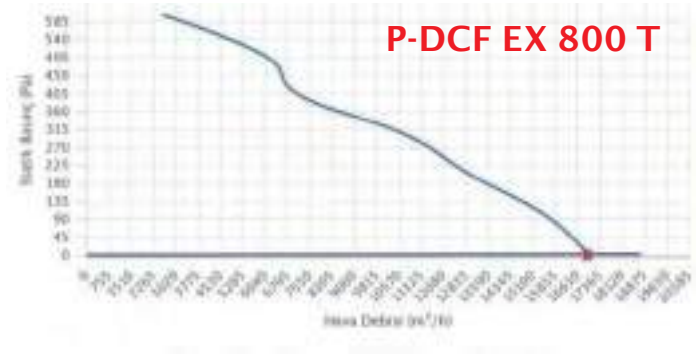
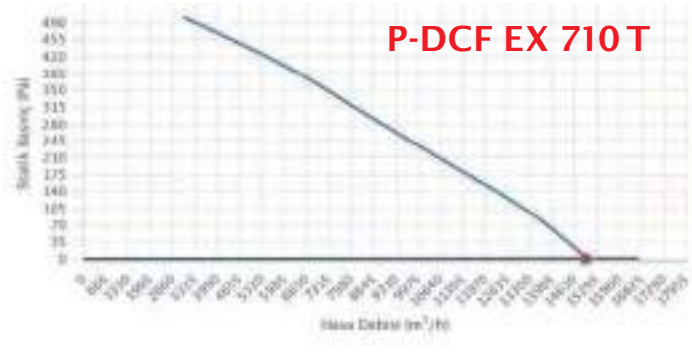
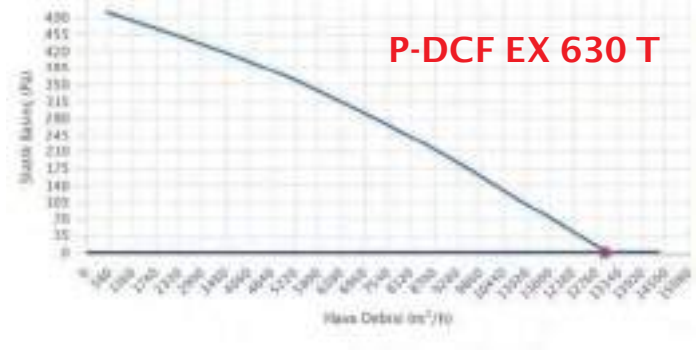
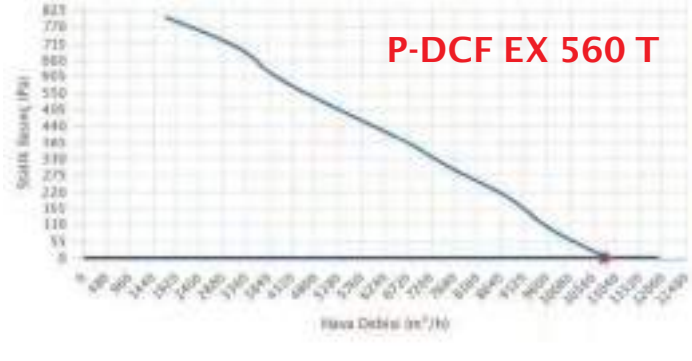
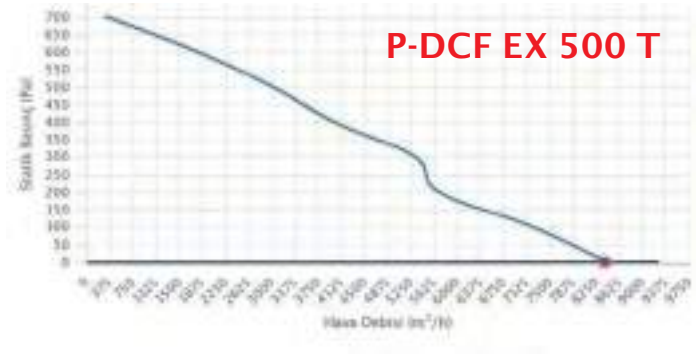
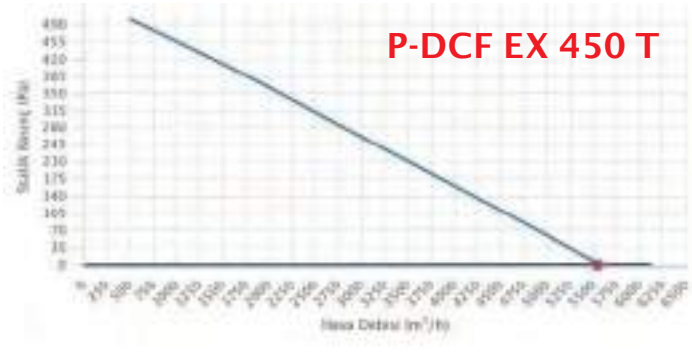
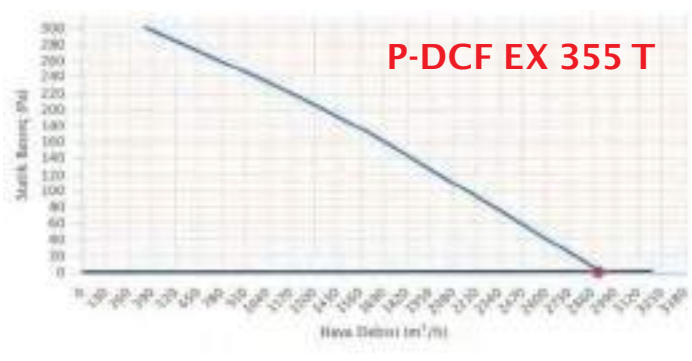
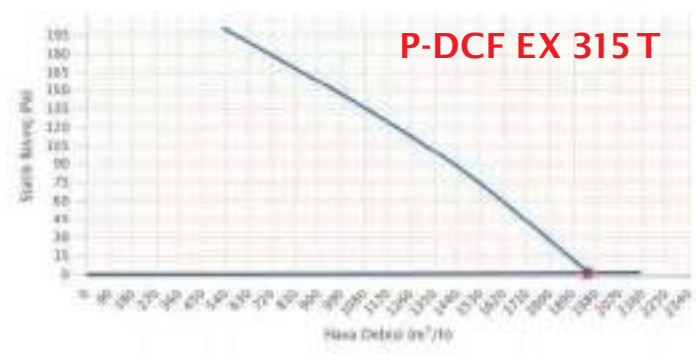
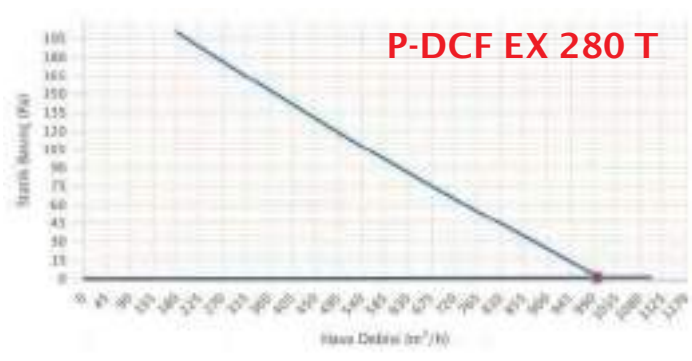

Horizontal Flow (EXT. Motor, Chimney Hood) Radial Roof Type Fan

DCF-M



Utilization Areas



Description

- * Low noise level
- * Low energy consumption
- * Easy installation and maintenance
- * Thermic Protection
- * Guard Cage

Technical Characteristics

MODELS	FLOW (m ³ /h)	POWER (kW)	VOLTAGE (V)	CURRENT (A)	SPEED (rpm)	FREQ. (Hz)	NOISE (dbA)	A (mm)	DIMENSIONS		H (mm)
									B (mm)	C (mm)	
P-DCF 315-1 M	1950	0,25	230	1.80	3000	50	53	455	455	595	555

Performance Curves

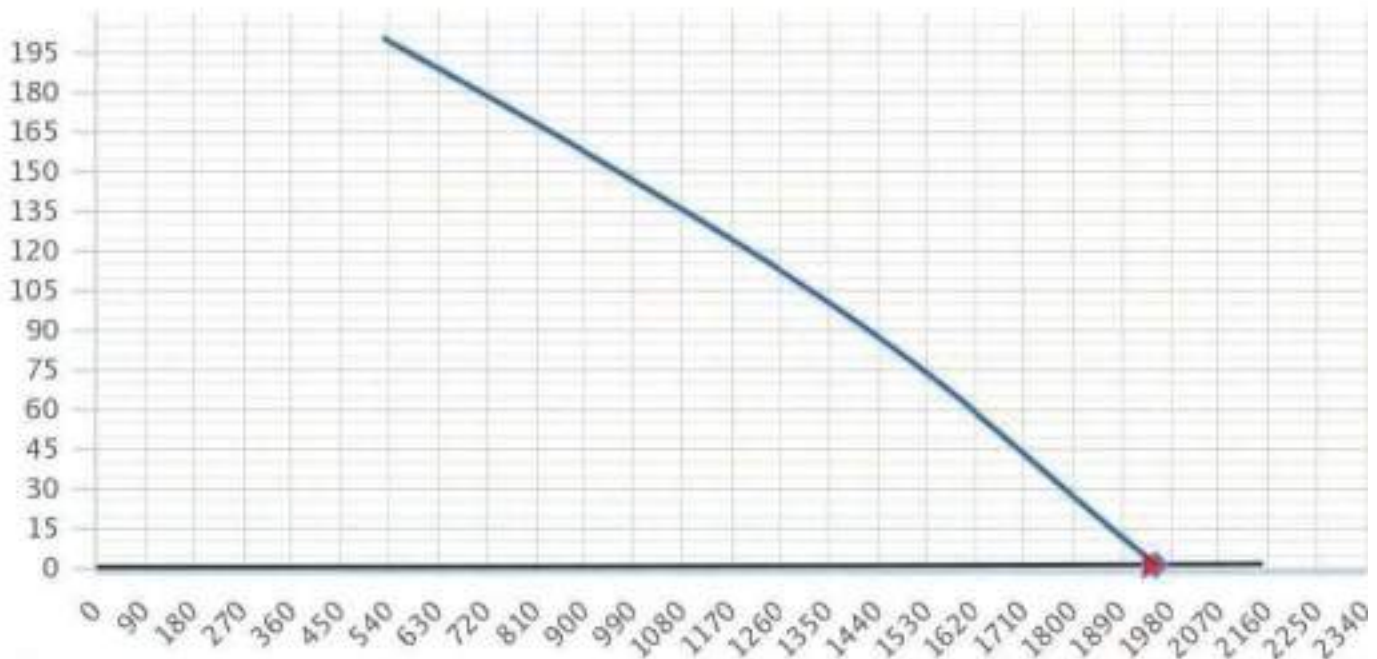

Horizontal Flow (Internal EC Motor) Radial Roof Type Fan

CF-EC



Utilization Areas



Description

- * Backward Curved Radial Blades
- * High Pressure
- * Low noise level
- * Low Turbulance
- * Low energy consumption
- * Smaller motor for the same efficiency

Technical Drawing

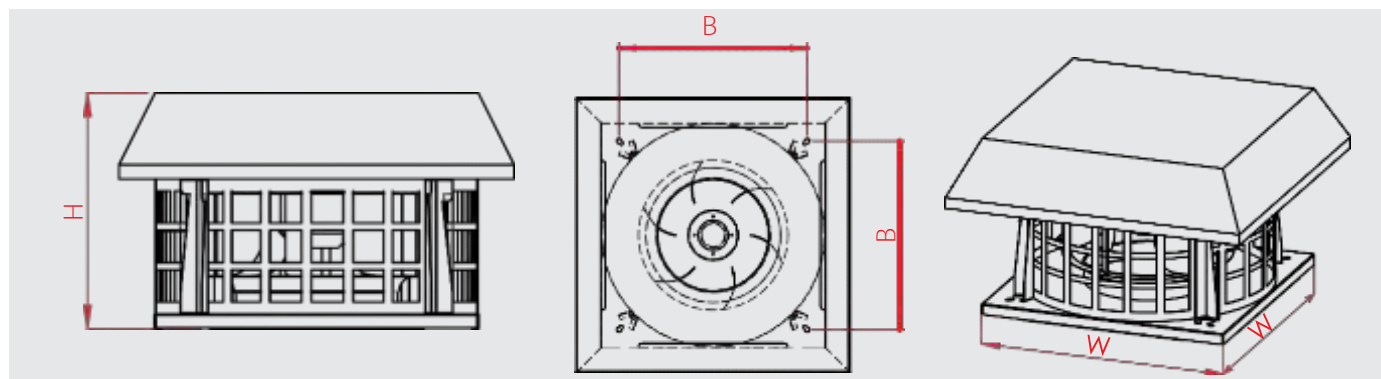

Technical Characteristics

MODELS	FLOW (m³/h)	POWER (W)	VOLTAGE (V)	CURRENT (A)	SPEED (rpm)	FREQ. (Hz)	NOISE (dbA)	B (mm)	DIMENSIONS W (mm)	H (mm)
P-CF 180-EC	670	0,10	230	0,77	3520	50	52	203	250	180
P-CF 225-EC	1290	0,10	230	0,8	2400	50	47	270	340	235
P-CF 250-EC	1470	0,16	230	1,29	3300	50	54	305	370	235
P-CF 280-EC	2330	0,18	230	1,34	2610	50	48	330	452	235
P-CF 355-EC	3830	0,67	230	3,36	1550	50	51	370	445	330
P-CF 400-EC	5380	0,53	230	3,90	1450	50	58	420	490	370
P-CF 450-EC	8110	1,32	230	3,27	1560	50	63	460	540	440
P-CF 500-EC	10900	1,35	380	2,08	1480	50	67	490	590	490
P-CF 560-EC	13640	2.14	380	3,83	1540	50	69	540	640	550

Performance Curves

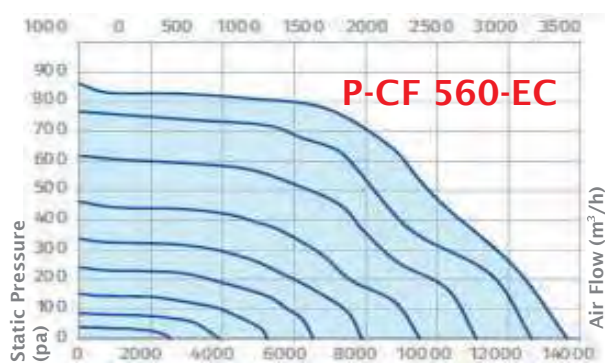
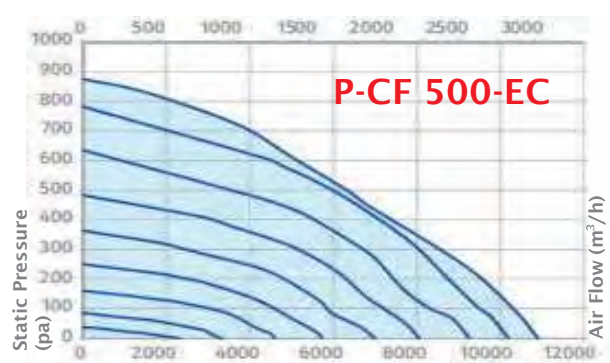
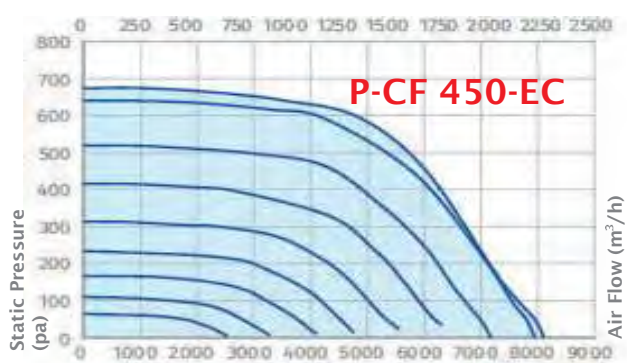
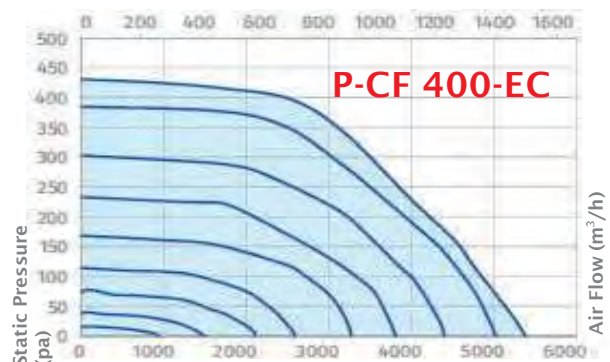
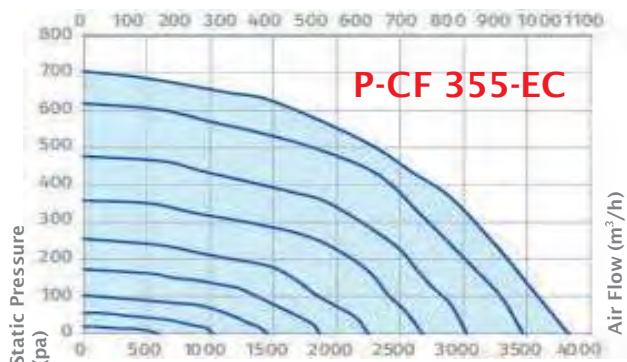
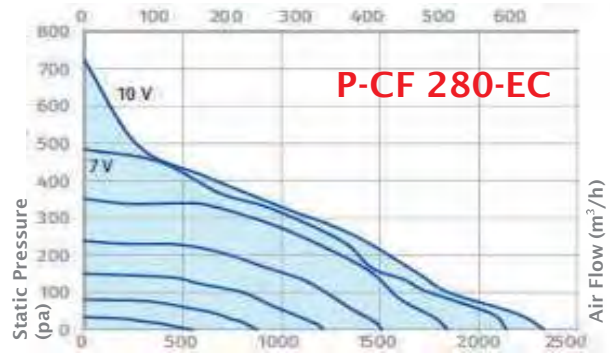
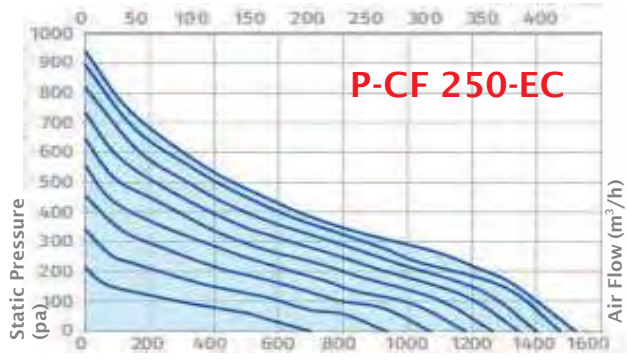
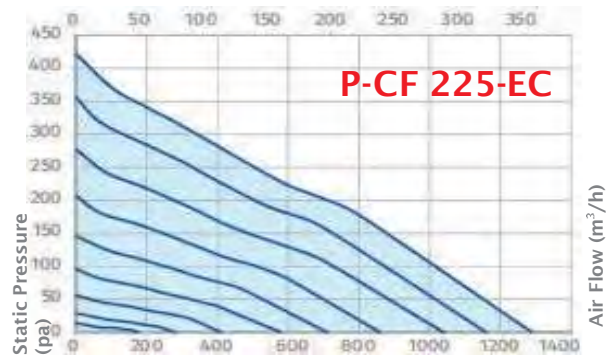
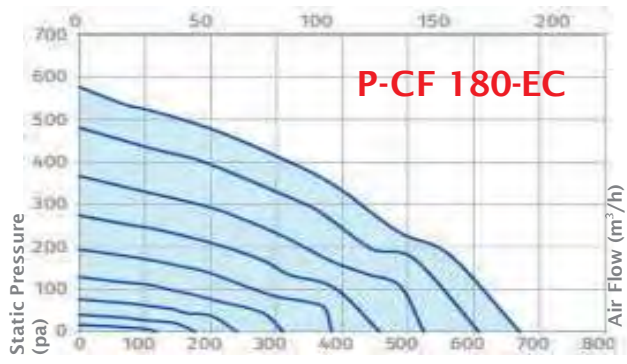

Horizontal Flow (Internal Motor) Roof Type Axial Fan

ACF



Utilization Areas



Description

- * Waterproof Özelliği
- * Low noise level
- * Low energy consumption
- * IP55 protection
- * Thermic Protection
- * Easy installation

Technical Drawing

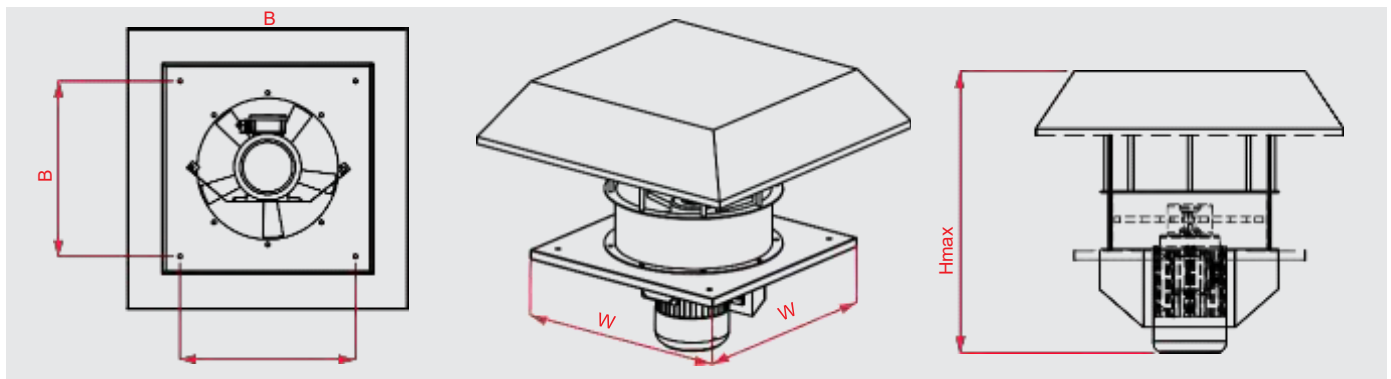

Technical Characteristics

MODELS	FLOW (m ³ /h)	POWER (kW)	VOLTAGE (V)	CURRENT (A)	SPEED (rpm)	FREQ. (Hz)	NOISE (dBa)	B (mm)	DIMENSIONS Hmax (mm)	W (mm)
P-ACF 400	5500	0.25	380	0.8	1500	50	51	500	350	600
P-ACF 450	7000	0.37	380	1.15	1500	50	55	550	350	650
P-ACF 500	8500	0.55	380	1.60	1500	50	57	600	350	700
P-ACF 560	10500	0.55	380	1.60	1500	50	61	660	350	760
P-ACF 630	12500	0.75	380	2.00	1500	50	63	730	350	830
P-ACF 710 A	16500	1.5	380	3.50	1500	50	68	810	350	910
P-ACF 710 B	18500	2.20	380	5.00	1500	50	68	810	350	910
P-ACF 710 C	24000	3.00	380	6.60	1500	50	68	810	350	910
P-ACF 800	28500	3.00	380	6.60	1500	50	70	900	450	1000
P-ACF 900	35000	4.00	380	8.40	1500	50	74	1000	450	910
P-ACF 1000	46000	5.5	380	11.2	1500	50	77	1000	450	1200

Performance Curves

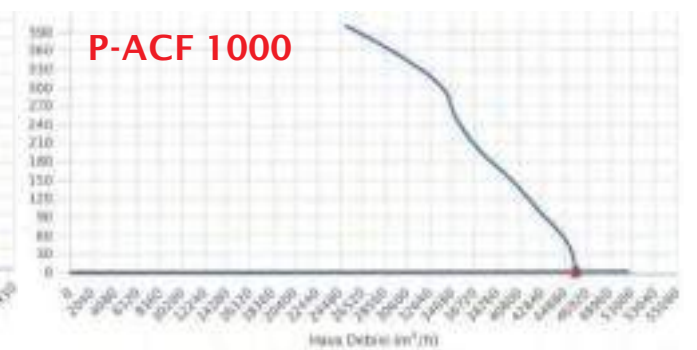
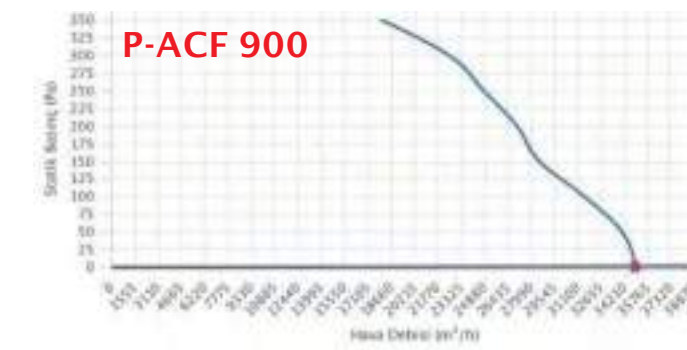
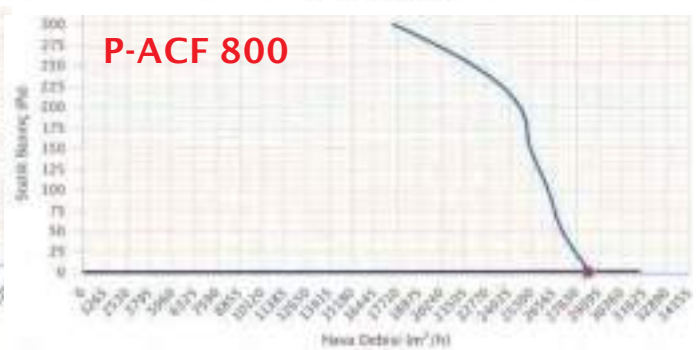
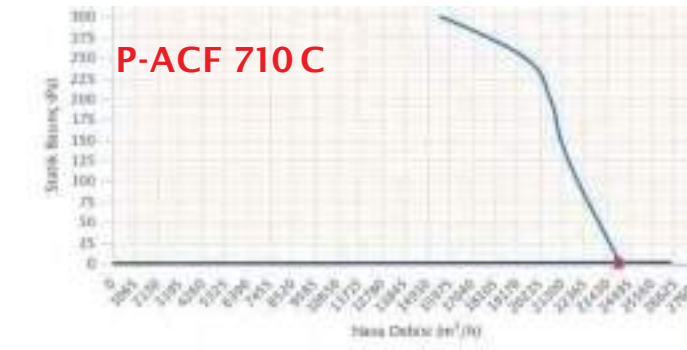
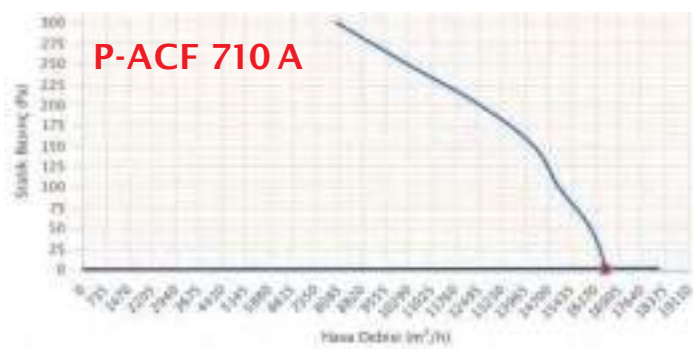
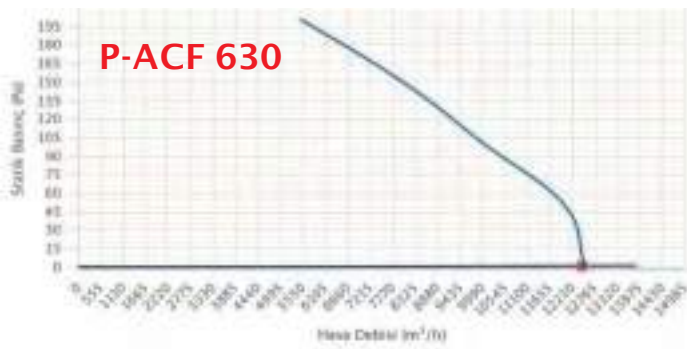
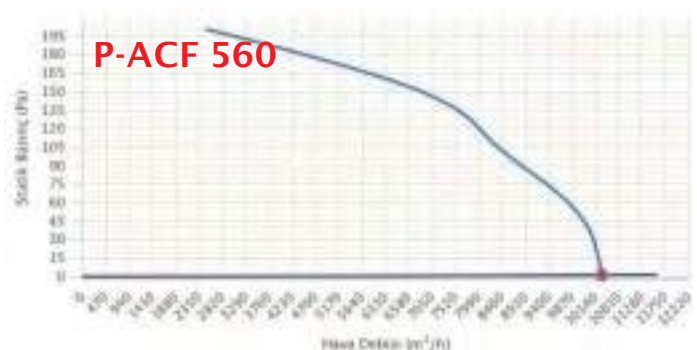
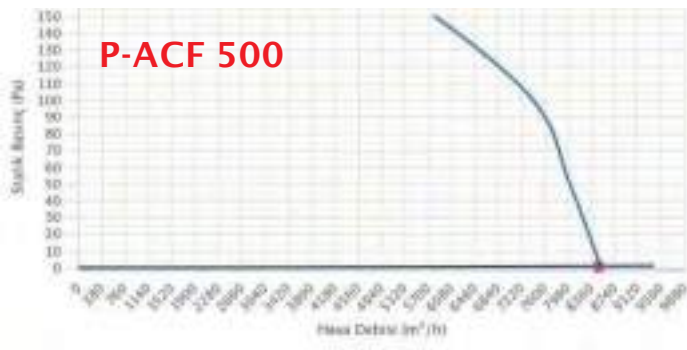
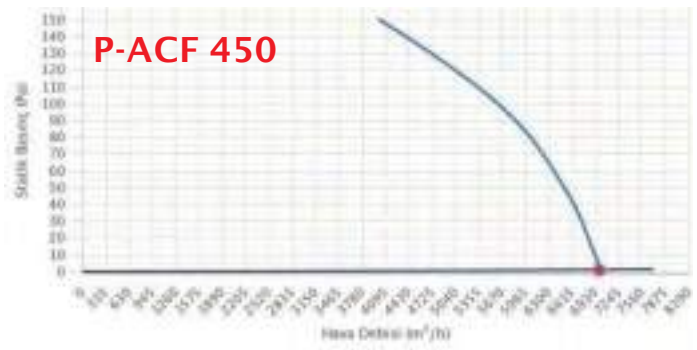
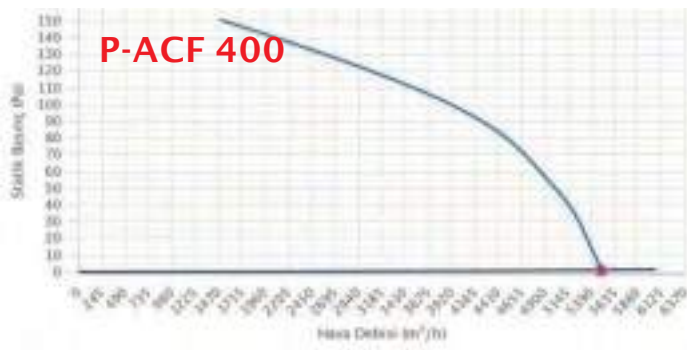

Pocket Type Shelter Ventilator

SV

point®



Utilization Areas



Description

- * Low noise level
- * G4 fiber filter
- * Activated Carbon Filter
- * IP44 motor protection
- * Lead separator (Optional)
- * By-pass system
- * Lead coating (Optional)
- * Self-flanged structure

Technical Drawing

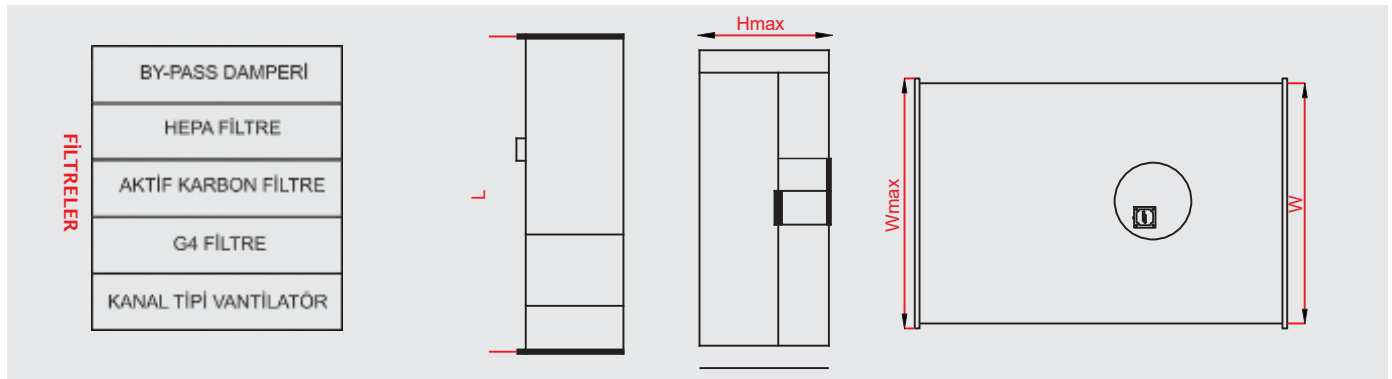

Technical Characteristics

MODELS	FLOW (m³/h)	POWER (kW)	VOLTAGE (V)	CURRENT (A)	SPEED (rpm)	FREQ. (Hz)	NOISE (dbA)	H (mm)	W (mm)	DİMENSİ ONS Hmax (mm)	Wmax (mm)	L (mm)
P-SV 225	500	0,1	230	0,6	3000	50	55	245	500	300	565	765
P-SV 250	800	0,13	230	1,05	3000	50	60	245	500	300	565	765
P-SV 280	1000	0,18	230	1,10	3000	50	65	245	500	300	565	765
P-SV 355	2000	0,14	230	1,50	1500	50	70	345	600	400	665	865
P-SV 400	3000	0,38	230	3,50	1500	50	75	345	600	400	665	865
P-SV 450	4000	0,69	230	2,50	1500	50	80	585	775	635	825	950
P-SV 500	6000	1,08	230	2,60	1500	50	85	620	810	670	860	950
P-SV 560	8000	1,67	230	3,00	1500	50	90	620	810	670	860	950

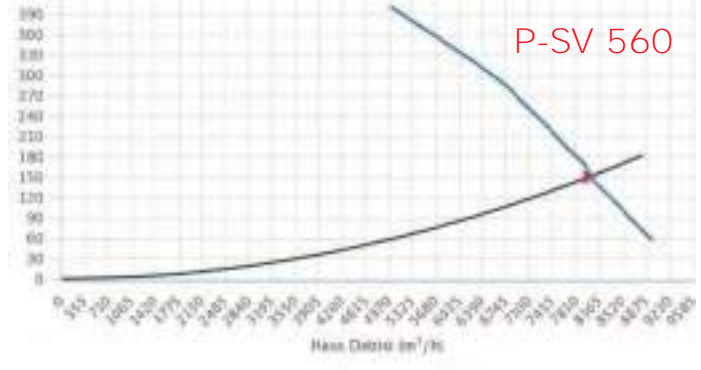
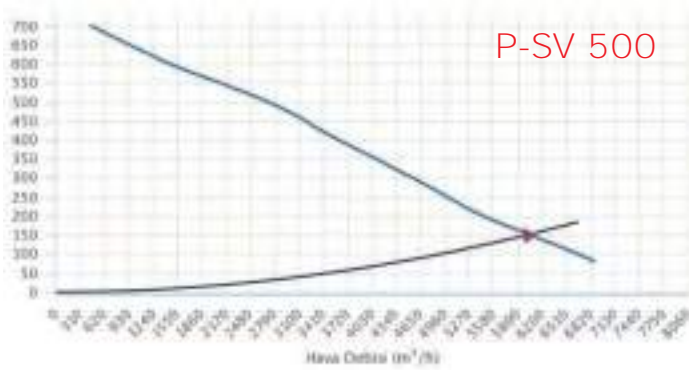
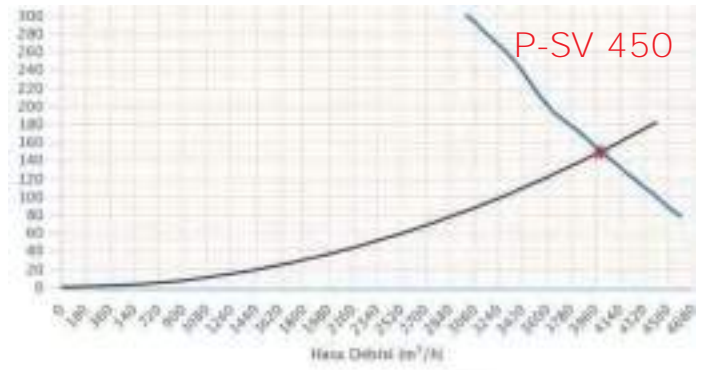
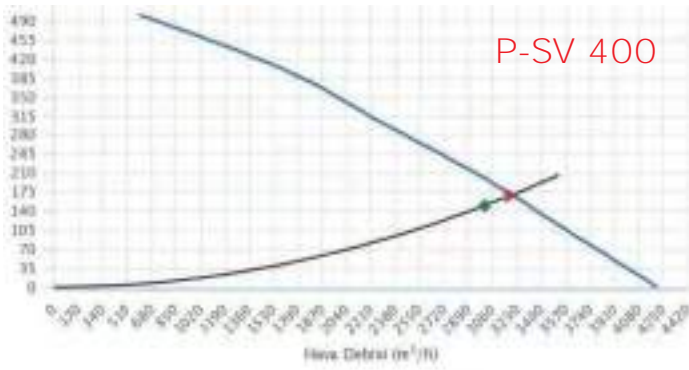
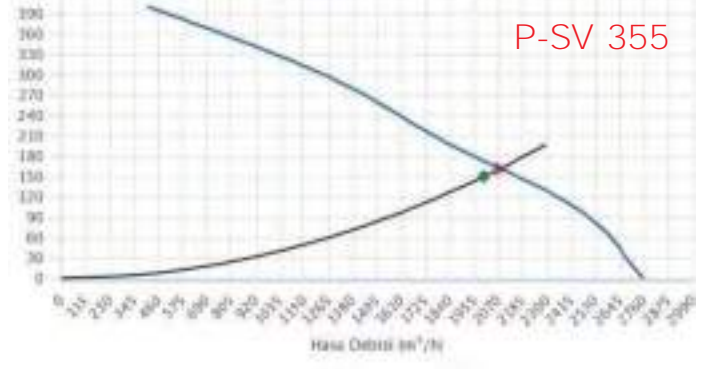
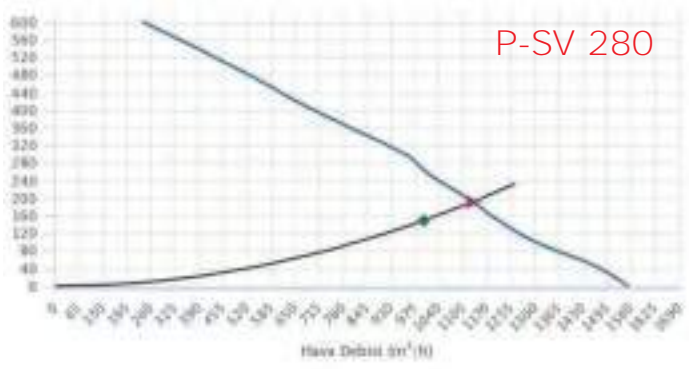
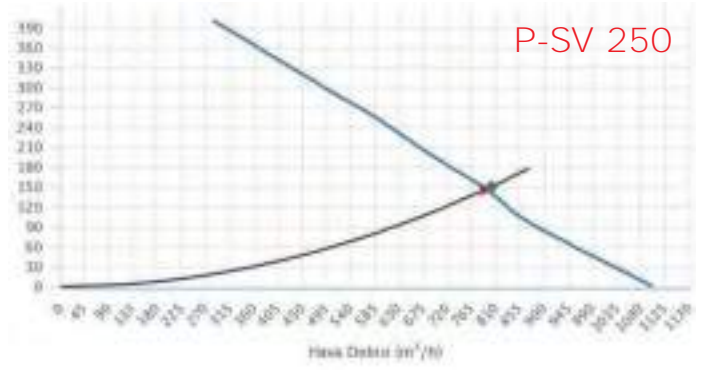
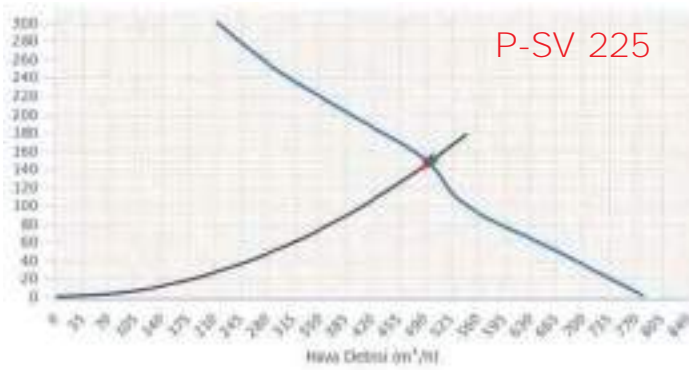

W Module Shelter Ventilator

SV-W



Utilization Areas



Description

- * Low noise level
- * G4 elyaf filtre
- * Aktif karbon filtre
- * IP44 motor protection
- * Lead separator (Optional)
- * By-pass system
- * Lead coating (Optional)
- * Self-flanged structure

Technical Drawing

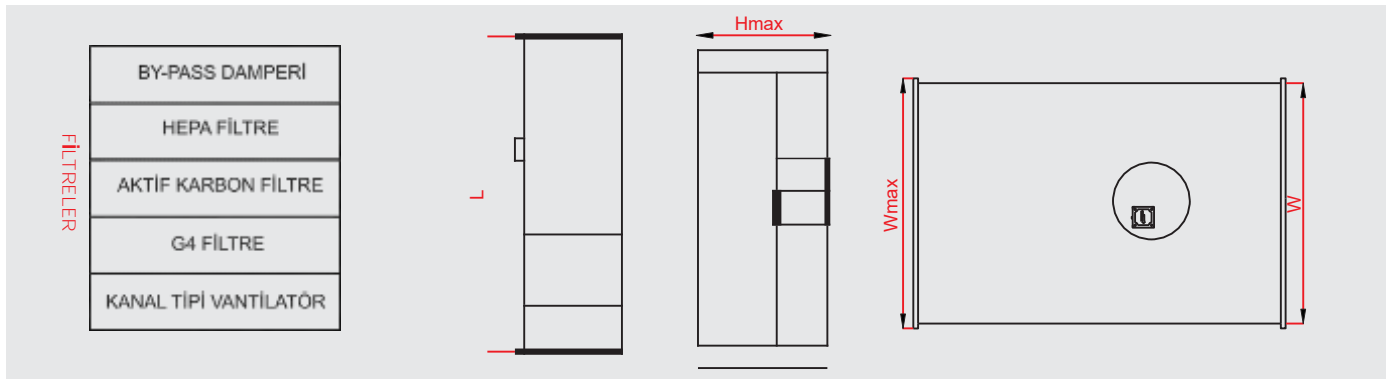

Technical Characteristics

MODELS	FLOW (m³/h)	POWER (kW)	VOLTAGE (V)	CURRENT (A)	SPEED (rpm)	FREQ. (Hz)	NOISE (dbA)	H (mm)	W (mm)	DİMENSİ ONS Hmax (mm)	Wmax (mm)	L (mm)
P-SV-W 225	500	0,1	230	0,6	3000	50	55	245	500	300	565	765
P-SV-W 250	800	0,13	230	1,05	3000	50	60	245	500	300	565	765
P-SV-W 280	1000	0,18	230	1,10	3000	50	65	245	500	300	565	765
P-SV-W 355	2000	0,14	230	1,50	1500	50	70	345	600	400	665	865
P-SV-W 400	3000	0,38	230	3,50	1500	50	75	345	600	400	665	865
P-SV-W 450	4000	0,69	230	2,50	1500	50	80	585	775	635	825	950
P-SV-W 500	6000	1,08	230	2,60	1500	50	85	620	810	670	860	950
P-SV-W 560	8000	1,67	230	3,00	1500	50	90	620	810	670	860	950

Performance Curves

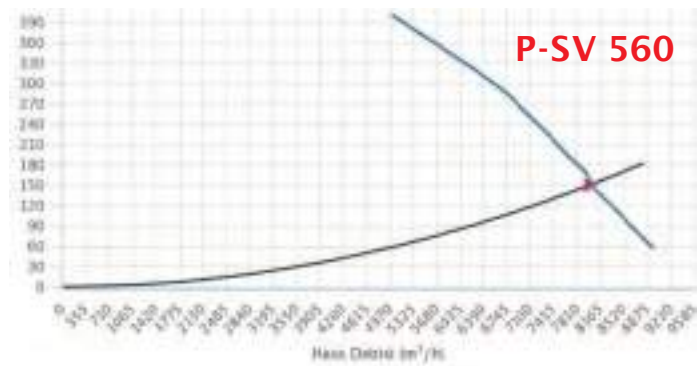
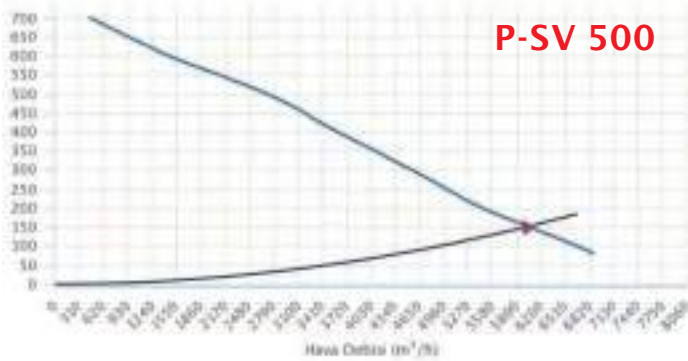
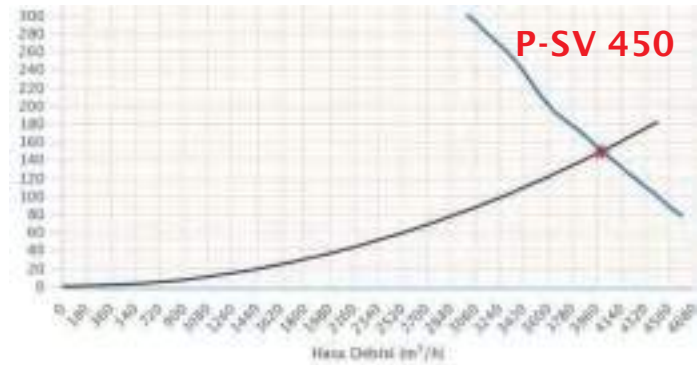
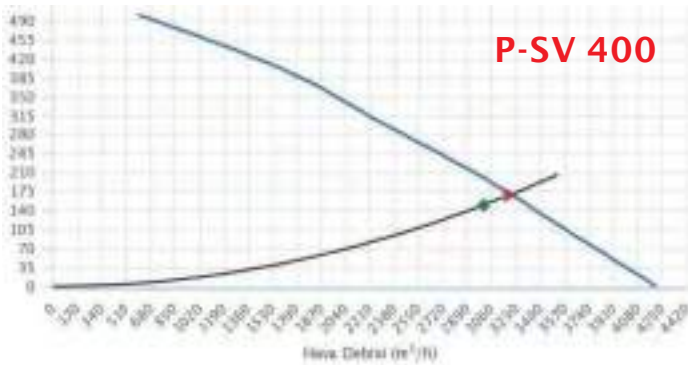
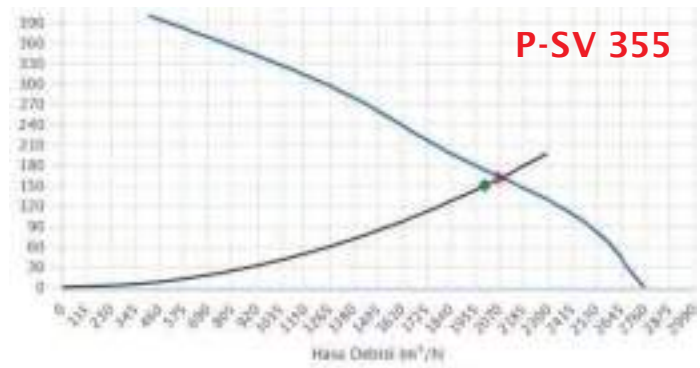
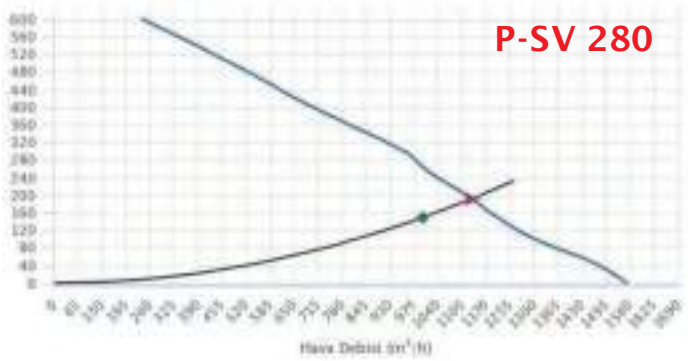
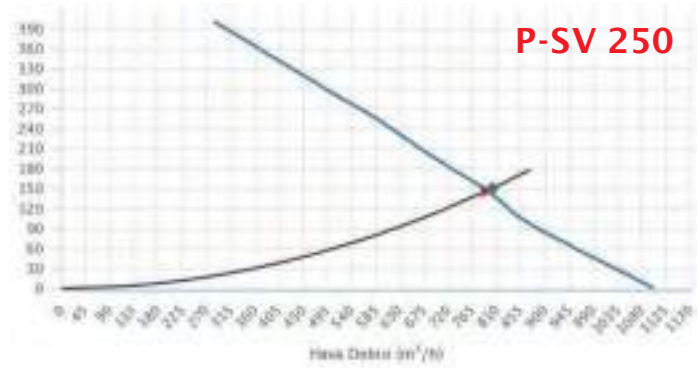
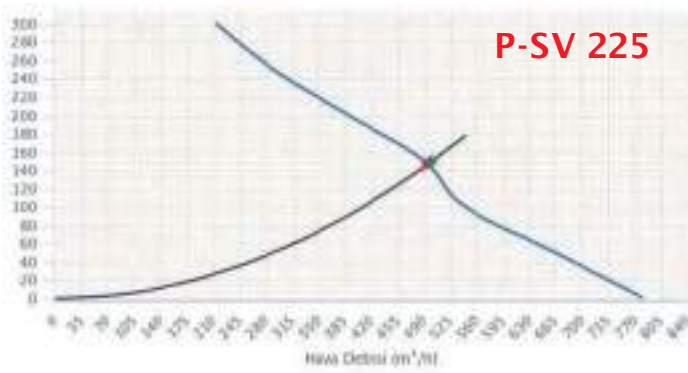

Cabinet/Cell Type Shelter Ventilator

HSV



Utilization Areas



Description

- * Low noise level
- * G4-Activated-Carbon-HEPA Filter
- * Double wall panels
- * Centrifugal or Plug Fan
- * IP55 protection
- * Easy maintenance
- * Volume Damper

Technical Drawing

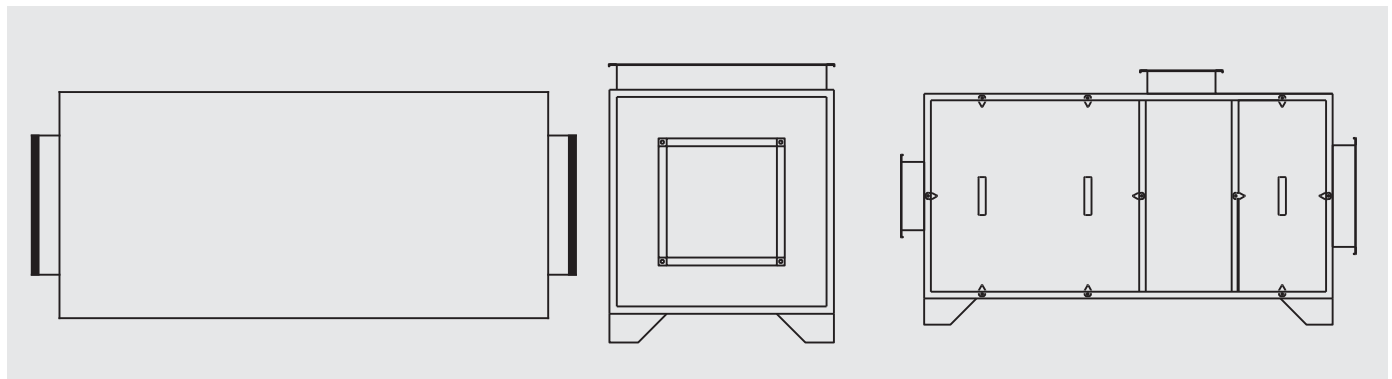

Technical Characteristics

MODELS	FLOW (m ³ /h)	POWER (W)	VOLTAGE (V)	SPEED (rpm)	FREQ. (Hz) 50	NOISE (dbA)
P-HSV-WM-1000	800-1000		380	3000	50	70
P-HSV-WM-1500	1200-1500	0,55	380	3000		75
P-HSV-WM-2000	1600-2000	0,75	380	3000	50	80
P-HSV-WM-2400	2100-2400	1,1	380	3000	50	85
P-HSV-WM-3000	2500-3000	1,5	380	3000	50	90
P-HSV-WM-5500	4500-5500	3,00	380	3000	50	95
P-HSV-WM-6500	5700-6500	4,00	380	3000	50	100
P-HSV-WM-7500	6600-7500	5,5	380	1500	50	110
P-HSV-WM-8500	7600-8500	5,5	380	1500	50	120

Performance Curves

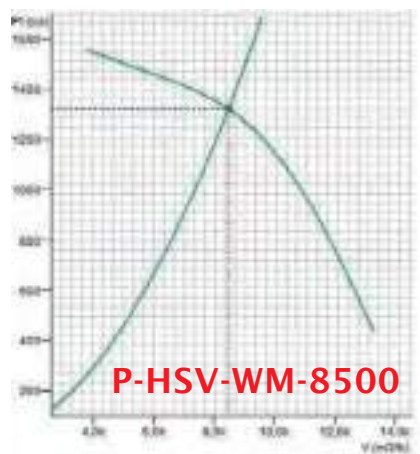
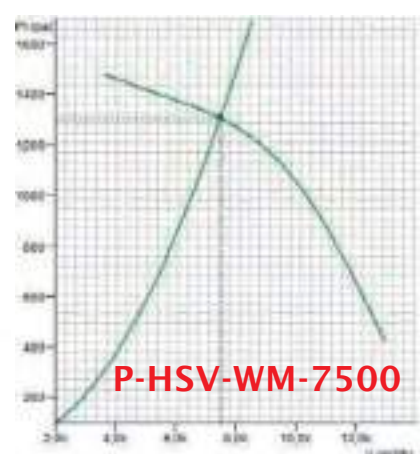
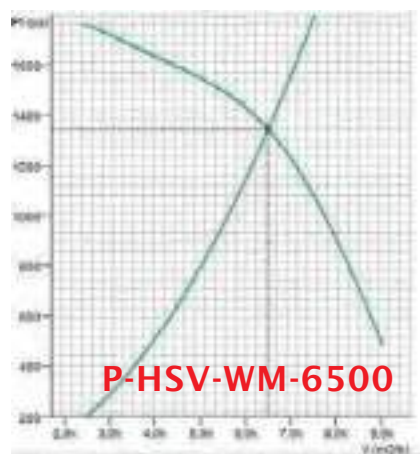
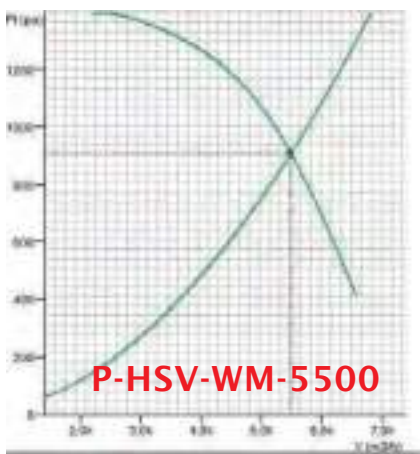
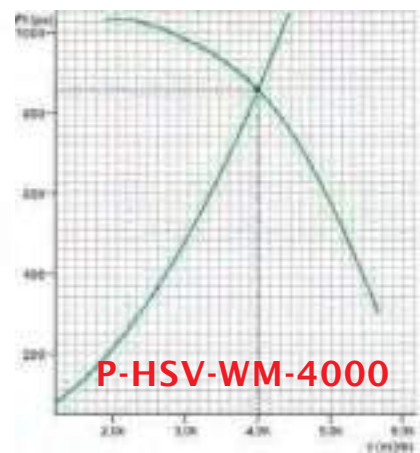
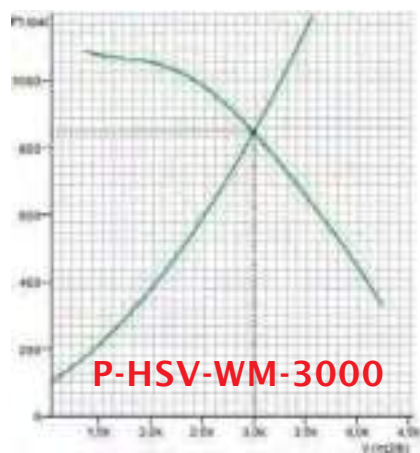
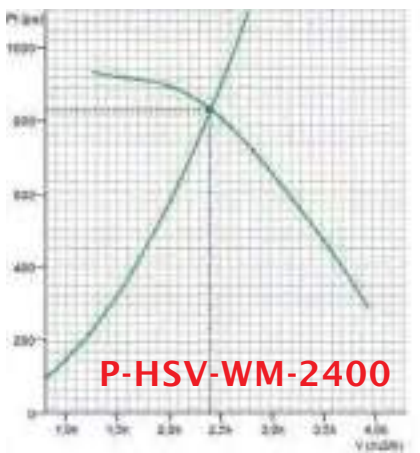
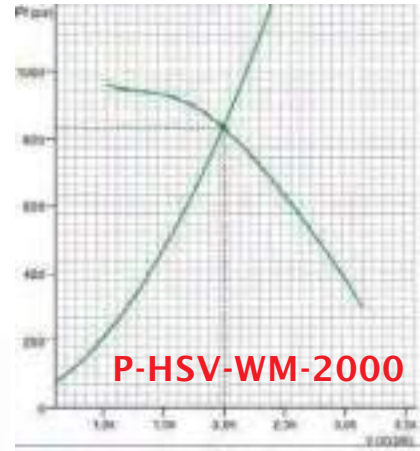
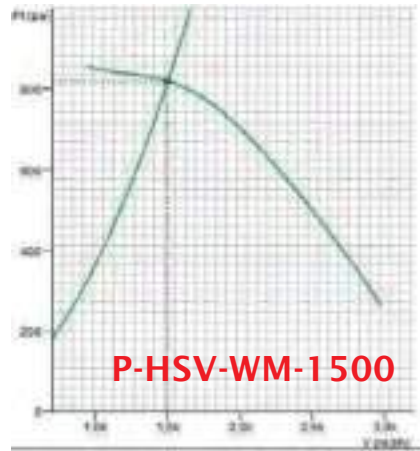
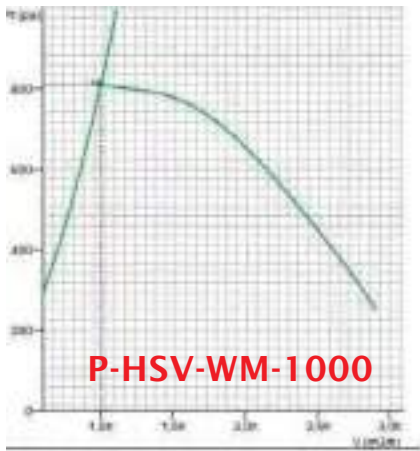

Low Pressure (Backward Curved Rare Blade) Centrifugal Blower

OBSF



Utilization Areas



Description

- * Adjustable blowing direction
- * Direct Drive Plug Fan
- * Electrostatic Powder Coating
- * Easy installation support
- * Single or tri-phase motor
- * Easy maintenance

Technical Drawing

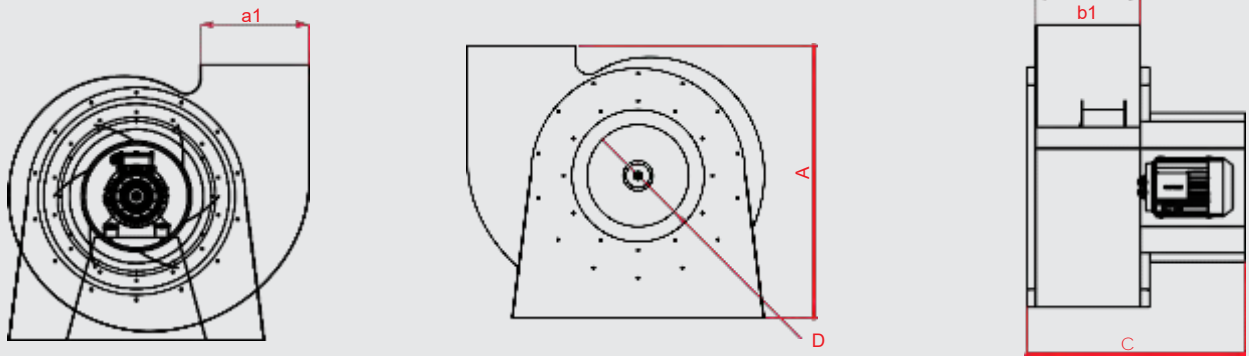

Technical Characteristics

MODELS	FLOW (m ³ /h)	POWER (W)	PRESSURE (pa)	VOLTAGE (V)	SPEED (rpm)	FREQ. (Hz)	NOISE (dbA)	A (mm)	C (mm)	Emiş Çapı D (mm)	Atış Ölçüsü a1xb1 (mm)
P-OBSF 50	5000	1,1	300	380	1500	50	89	555	610	320	300x300
P-OBSF 75	7500	1,5	300	380	1500	50	90	630	670	380	350x350
P-OBSF 100	10000	2,2	300	380	1500	50	90	715	710	440	400x350
P-OBSF 125	12500	3	300	380	1500	50	92	815	820	490	450x400
P-OBSF 150	15000	4	400	380	1500	50	93	930	890	540	500x450
P-OBSF 175	17500	5,5	400	380	1500	50	93	1050	965	600	550x500
P-OBSF 200	20000	7,50	700	380	1500	50	94	1135	990	610	600x500
P-OBSF 250	25000	11,00	700	380	1500	50	95	1230	1100	650	730x590

Performance Curves

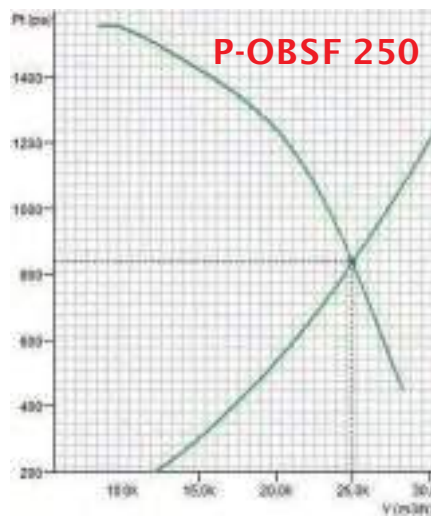
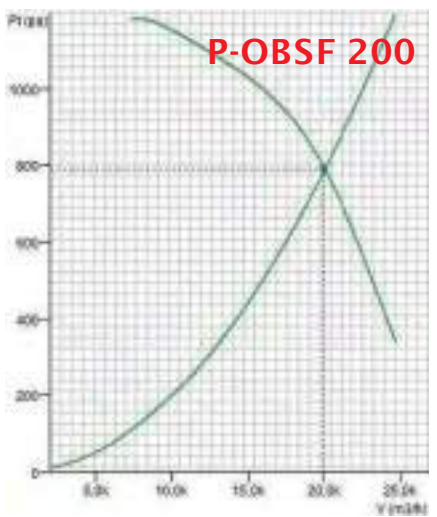
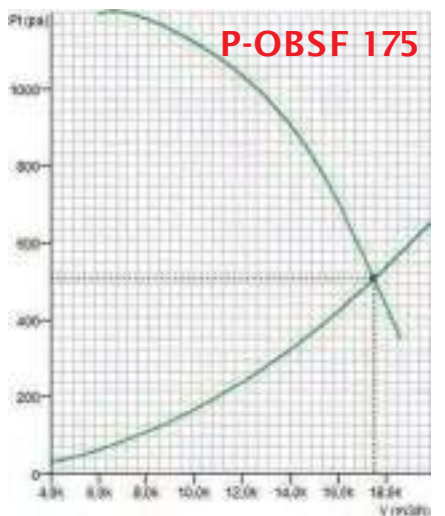
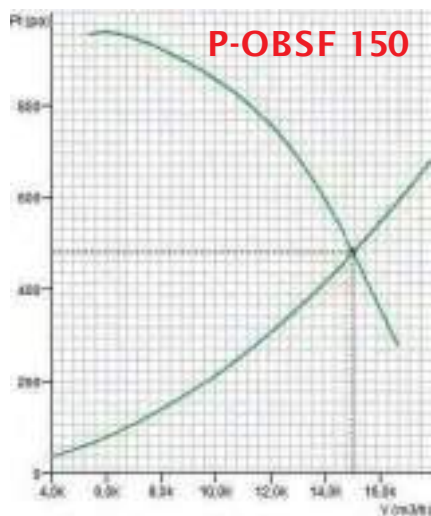
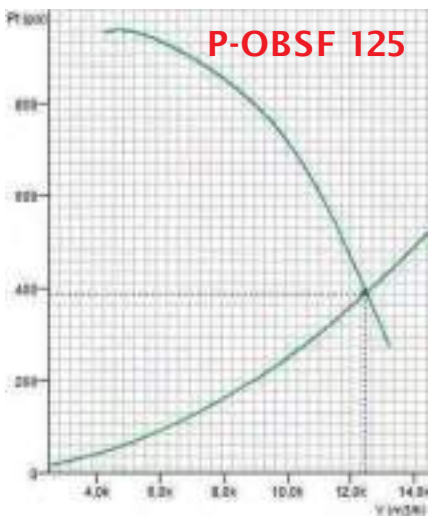
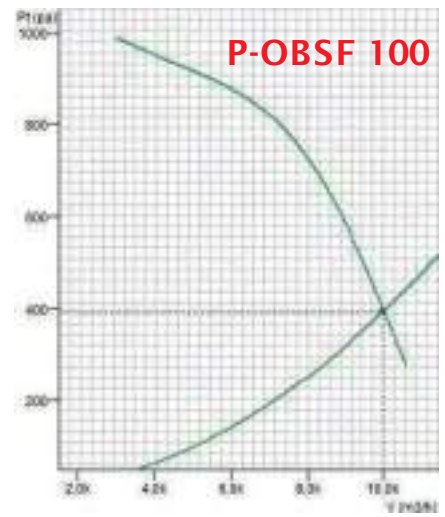
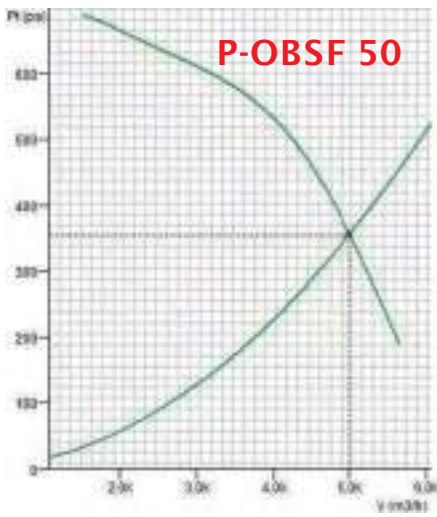

Eco Heat Recovery Unit

IGK-ECO



Utilization Areas



Description

- * Low noise level
- * G4 Filtre
- * Easy installation
- * Double Wall (Optional)
- * Centrifugal and Plug Fan(Optional)

Technical Drawing

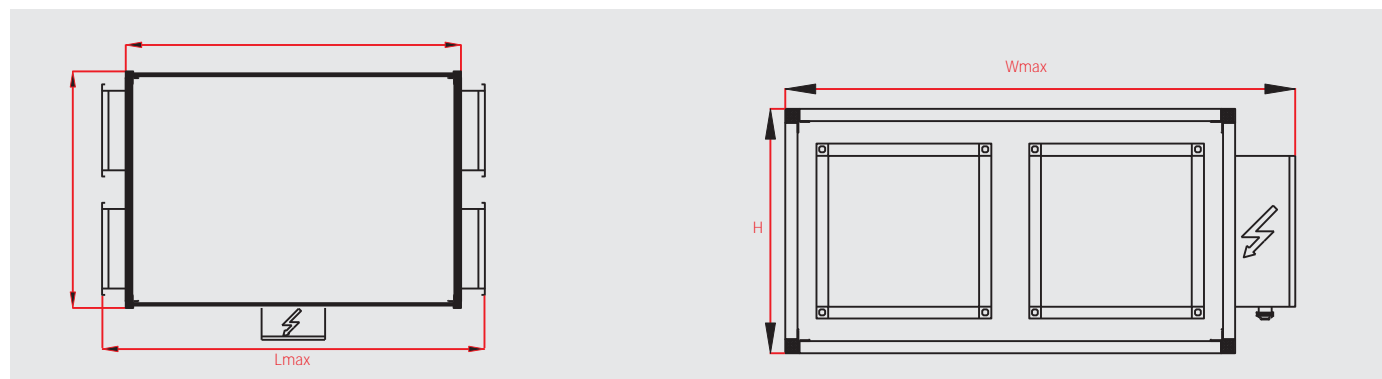

Technical Characteristics

MODELS	FLOW (m³/h)	POWE R (W)	VOLTAGE (V)	SPEED (rpm)	FREQ. (Hz)	NOIS E (dbA)	Emis-Atıs DIMENSI ONSİ (mm)	W (mm)	Wmax (mm)	DIMENSI ONS L (mm)	Lmax (mm)	H (mm)
P-IGK ECO 500	500	0,3	230	1450	50	45	250 x 250	745	845	1055	1205	405
P-IGK ECO 750	750	0,3	230	1450	50	45	250 x 250	745	845	1055	1205	405
P-IGK ECO 1000	1000	0,3	230	1450	50	45	250 x 250	755	855	1055	1205	405
P-IGK ECO 1500	1500	0,4	230	1450	50	55	250 x 250	815	915	1155	1305	485
P-IGK ECO 2000	2000	0,4	230	1450	50	55	300 x 300	815	915	1315	1465	485
P-IGK ECO 3000	3000	0,4	230	1450	50	55	400 x 400	1200	1455	1355	1505	555
P-IGK ECO 4000	4000	0,40	230	1450	50	55	450 x 450	1450	1550	1450	1600	555
P-IGK ECO 5000	5000	0,80	230	1450	50	55	500 x 500	1350	1450	1525	1675	635
P-IGK ECO 6000	6000	1,10	230	1450	50	57	500 x 500	1350	1450	1870	2020	655

Performance Curves

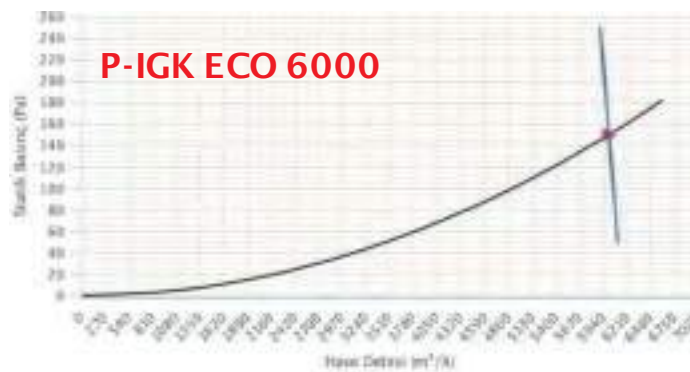
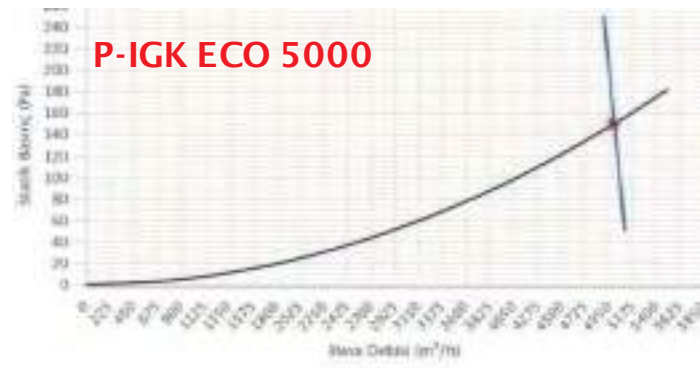
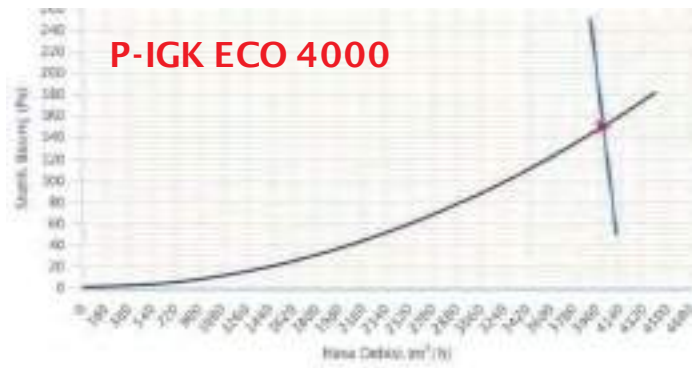
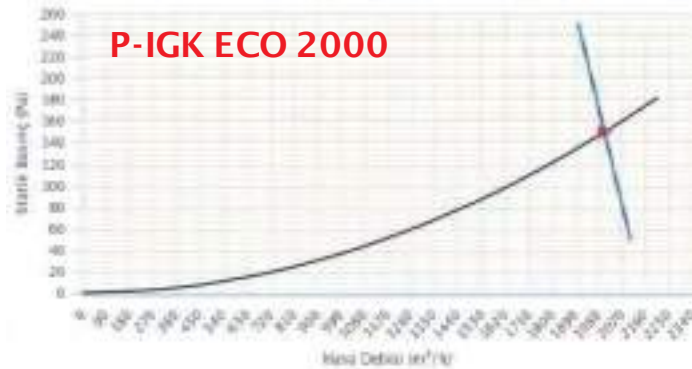
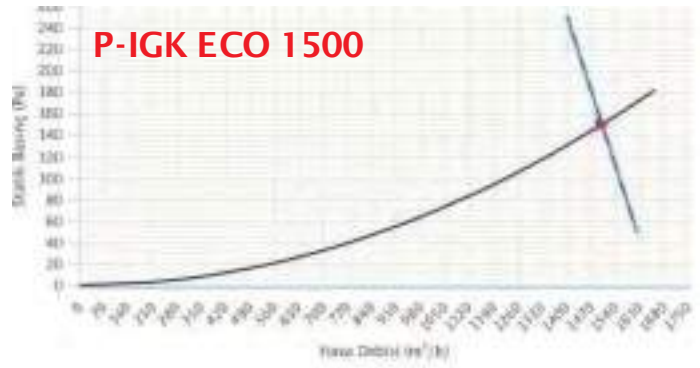
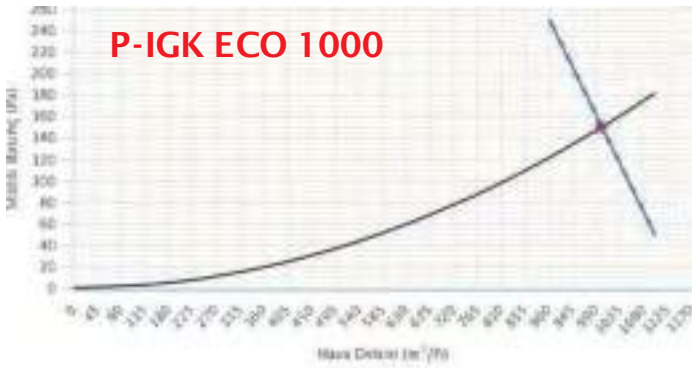
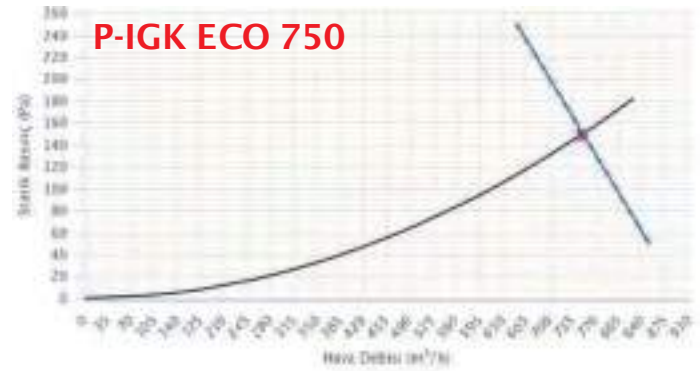
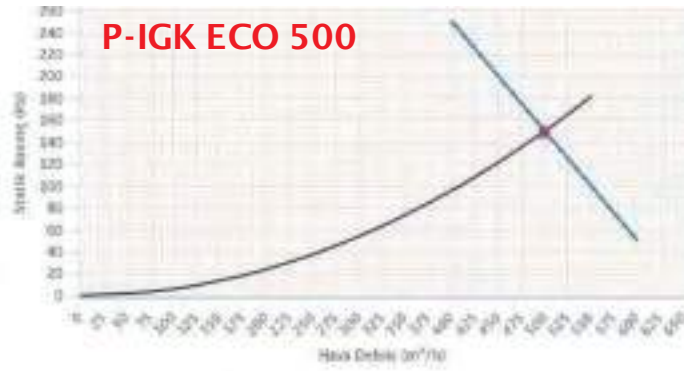

Plug Fan -Double Wall Heat Recovery Unit

IGK

point®



Utilization Areas



Description

- * Low noise level
- * G4 Filtre
- * Easy installation
- * Double Wall (Optional)
- * Centrifugal ve Plug Fan(Optional)

Technical Drawing

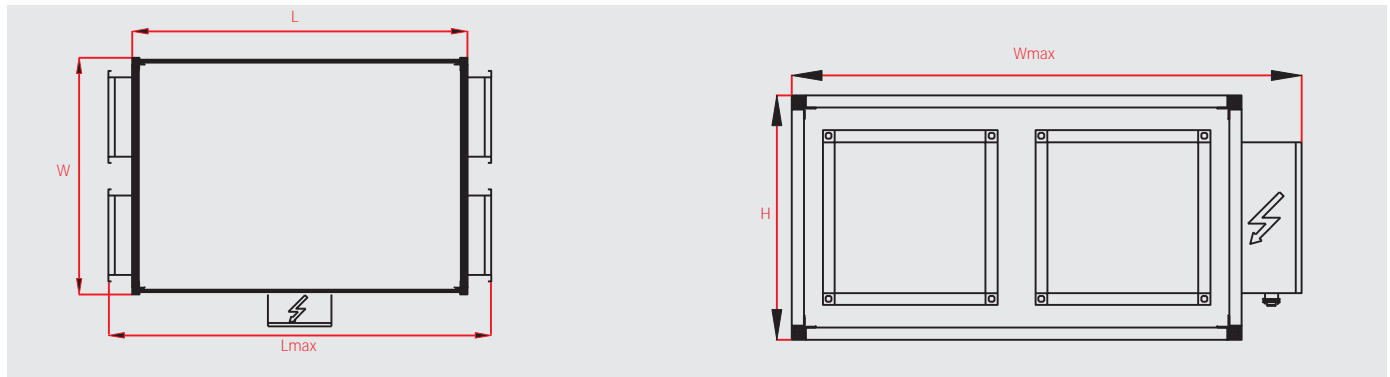

Technical Characteristics

MODELS	FLOW (m³/h)	POWER (W)	VOLTAGE (V)	SPEED (rpm)	FREQ. (Hz)	NOIS E (dbA)	Emis-Atış DIMENSI ONSİ (mm)	W (mm)	Wmax (mm)	DIMENSIONS		H (mm)
										L (mm)	Lmax (mm)	
P-IGK 500	500	0,3	230	1450	50	45	250 x 250	745	845	1055	1205	405
P-IGK 750	750	0,3	230	1450	50	45	250 x 250	745	845	1055	1205	405
P-IGK 1000	1000	0,3	230	1450	50	45	250 x 250	755	855	1055	1205	405
P-IGK 1500	1500	0,4	230	1450	50	55	250 x 250	815	915	1155	1305	485
P-IGK 2000	2000	0,4	230	1450	50	55	300 x 300	815	915	1315	1465	485
P-IGK 3000	3000	0,4	230	1450	50	55	400 x 400	1200	1455	1355	1505	555
P-IGK 4000	4000	0,40	230	1450	50	55	450 x 450	1450	1550	1450	1600	555
P-IGK 5000	5000	0,80	230	1450	50	55	500 x 500	1350	1450	1525	1675	635
P-IGK 6000	6000	1,10	230	1450	50	57	500 x 500	1350	1450	1870	2020	655

Performance Curves

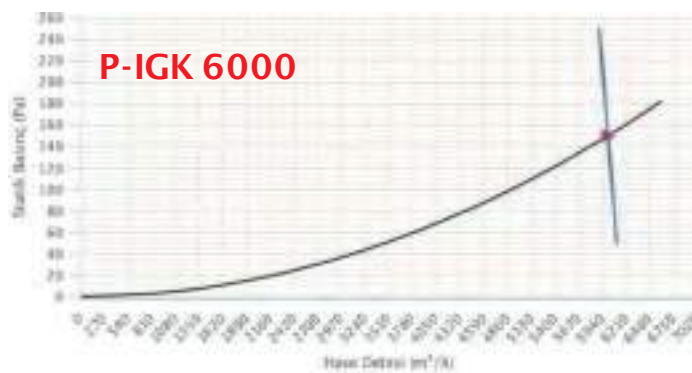
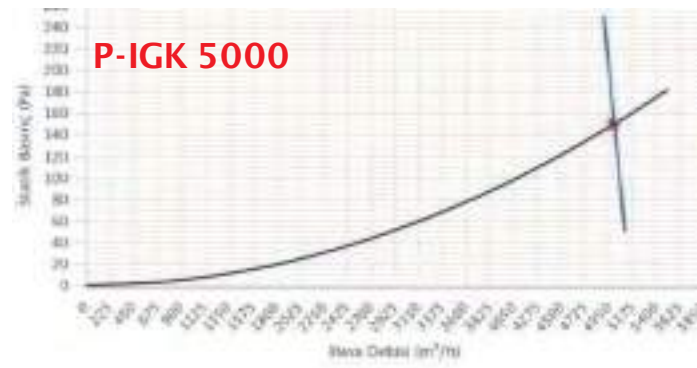
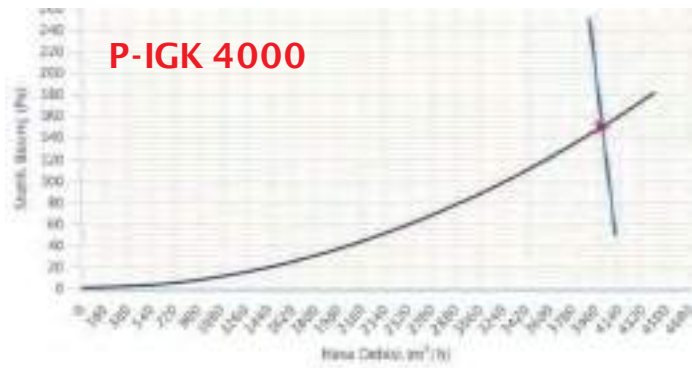
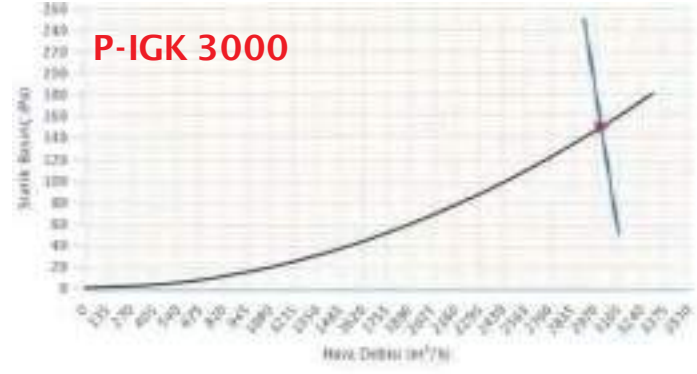
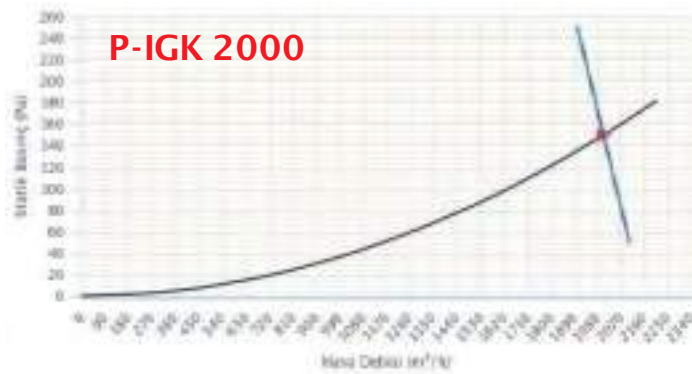
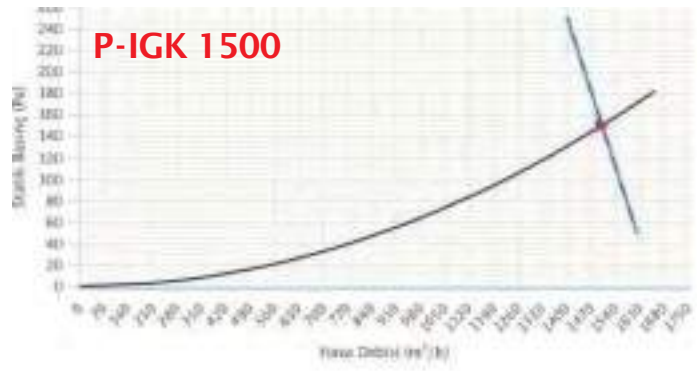
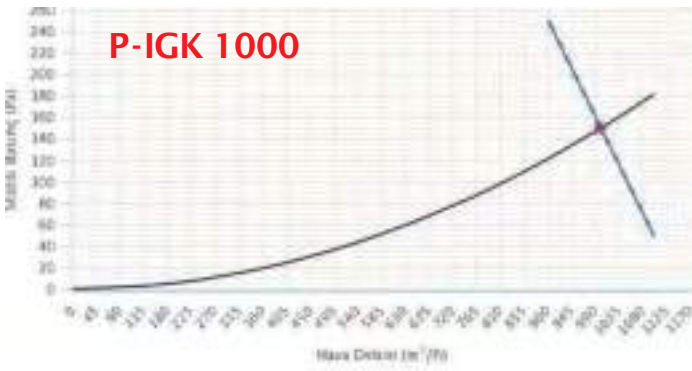
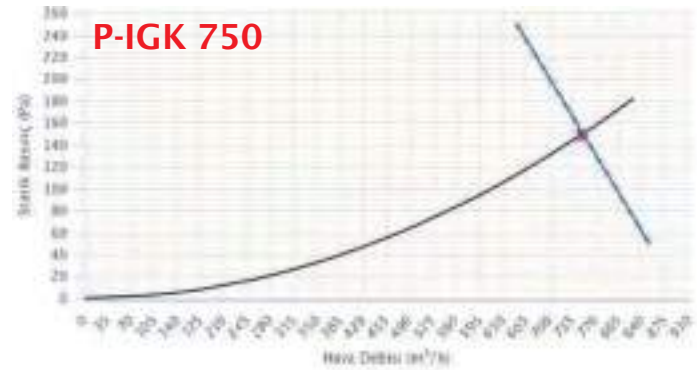
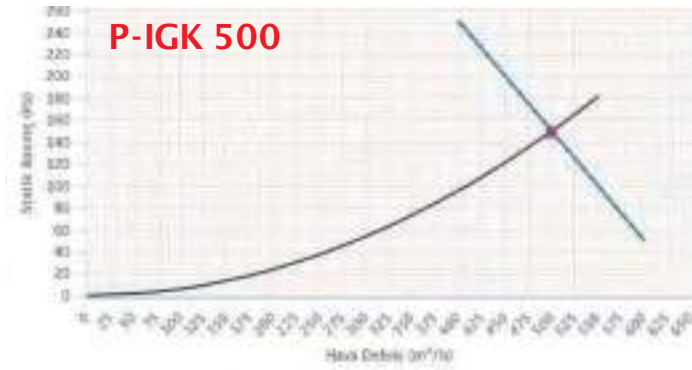

Heat Recovery Unit With heat pump

IGK-IP



point®



Utilization Areas



Description

- * Low noise level
- * DX water coil
- * Centrifugal-Plug Fan(Optional)
- * Double Wall panel
- * G4 filtre
- * Easy installation

Technical Drawing

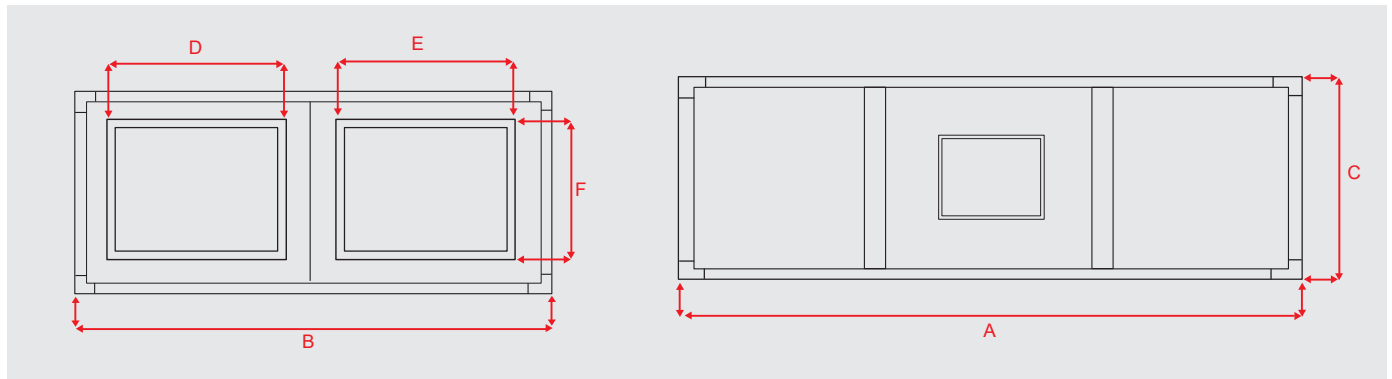

Technical Characteristics

MODELS	FLOW (m ³ /h)	POWER (kW)	VOLTAGE (V)	SPEED (rpm)	FREQ. (Hz)	NOISE (dbA)	SOĞUTMA KAPASİTESİ (kW)	ISITMA KAPASİTESİ (kW)	A (mm)	B (mm)	DIMENSIONS C (mm) D (mm)		E (mm)	F (mm)
P-IP-IGK 1000	1000	0,21*2	230	1450	50	45	5,16	8,02	1450	1100	460	300	300	300
P-IP-IGK 2000	2000	0,40*2	230	1450	50	55	9,68	13,74	1550	1295	585	450	450	400
P-IP-IGK 3000	3000	0,80*2	230	1450	50	55	14,19	21,12	1695	1495	635	500	500	550
P-IP-IGK 4000	4000	0,37*2	230	1450	50	55	18,93	29,26	1835	1700	665	600	600	550

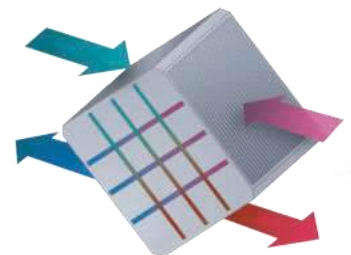
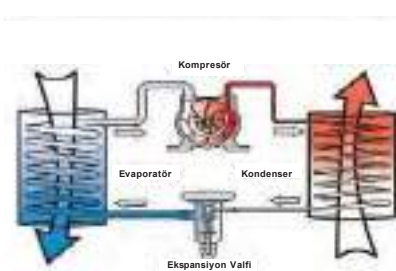

Performance Curves

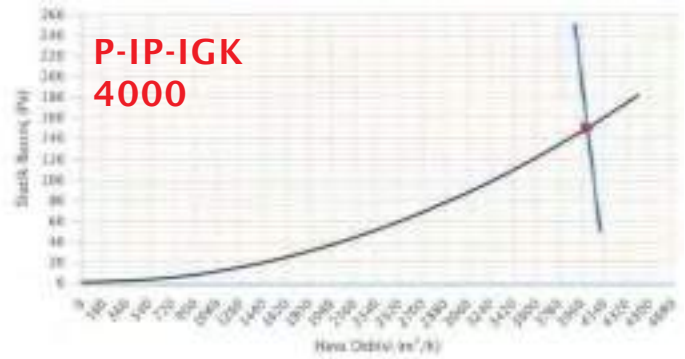
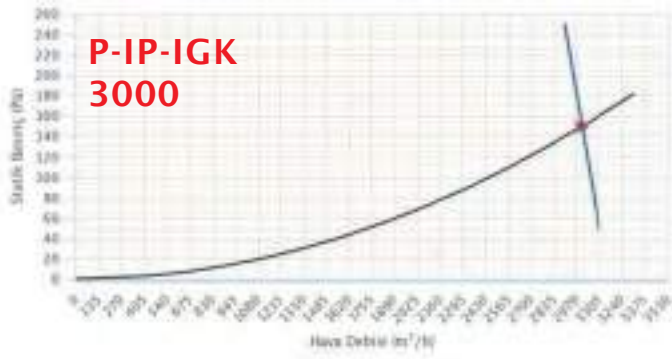
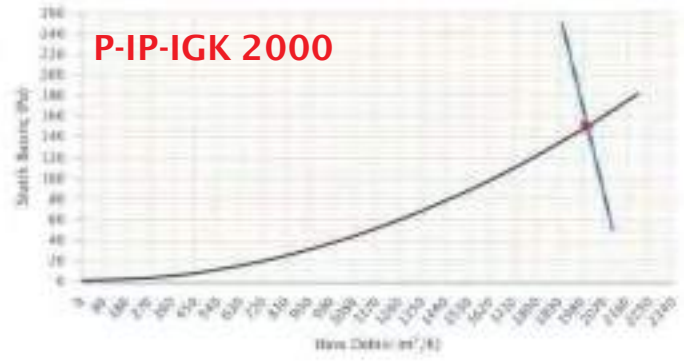
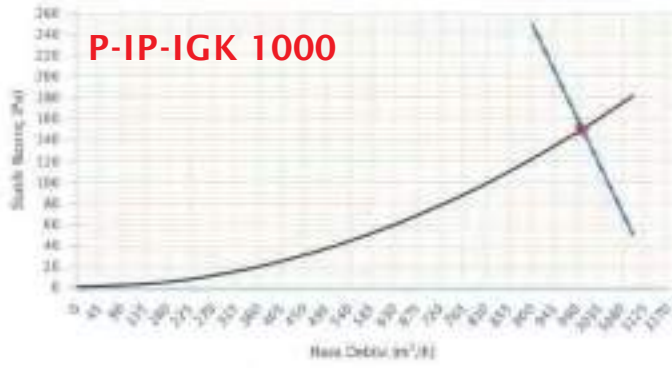

Axial Pressurisation Fan

BF



Utilization Areas



Description

- * Galvanised Steel Sheet panels
- * Easy Installation
- * Electrostatic Powder Coating
- * Opposite flange(Optional)
- * Plastic propeller
- * Protective wire mesh (Optional)
- * Special propeller design
- * Sealed connect. box cover

Technical

MODELS	FLOW (m³/h)	POWER (kW)	VOLTAGE (V)	CURRENT (A)	SPEED (rpm)	FREQ. (Hz)	NOISE (dbA)	D (mm)	DIMENSIONS		Dmax (mm)
									Hmax (mm)	Lmax (mm)	
P-BF 315 A	2350	0.18	380	0.6	1500	50	38	315	410	300	375
P-BF 315 B	11000	0.55	380	1.3	3000	50	41	315	410	300	375
P-BF 355 A	4500	0.18	380	0.60	1500	50	44	355	455	300	415
P-BF 355 B	13200	1.1	380	2.30	3000	50	47	355	455	300	415
P-BF 400 A	3100	0.25	380	0.80	1500	50	50	400	500	400	460
P-BF 400 B	17500	1.5	380	3.30	3000	50	53	400	500	400	460
P-BF 450 A	6100	0.37	380	1.15	1500	50	56	450	550	400	510
P-BF 450 B	19800	3.00	380	5.90	3000	50	59	450	550	400	510
P-BF 500 A	5000	0.55	380	1.60	1500	50	62	500	600	400	560
P-BF 500 B	22000	3.00	380	5.90	3000	50	65	500	600	400	560
P-BF 560 A	10000	0.55	380	1.6	1500	50	68	560	660	400	620
P-BF 630 A	6600	0.75	380	2	1500	50	71	630	730	500	690
P-BF 630 B	14100	1.5	380	3.5	1500	50	74	630	730	500	690
P-BF 630 C	8000	2.2	380	5	1500	50	77	630	730	500	690
P-BF 630 D	17800	3	380	6.6	1500	50	80	630	730	500	690
P-BF 710 A	27000	4	380	8.4	1500	50	83	710	810	500	770
P-BF 800 A	35000	4	380	8.4	1500	50	86	800	900	560	860
P-BF 800 B	37000	5.5	380	11.2	1500	50	89	800	900	560	860
P-BF 800 C	42000	7.5	380	15.4	1500	50	92	800	900	560	860
P-BF 900 A	44000	5.5	380	11.2	1500	50	95	900	1000	630	960
P-BF 900 B	47000	7.5	380	15.4	1500	50	98	900	1000	630	960
P-BF 1000 A	52000	5.5	380	11.2	1500	50	101	1000	1100	630	1060
P-BF 1000 B	58000	7.5	380	15.4	1500	50	104	1000	1100	630	1060
P-BF 1000 C	65000	11	380	21.3	1500	50	107	1000	1100	630	1060
P-BF 1250 A	73000	11	380	21.3	1500	50	110	1250	1350	900	1310
P-BF 1250 B	80000	15	380	29.8	1500	50	113	1250	1350	900	1310
P-BF 1250 C	105000	22	380	42.5	1500	50	116	1250	1350	900	1310
P-BF 1250 D	120000	30	380	55	1500	50	119	1250	1350	900	1310

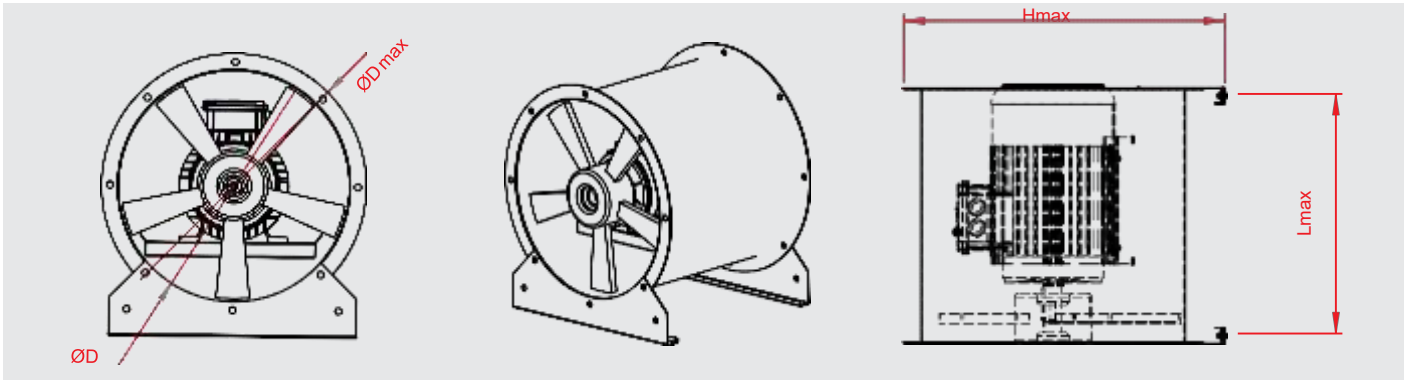

Performance Curves

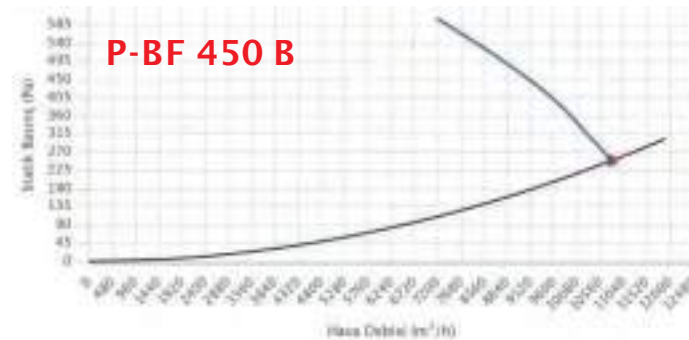
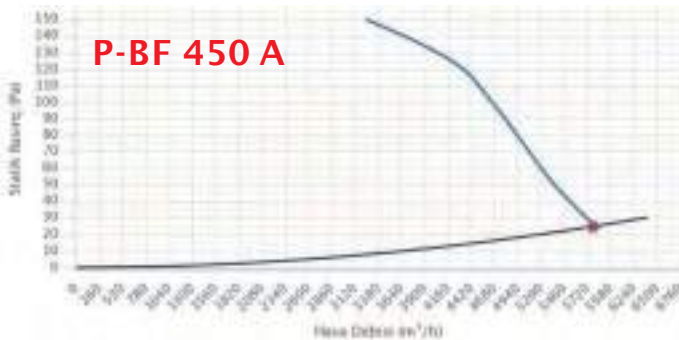
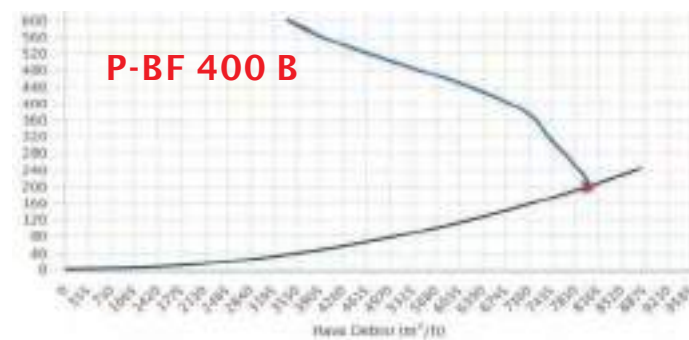
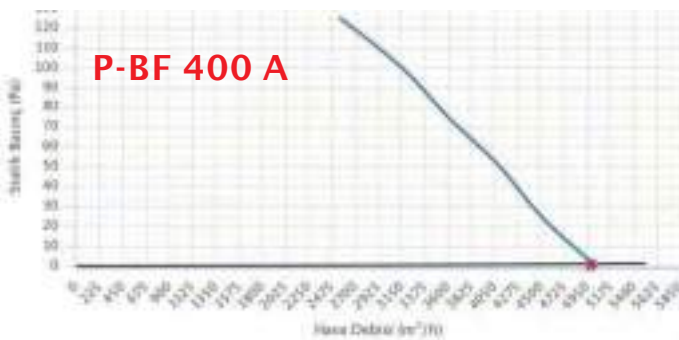
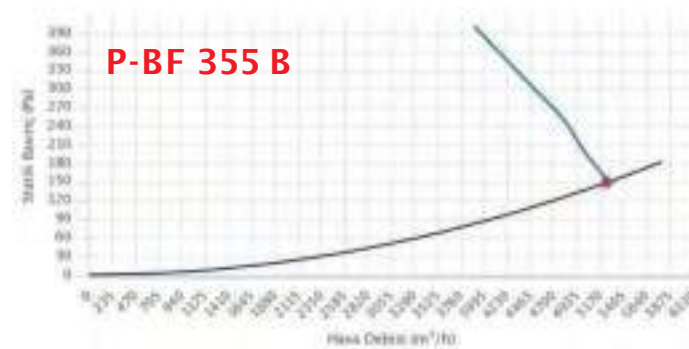
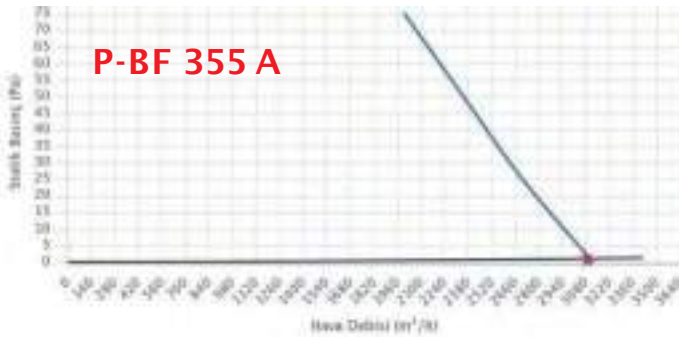
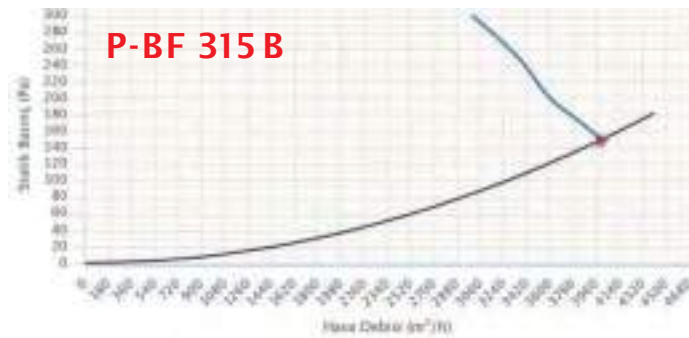
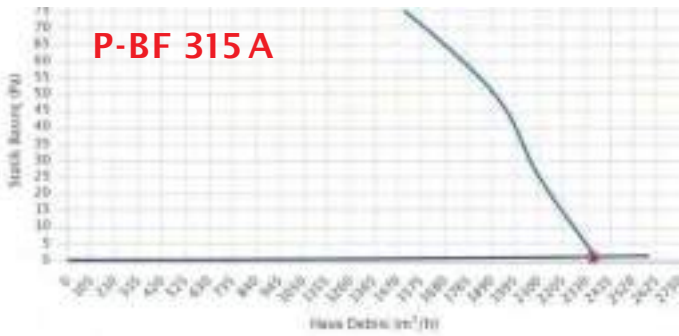

Performance Curves

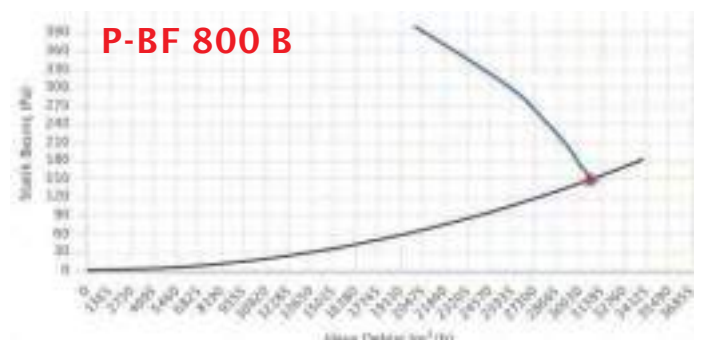
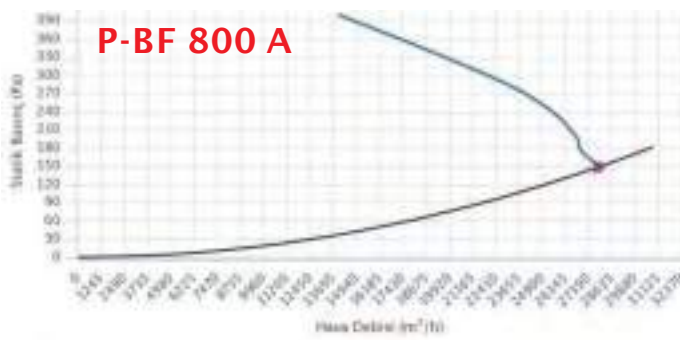
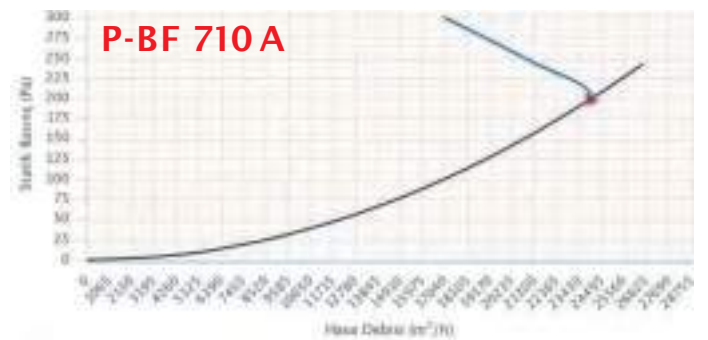
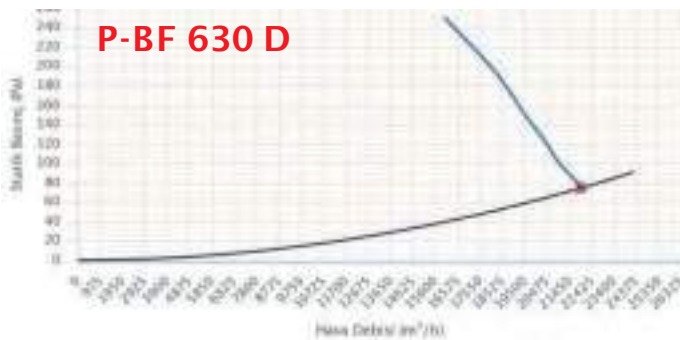
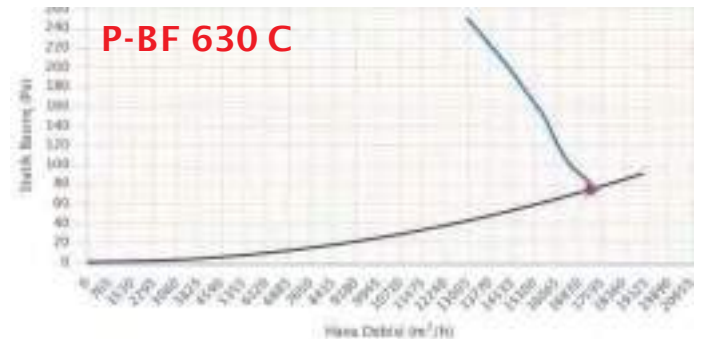
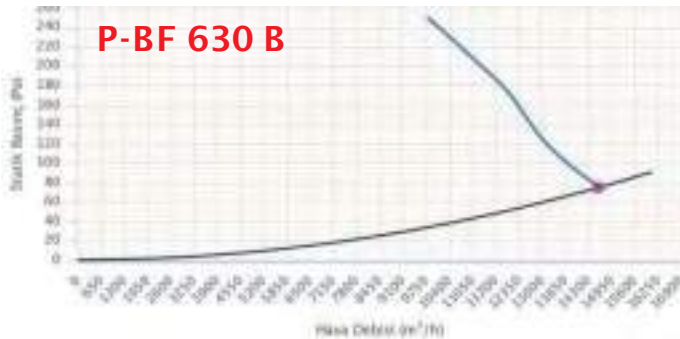
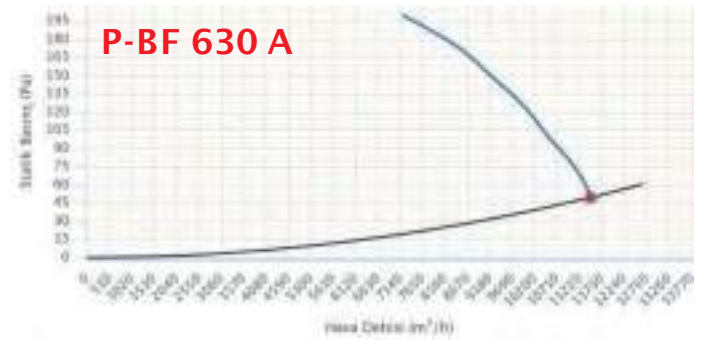
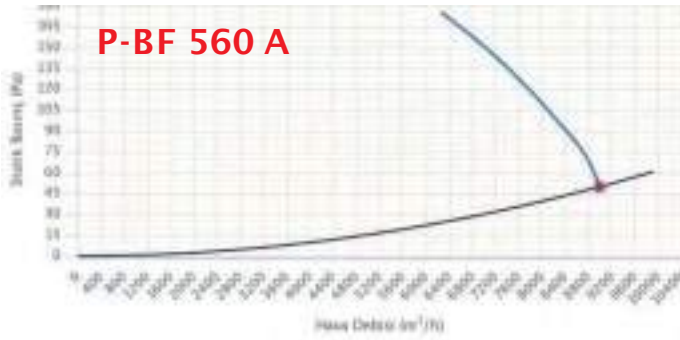
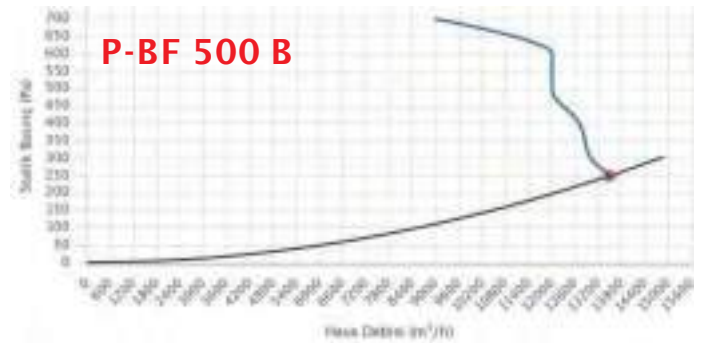
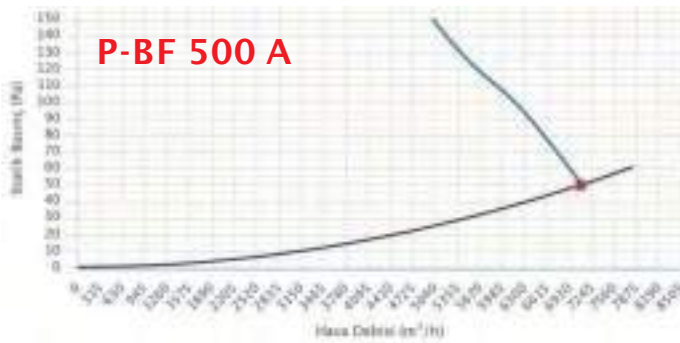

Performance Curves

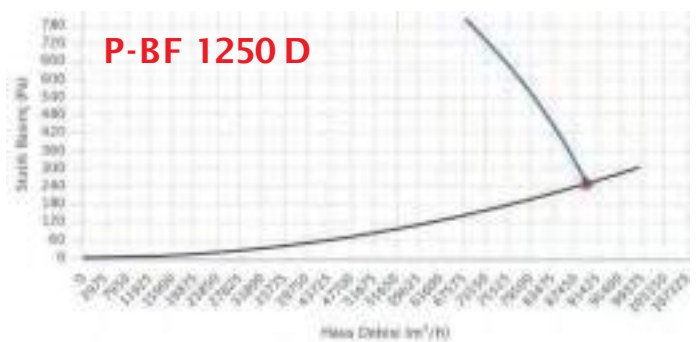
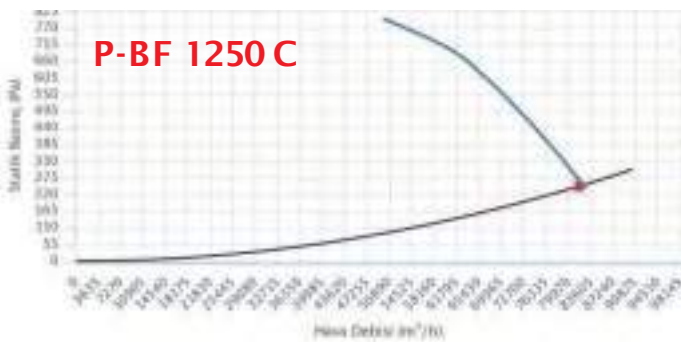
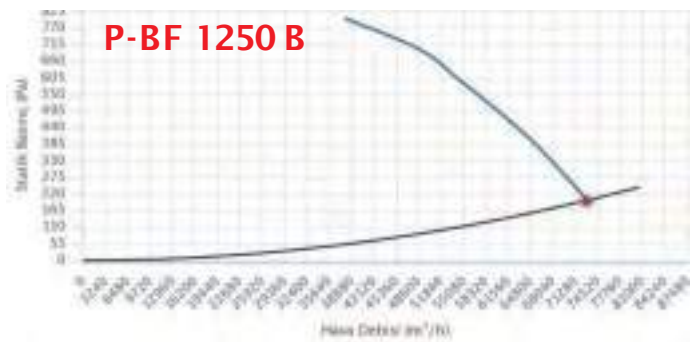
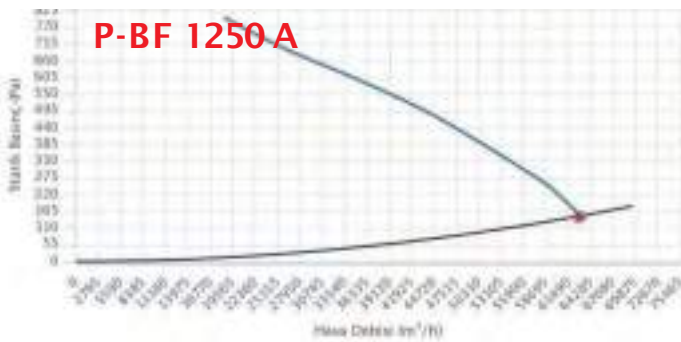
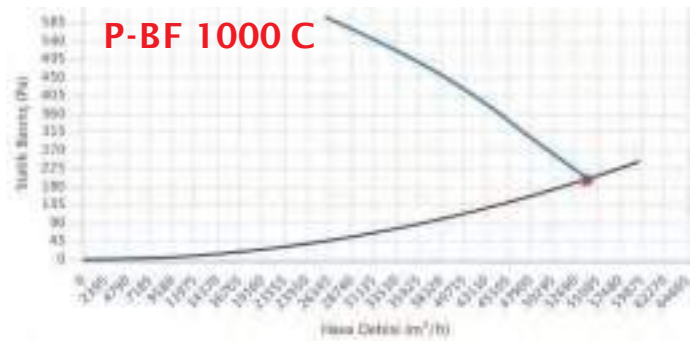
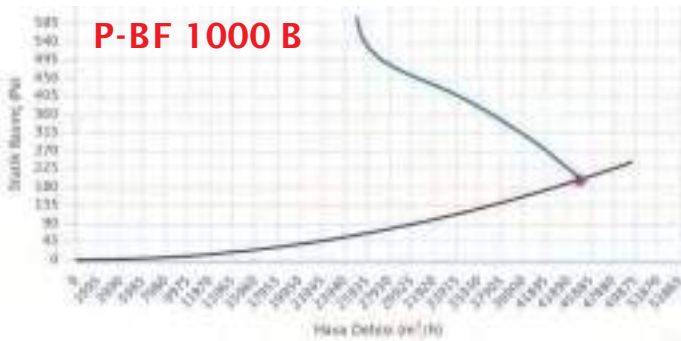
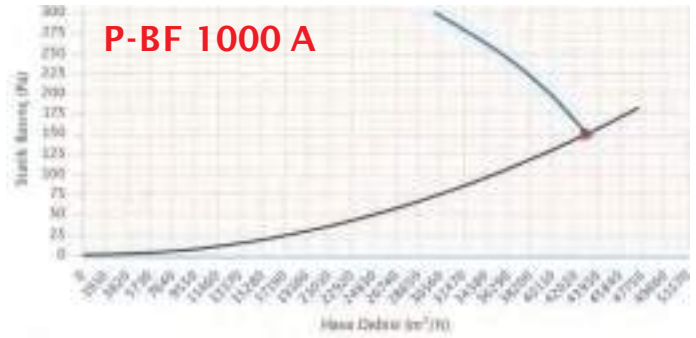
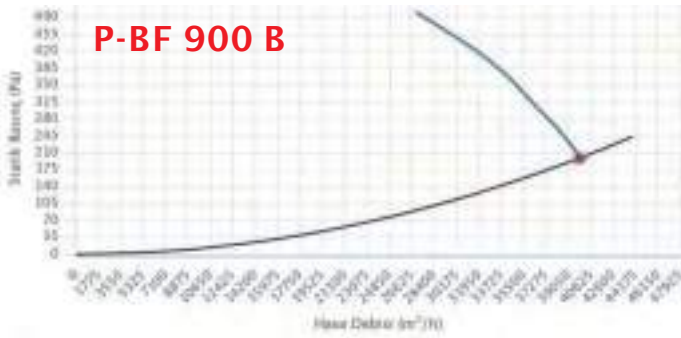
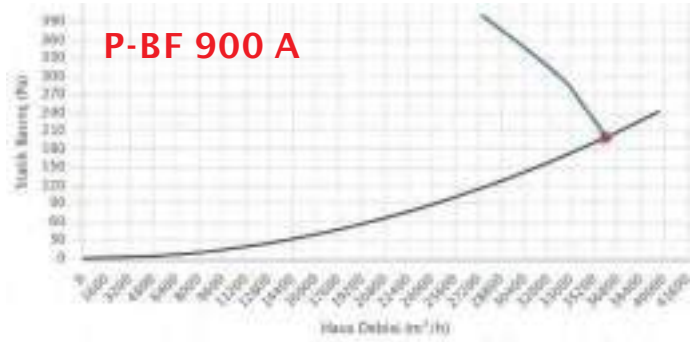
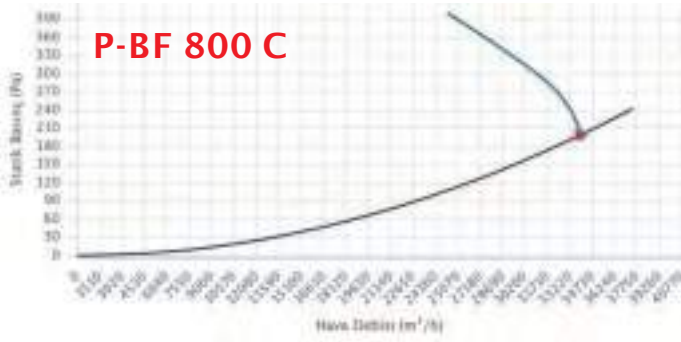

Roof Type Axial Pressurisation Fan

CAF.



point®



Utilization Areas



Description

- * Waterproof
- * Protective wire mesh
- * Galvanised Steel Sheet Case
- * Low noise level
- * Electrostatic Powder Coating
- * IP55 protection
- * Easy Handling
- * Ease of application

Technical Characteristics

MODELS	FLOW (m³/h)	POWER (kW)	VOLTAGE (V)	CURRENT (A)	SPEED (rpm)	FREQ. (Hz)	NOISE (dbA)	B (mm)	DIMENSIONS Hmax (mm)	W (mm)
P-CAF 315 A	2350	0,18	380	0,58	1450	50	38	415	640	515
P-CAF 355 A	3100	0,18	380	0,58	1450	50	41	455	640	555
P-CAF 400 A	5000	0,25	380	0,81	1450	50	44	500	640	600
P-CAF 450 A	6600	0,37	380	1,20	1450	50	47	550	690	650
P-CAF 500 A	8000	0,55	380	1,60	1450	50	50	600	690	700
P-CAF 560 A	11000	0,55	380	1,60	1450	50	53	660	770	760
P-CAF 630 A	13200	0,75	380	2,10	1450	50	56	730	770	830
P-CAF 630 B	17500	1,50	380	3,60	1450	50	59	730	770	830
P-CAF 630 C	19800	2,20	380	5,30	1450	50	62	730	770	830
P-CAF 630 D	22000	3,00	380	6,60	1450	50	65	730	770	830
P-CAF 315 B	4500	0,55	380	1,30	2850	50	68	415	640	515
P-CAF 355 B	6100	1,10	380	2,50	2850	50	71	455	640	555
P-CAF 400 B	10000	1,50	380	3,45	2850	50	74	500	640	600
P-CAF 450 B	14100	3,00	380	6,50	2850	50	77	550	690	650
P-CAF 500 B	17800	3,00	380	6,50	2850	50	80	600	690	700
P-CAF 710 A	27000	4,00	380	8,70	1450	50	83	810	890	910
P-CAF 800 A	35000	4,00	380	8,70	1450	50	86	900	970	1000
P-CAF 800 B	37000	5,50	380	11,80	1450	50	89	900	970	1000
P-CAF 800 C	42000	7,50	380	15,80	1450	50	92	900	970	1000
P-CAF 900 A	44000	5,50	380	11,80	1450	50	95	810	890	910
P-CAF 900 B	47000	7,50	380	15,80	1450	50	98	810	890	910
P-CAF 1000 A	52000	5,50	380	11,80	1450	50	101	1100	1100	1200
P-CAF 1000 B	58000	7,50	380	15,80	1450	50	104	1100	1100	1200
P-CAF 1000 C	65000	11,00	380	22,50	1450	50	107	1100	1100	1200
P-CAF 1250 A	73000	11,00	380	22,50	1450	50	110	1350	1210	1450
P-CAF 1250 B	80000	15,00	380	30,00	1450	50	113	1350	1210	1450
P-CAF 1250 C	105000	22,00	380	42,00	1450	50	116	1350	1210	1450
P-CAF 1250 D	120000	30,00	380	57,00	1450	50	119	1350	1210	1450

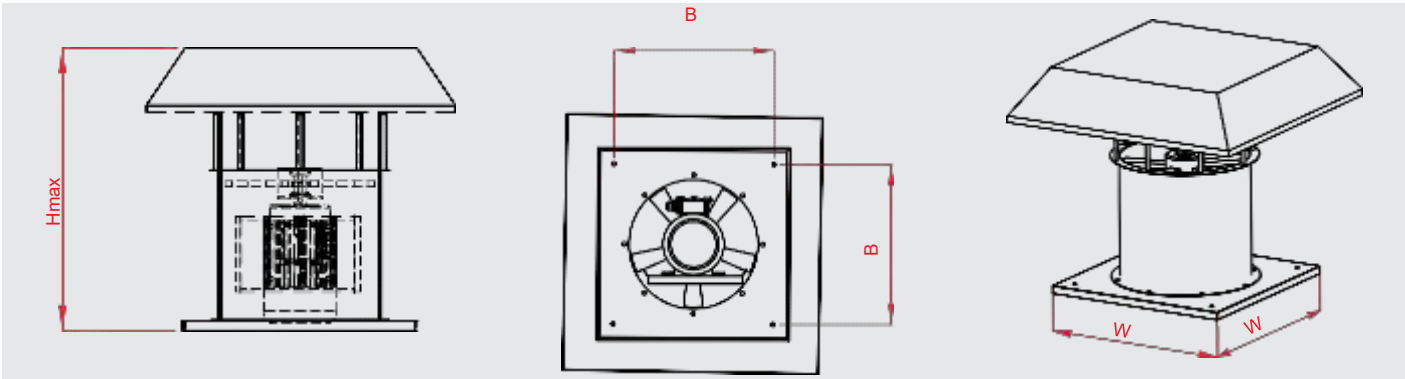

Performance Curves

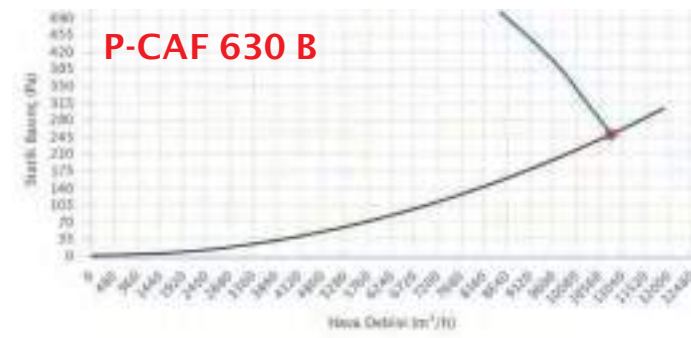
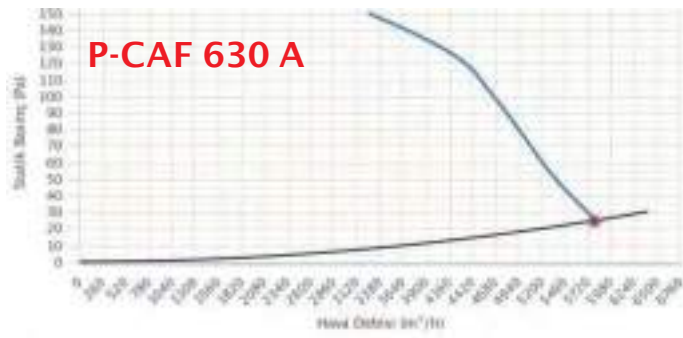
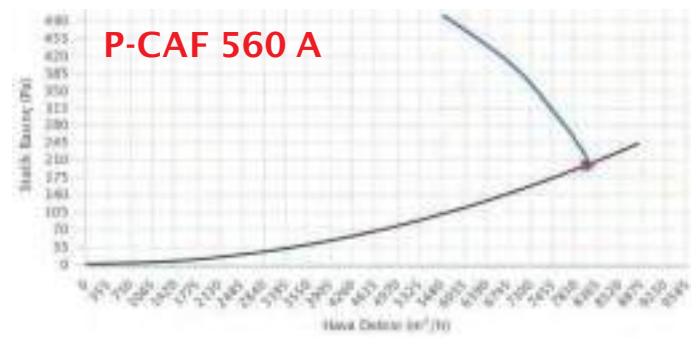
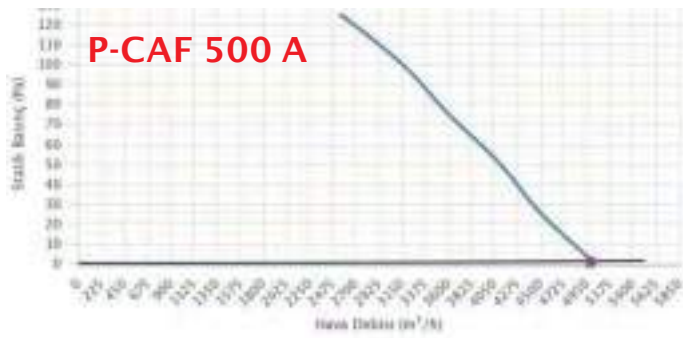
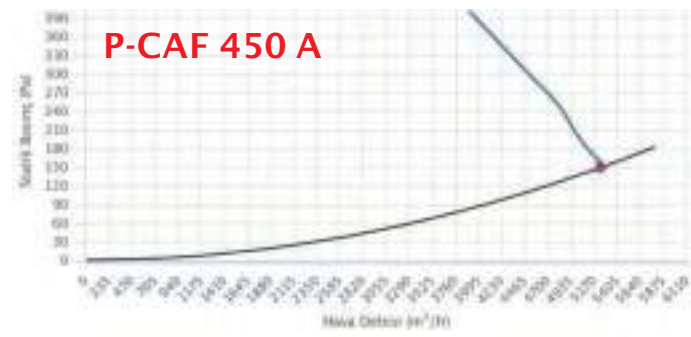
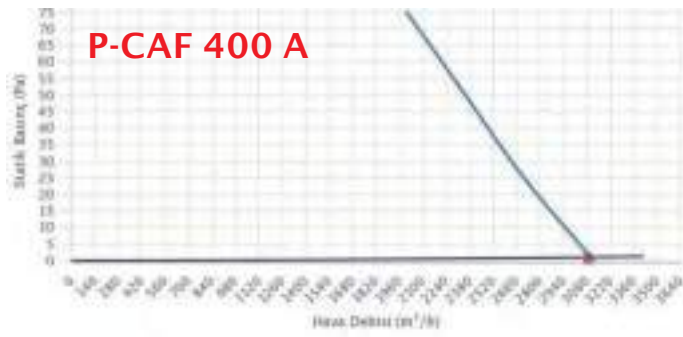
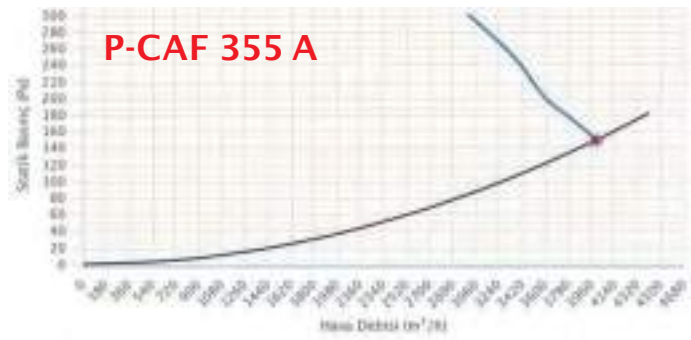
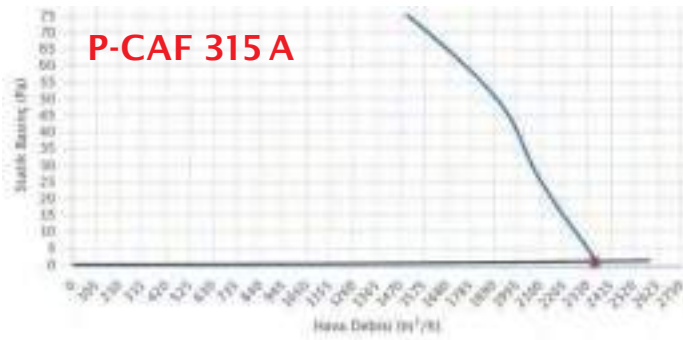

Performance Curves

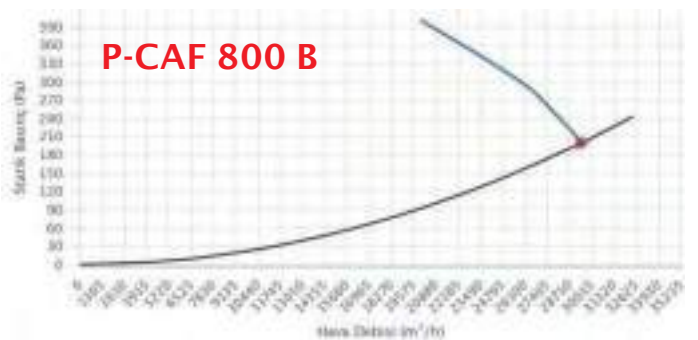
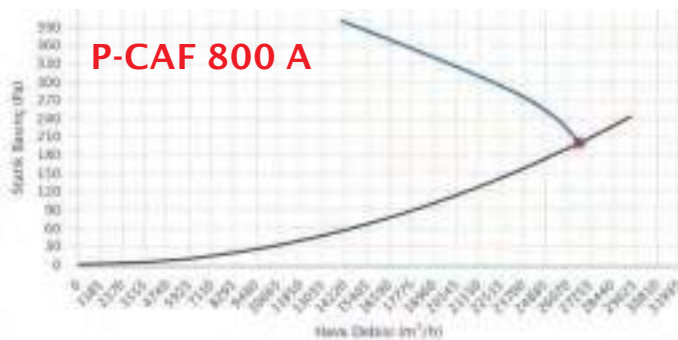
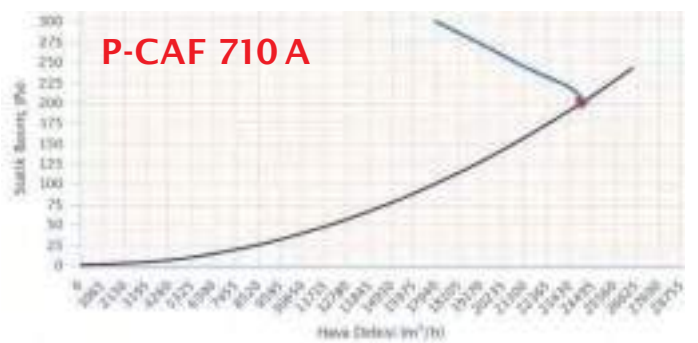
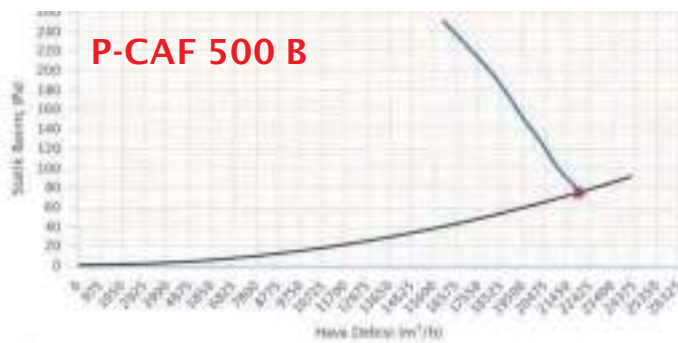
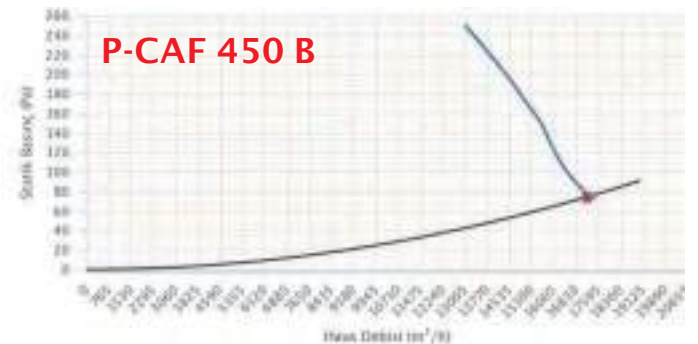
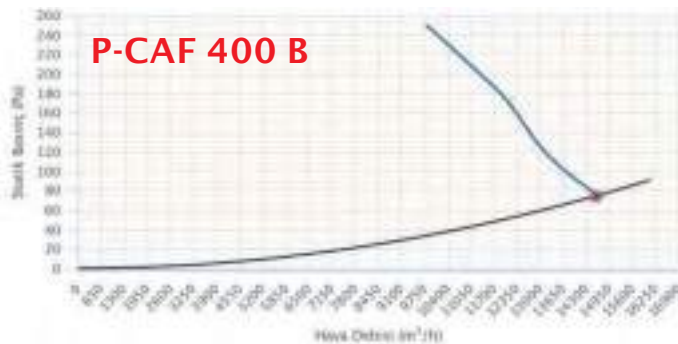
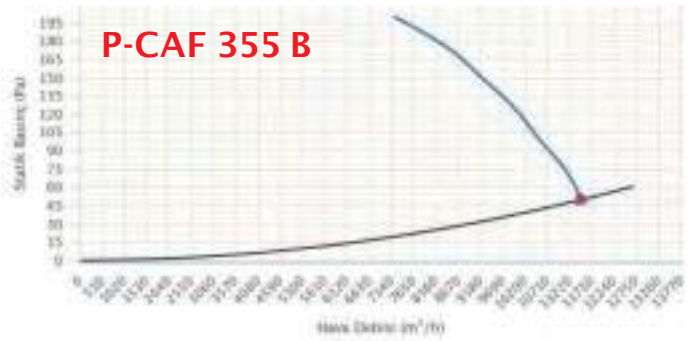
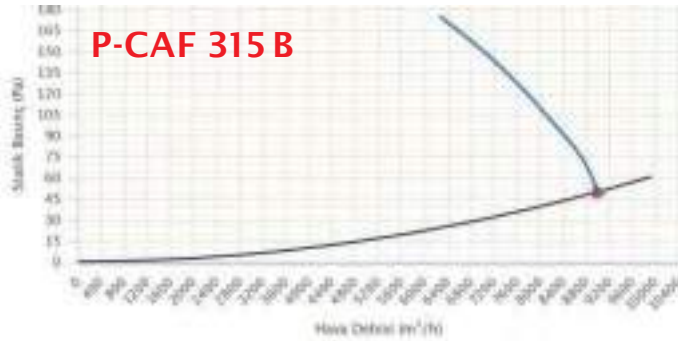
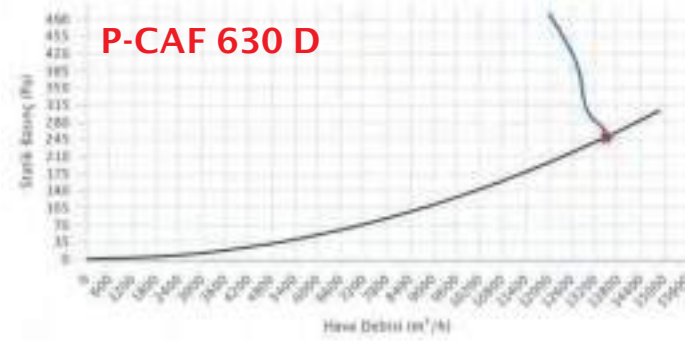
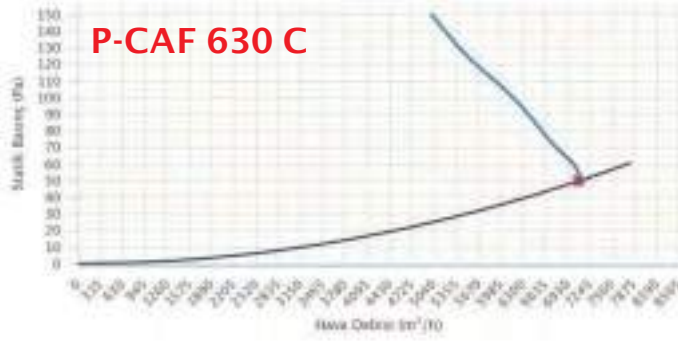

Performance Curves

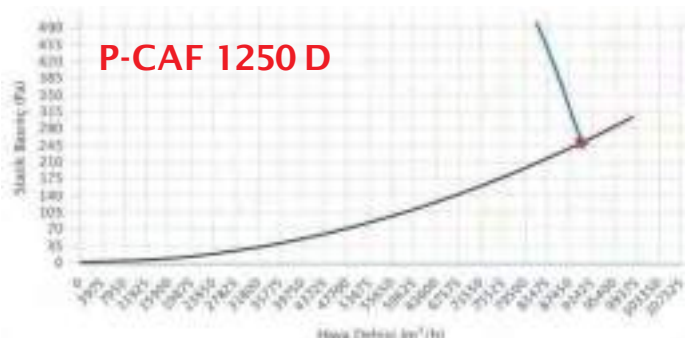
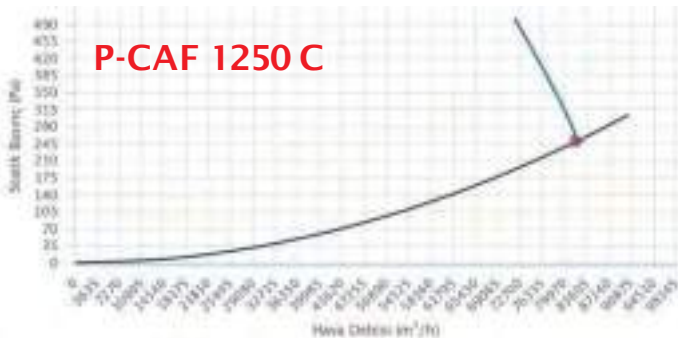
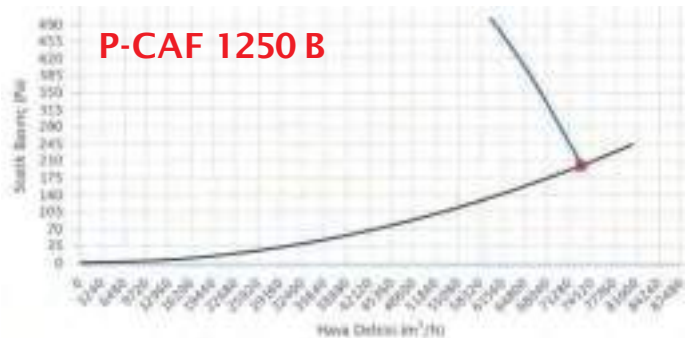
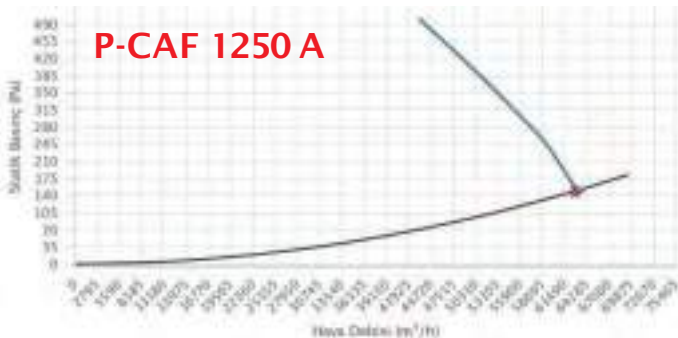
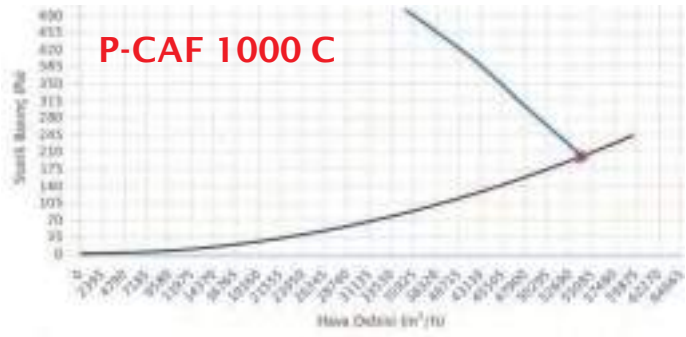
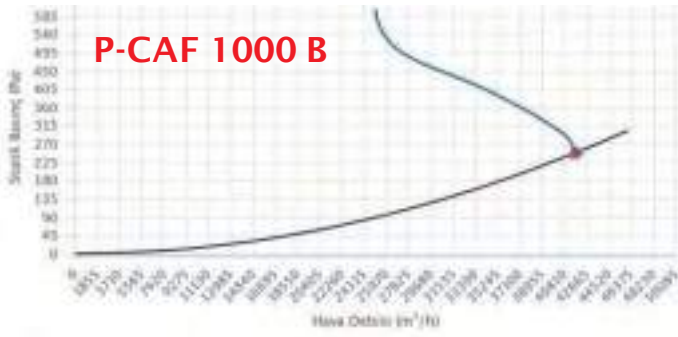
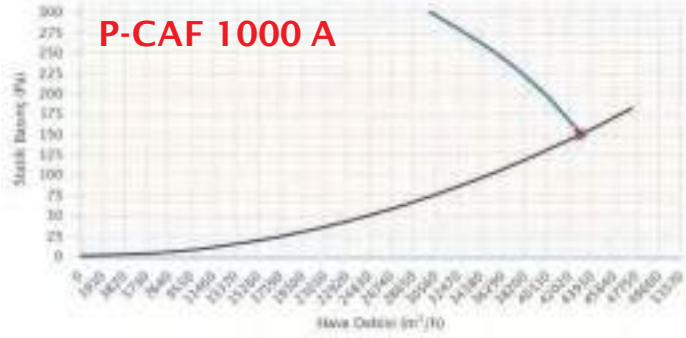
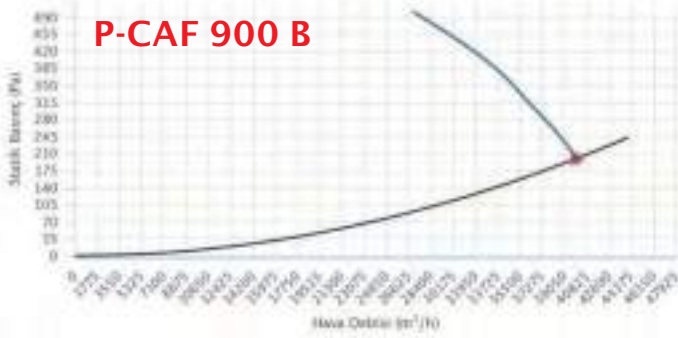
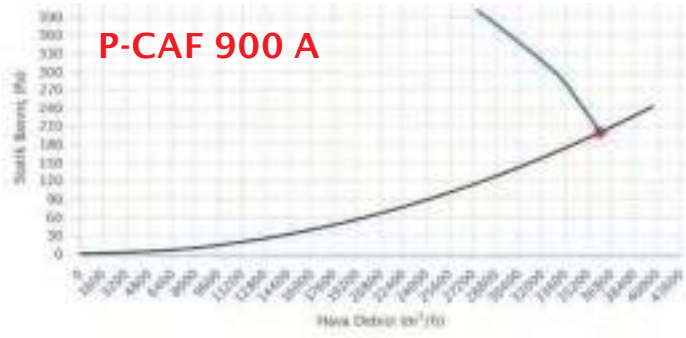
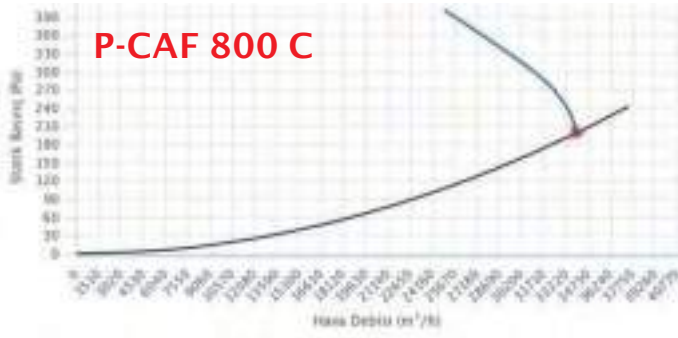

Cabinet/Cell Type Axial Pressurisation Fan

HAF



Utilization Areas



Description

- * Special propeller design
- * Plastic propeller
- * Internal silencer
- * Double wall panels
- * Aluminum profiles
- * IP55 protection
- * Low noise level
- * Easy maintenance

Technical Characteristics

MODELS	FLOW (m³/h)	POWER (kW)	VOLTAGE (V)	CURRENT (A)	SPEED (rpm)	FREQ. (Hz)	NOISE (dbA)	H (mm)	DIMENSIONS		L (mm)
									W (mm)	Hmax (mm)	
P-HAF 315 A	2350	0,18	380	0,58	1450	50	38	595	595	695	460
P-HAF 355 A	3100	0,18	380	0,58	1450	50	41	635	635	735	460
P-HAF 400 A	5000	0,25	380	0,81	1450	50	44	680	680	780	460
P-HAF 450 A	6600	0,37	380	1,20	1450	50	47	730	730	830	510
P-HAF 500 A	8000	0,55	380	1,60	1450	50	50	780	780	880	510
P-HAF 560 A	11000	0,55	380	1,60	1450	50	53	840	840	940	590
P-HAF 630 A	13200	0,75	380	2,10	1450	50	56	910	910	1010	590
P-HAF 630 B	17500	1,50	380	3,60	1450	50	59	910	910	1010	590
P-HAF 630 C	19800	2,20	380	5,30	1450	50	62	910	910	1010	590
P-HAF 630 D	22000	3,00	380	6,60	1450	50	65	910	910	1010	590
P-HAF 315 B	4500	0,55	380	1,30	2850	50	68	595	595	695	460
P-HAF 355 B	6100	1,10	380	2,50	2850	50	71	635	635	735	460
P-HAF 400 B	10000	1,50	380	3,45	2850	50	74	680	680	780	460
P-HAF 450 B	14100	3,00	380	6,50	2850	50	77	730	730	830	510
P-HAF 500 B	17800	3,00	380	6,50	2850	50	80	780	780	880	510
P-HAF 710 A	27000	4,00	380	8,70	1450	50	83	990	990	1090	610
P-HAF 800 A	35000	4,00	380	8,70	1450	50	86	1080	1080	1180	710
P-HAF 800 B	37000	5,50	380	11,80	1450	50	89	1080	1080	1180	710
P-HAF 800 C	42000	7,50	380	15,80	1450	50	92	1080	1080	1180	710
P-HAF 900 A	44000	5,50	380	11,80	1450	50	95	1180	1180	1280	710
P-HAF 900 B	47000	7,50	380	15,80	1450	50	98	1180	1180	1280	710
P-HAF 1000 A	52000	5,50	380	11,80	1450	50	101	1280	1280	1380	825
P-HAF 1000 B	58000	7,50	380	15,80	1450	50	104	1280	1280	1380	825
P-HAF 1000 C	65000	11,00	380	22,50	1450	50	107	1280	1280	1380	825
P-HAF 1250 A	73000	11,00	380	22,50	1450	50	110	1530	1530	1630	930
P-HAF 1250 B	80000	15,00	380	30,00	1450	50	113	1530	1530	1630	930
P-HAF 1250 C	105000	22,00	380	42,00	1450	50	116	1530	1530	1630	930
P-HAF 1250 D	120000	30,00	380	57,00	1450	50	119	1530	1530	1630	930

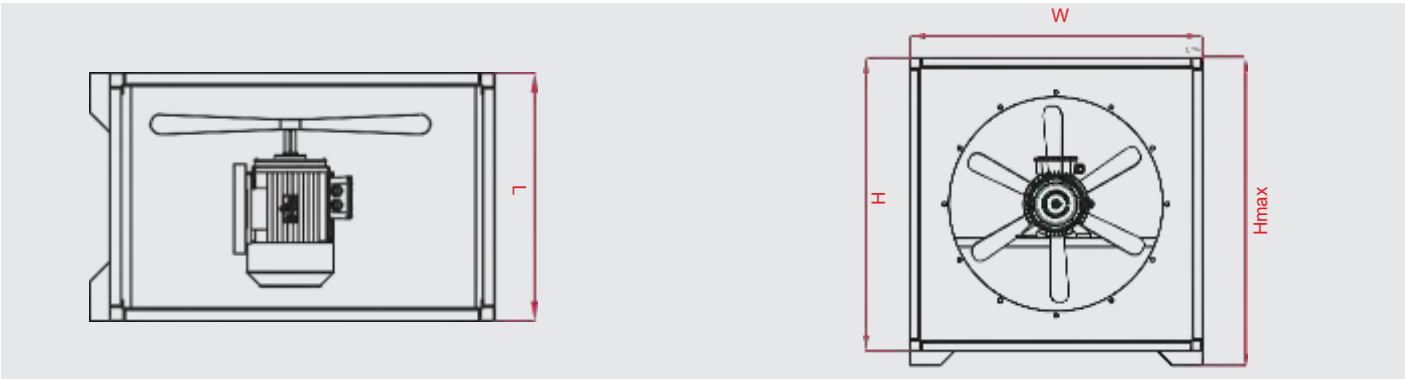

Performance Curves

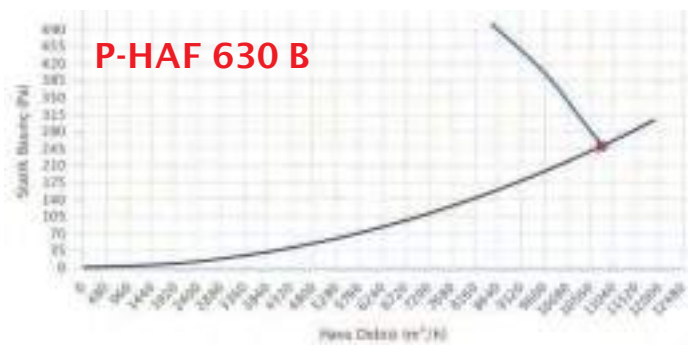
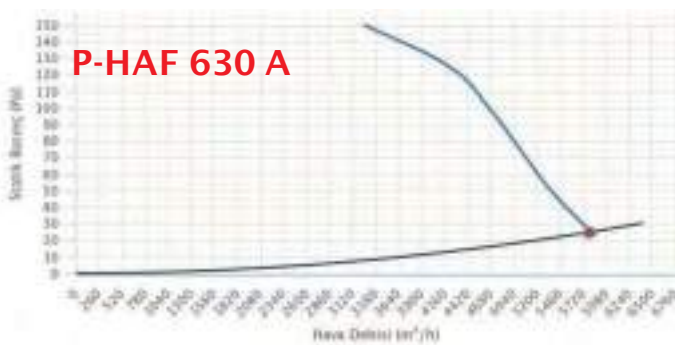
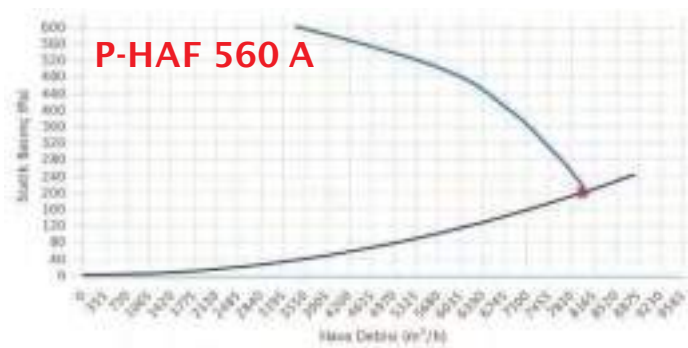
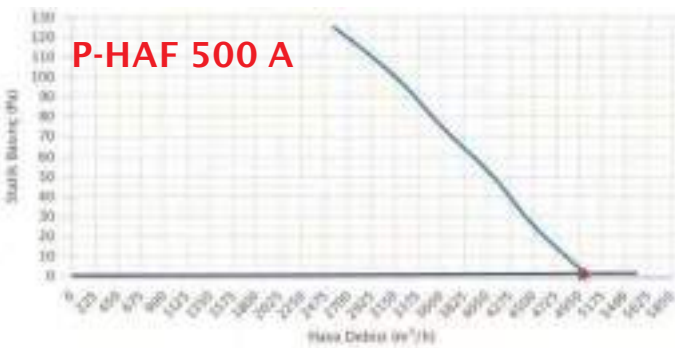
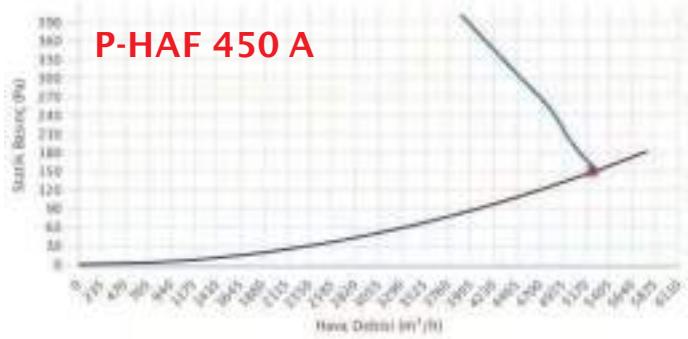
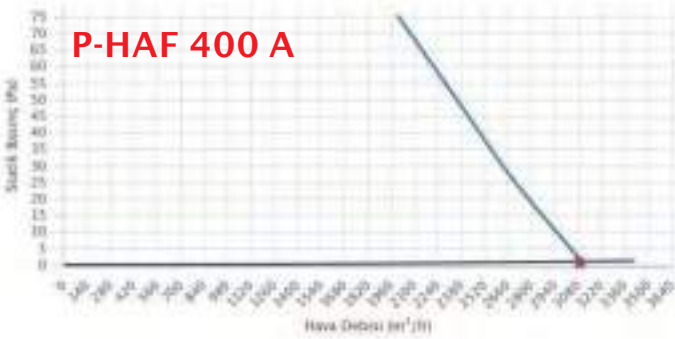
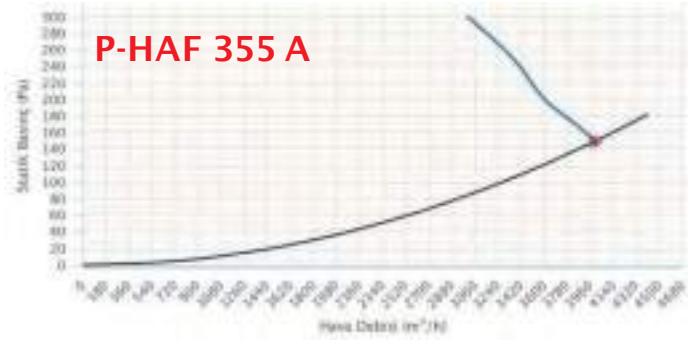
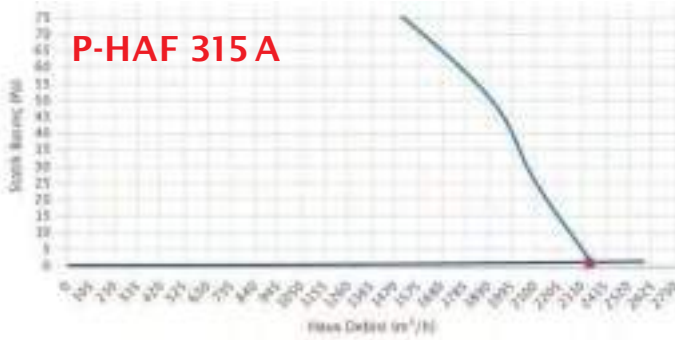

Performance Curves

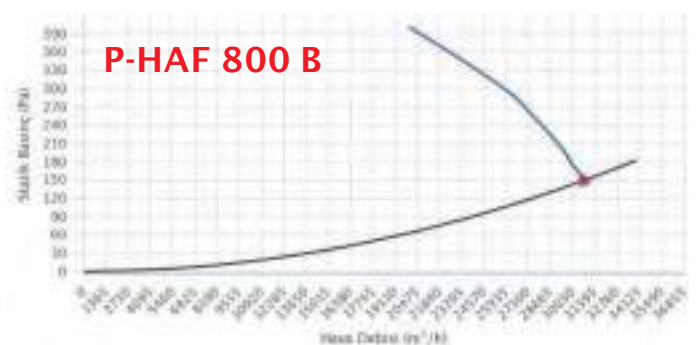
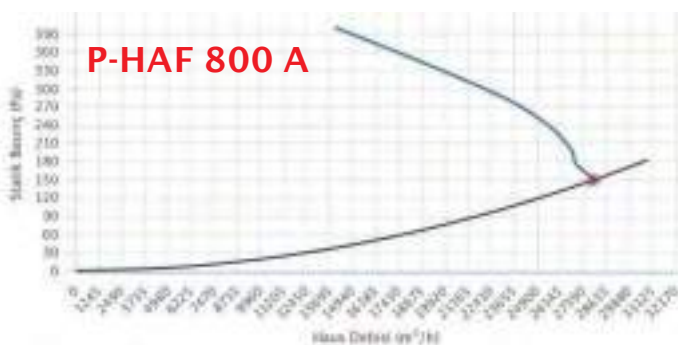
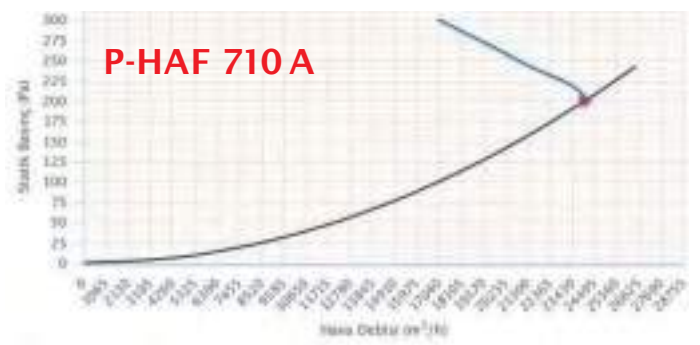
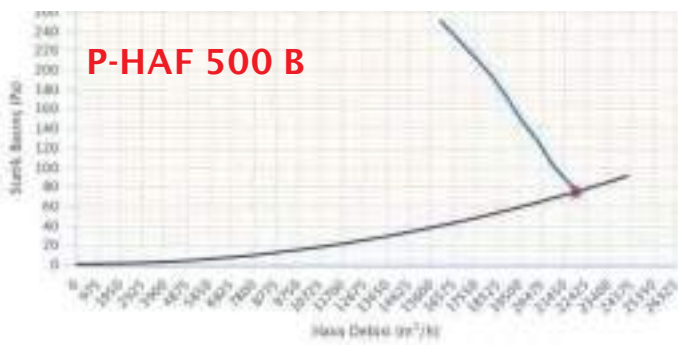
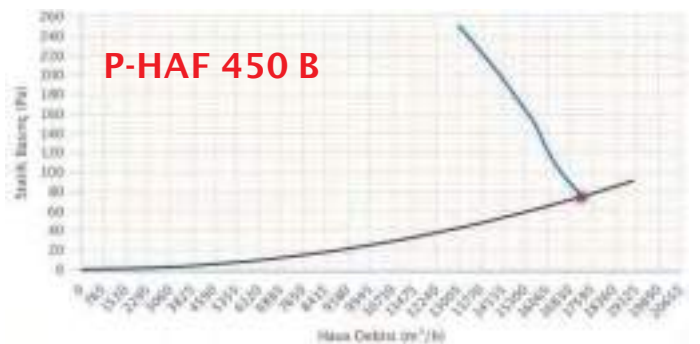
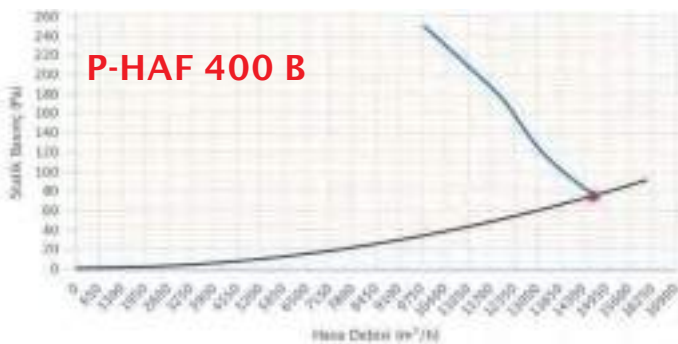
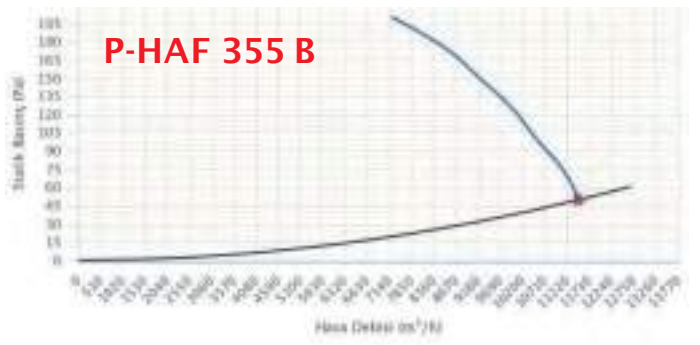
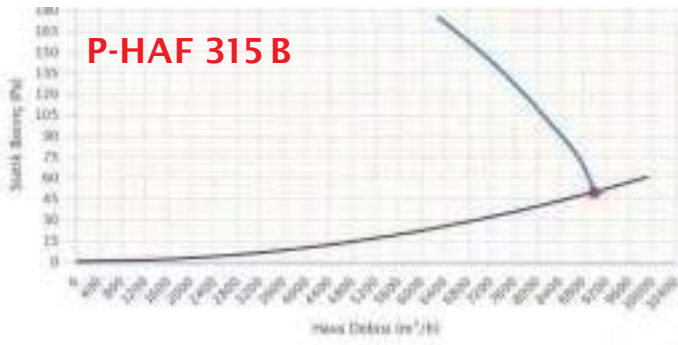
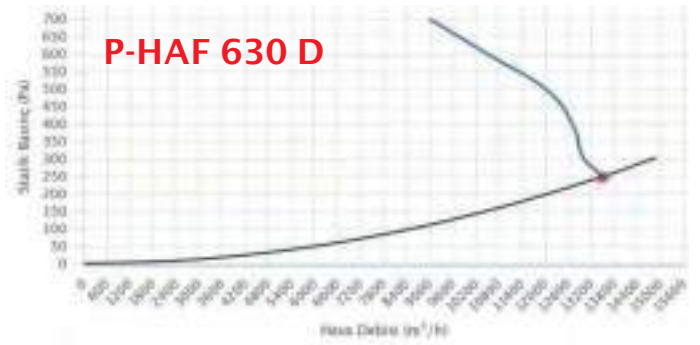
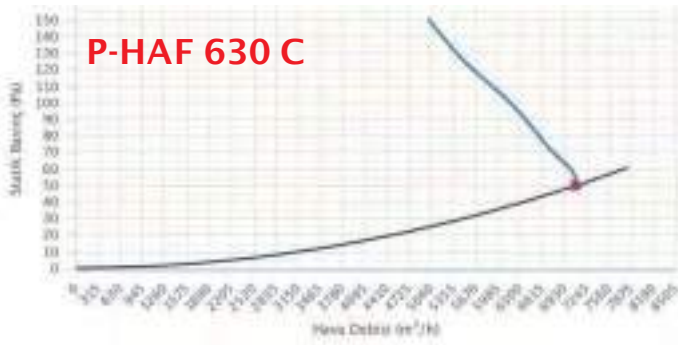

Performance Curves

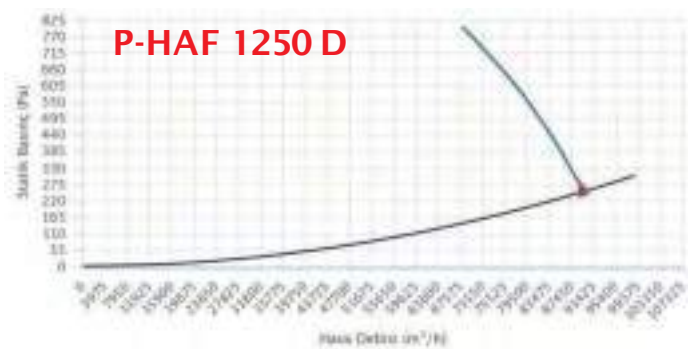
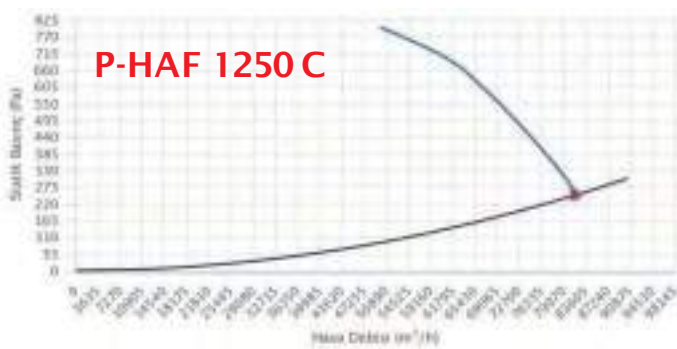
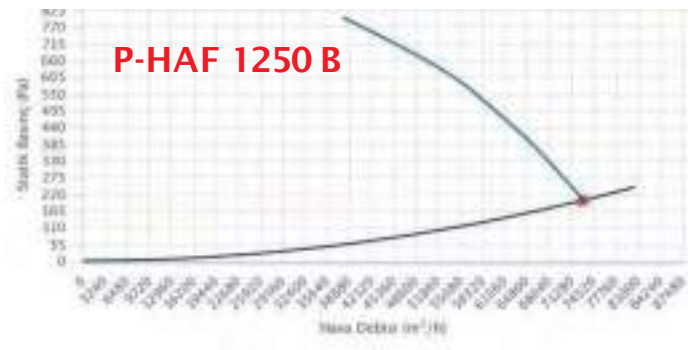
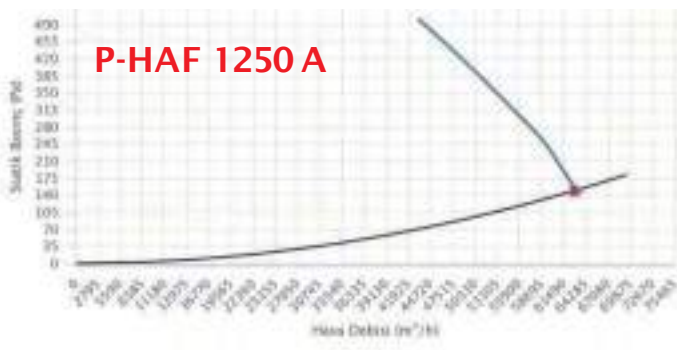
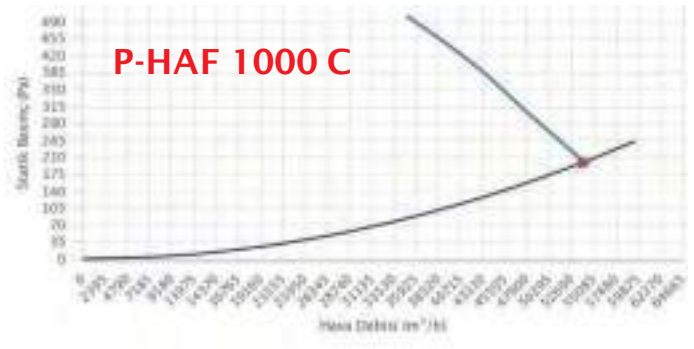
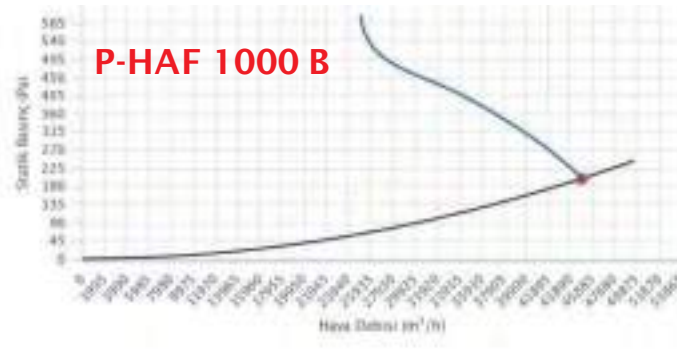
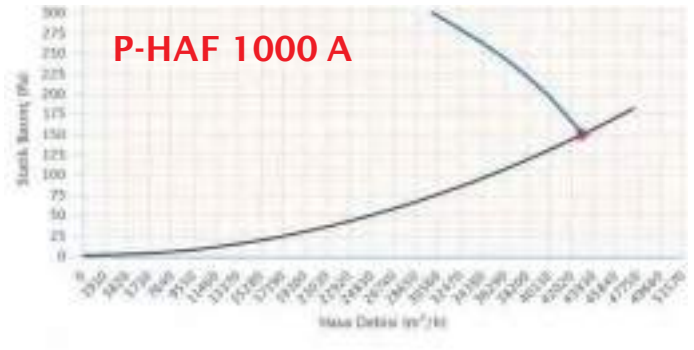
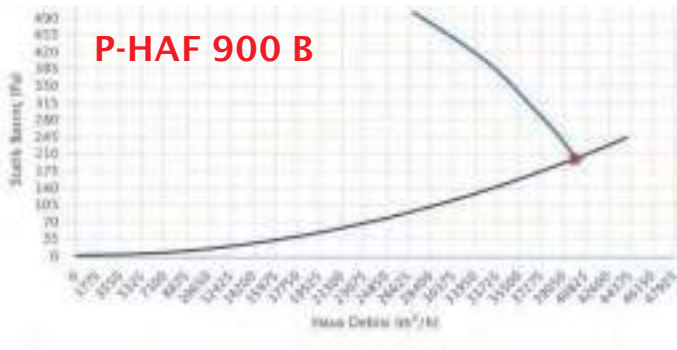
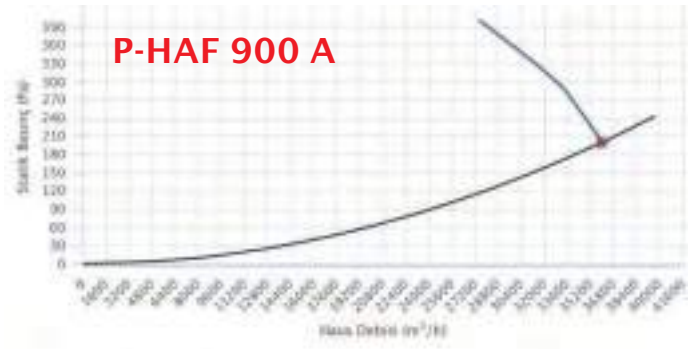
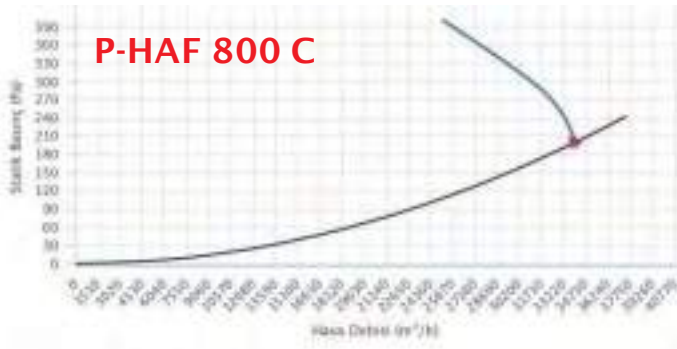

Duman Extraction Fan

DTF



point®



Utilization Areas



Description

- * Special propeller design
- * Protective wire mesh (Optional)
- * Galvanised Steel Sheet kasa
- * F300-F400 motor seçeneği
- * Electrostatic Powder Coating
- * Opposite flange(Optional)
- * Aluminum blades
- * Easy Installation

Technical Characteristics

MODELS	FLO W (m ³ /min)	PO WER (W)	VOLTA GE(V)	CUR RENT (A)	SP EED (RPM)	FREQ. (Hz)	NOI (dB(A))	D (mm)	DIMENSI ONS Hmax (mm)		Lmax (mm)	Dmax (mm)
P-DTF 355 A	5500	0.75	380	1.7	3000	50	90	355	455	300	415	
P-DTF 355 B	6100	1.1	380	2.3	3000	50	90	355	455	300	415	
P-DTF 400 A	10000	1.5	380	3.30	3000	50	90	400	500	400	460	
P-DTF 400 B	11000	2.2	380	4.50	3000	50	90	400	500	400	460	
P-DTF 450 A	13000	2.2	380	4.50	3000	50	90	450	550	400	510	
P-DTF 450 B	14100	3	380	5.90	3000	50	91	450	550	400	510	
P-DTF 500 A	17800	3.00	380	5.90	3000	50	91	500	600	400	560	
P-DTF 560 A	20000	3.00	380	5.90	3000	50	91	560	660	400	620	
P-DTF 630 A	22000	3.00	380	6.60	1500	50	92	630	730	500	690	
P-DTF 630 B	22500	4.00	380	8.40	1500	50	91	630	730	500	690	
P-DTF 710 A	26000	3	380	6.6	1500	50	93	710	810	500	770	
P-DTF 710 B	27000	4	380	8.4	1500	50	94	710	810	500	770	
P-DTF 710 C	31000	5.5	380	11.2	1500	50	95	710	810	500	770	
P-DTF 800 A	31800	3	380	6.6	1500	50	96	800	900	560	860	
P-DTF 800 B	35000	4	380	8.4	1500	50	97	800	900	560	860	
P-DTF 800 C	37000	5.5	380	11.2	1500	50	95	800	900	560	860	
P-DTF 900 A	40500	4	380	8.4	1500	50	95	900	1000	630	960	
P-DTF 900 B	44000	5.5	380	11.2	1500	50	95	900	1000	630	960	
P-DTF 900 C	47000	7.5	380	15.4	1500	50	96	900	1000	630	960	
P-DTF 1000 A	52000	5.5	380	11.2	1500	50	94	1000	1100	630	1060	
P-DTF 1000 B	58000	7.5	380	15.4	1500	50	97	1000	1100	630	1060	
P-DTF 1000 C	65000	11	380	21.3	1500	50	98	1000	1100	630	1060	
P-DTF 1000 D	72000	15	380	29.8	1500	50	99	1000	1100	630	1060	
P-DTF 1250 A	80000	15	380	29.8	1500	50	100	1250	1350	900	1310	
P-DTF 1250 B	88000	18.5	380	34.5	1500	50	102	1250	1350	900	1310	
P-DTF 1250 C	105000	22	380	42.5	1500	50	104	1250	1350	900	1310	
P-DTF 1250 D	120000	30	380	55	1500	50	105	1250	1350	900	1310	

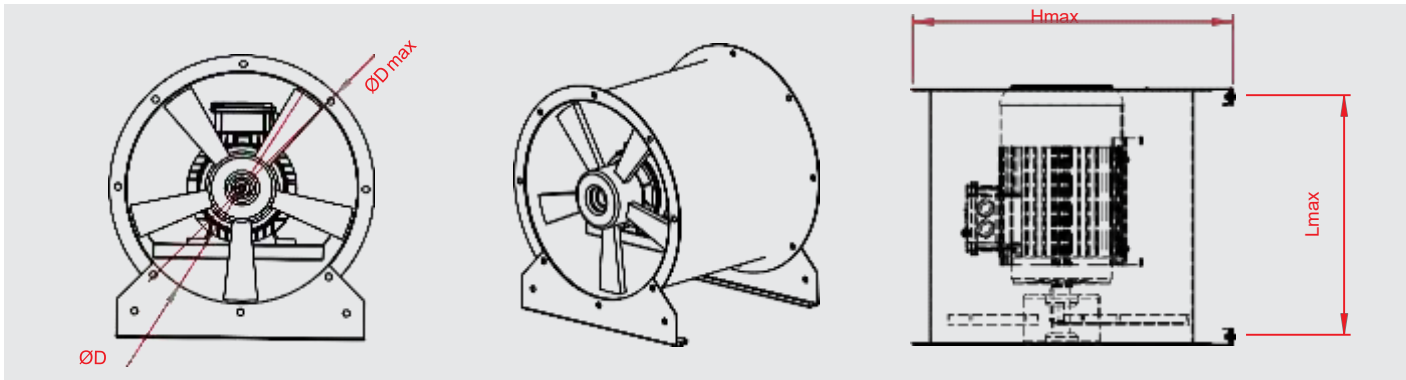

Performance Curves

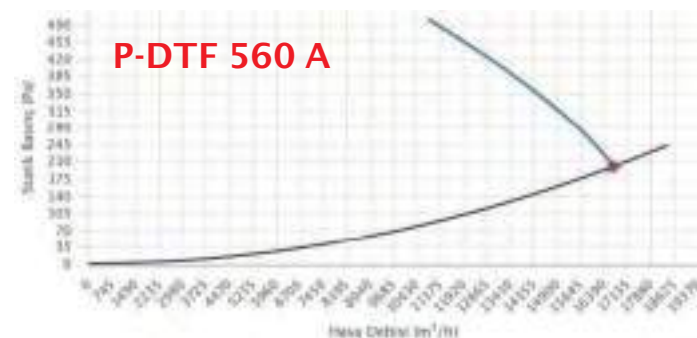
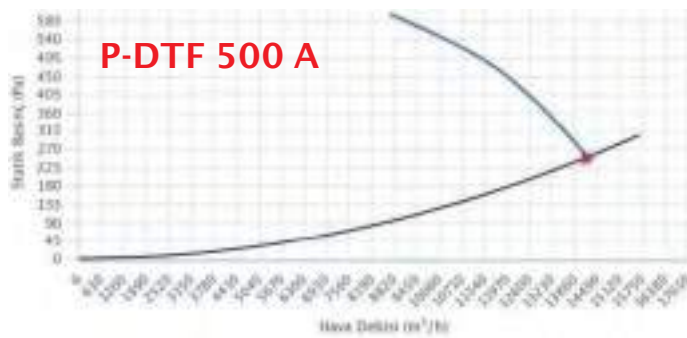
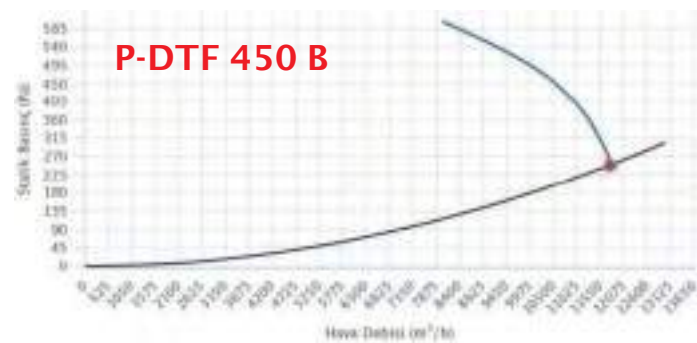
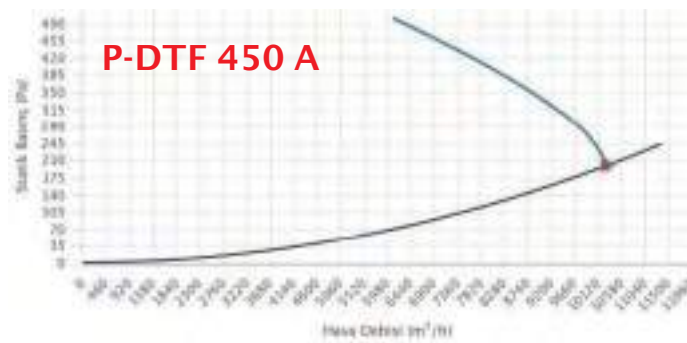
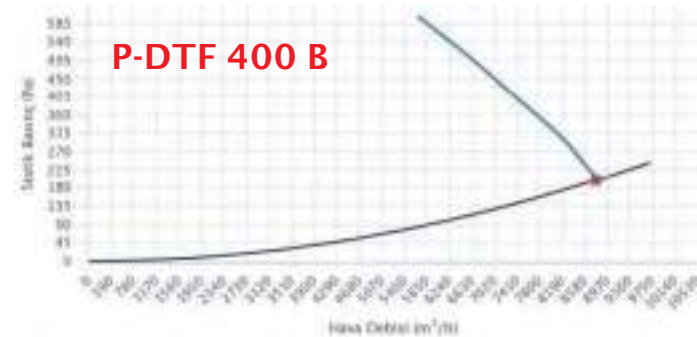
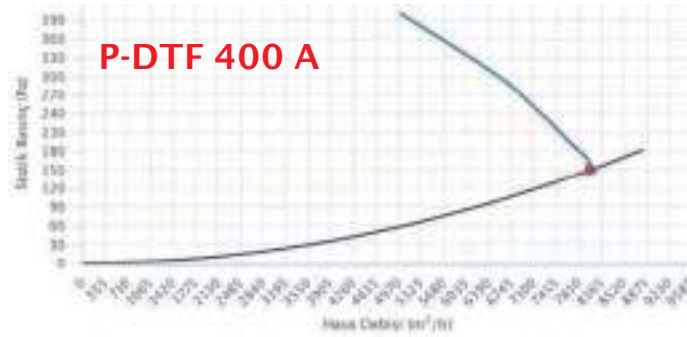
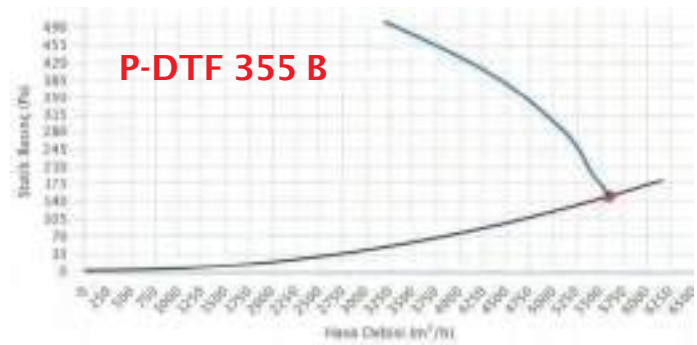
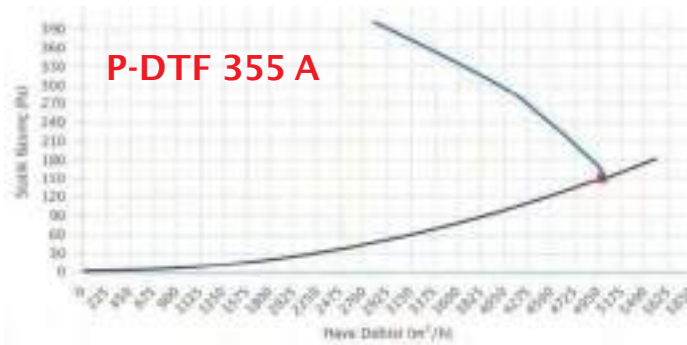

Performance Curves

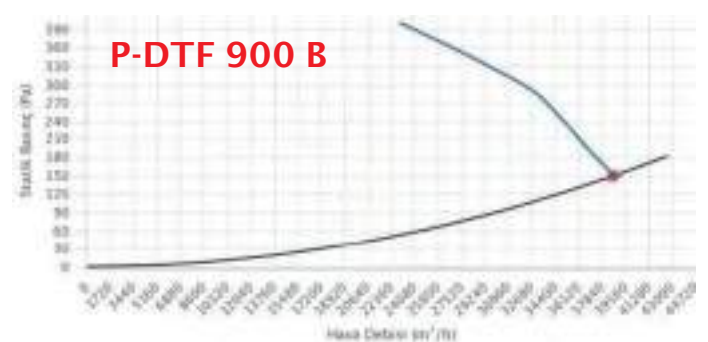
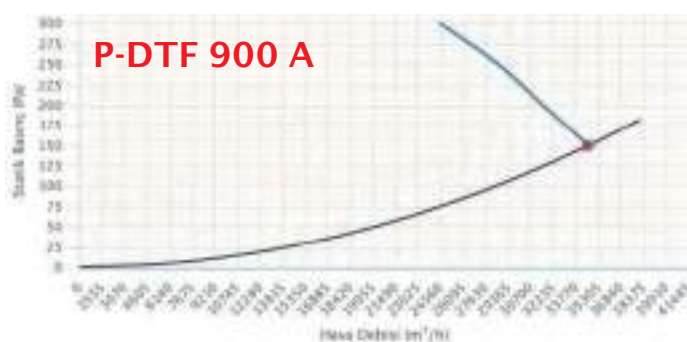
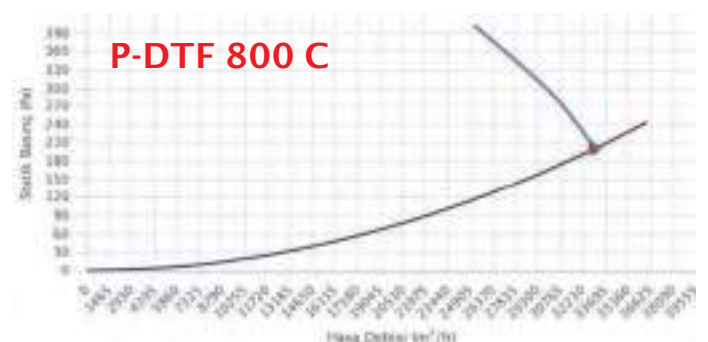
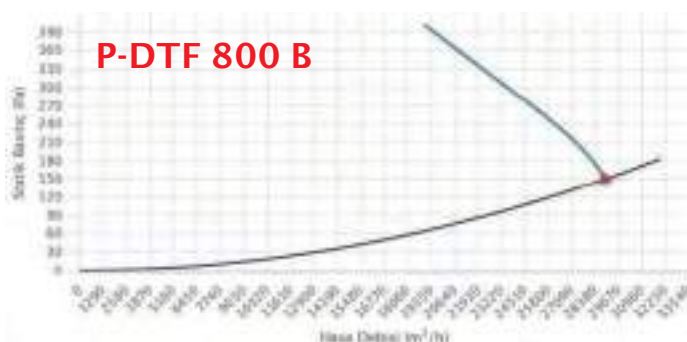
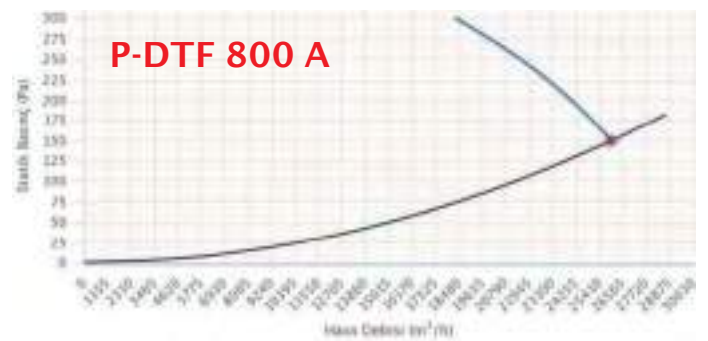
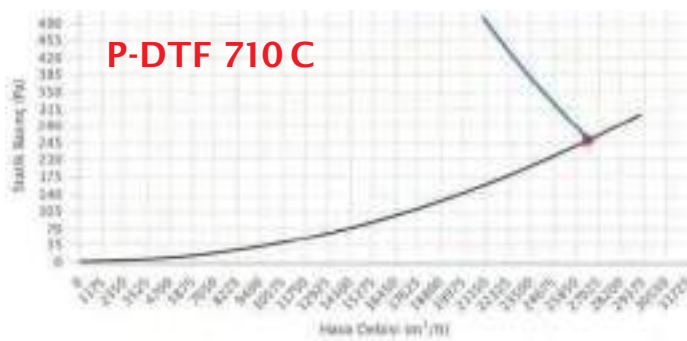
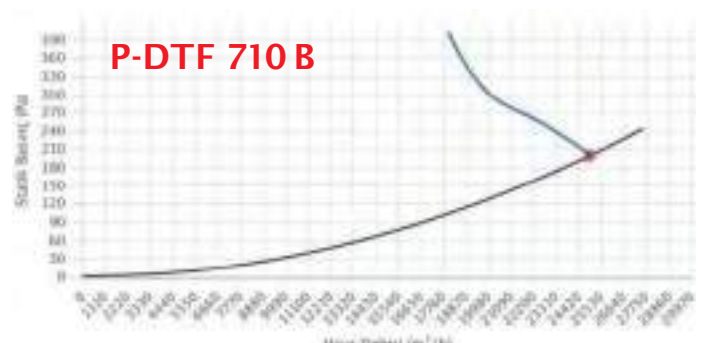
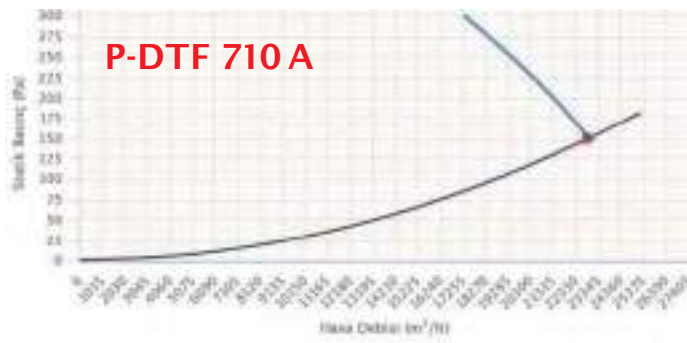
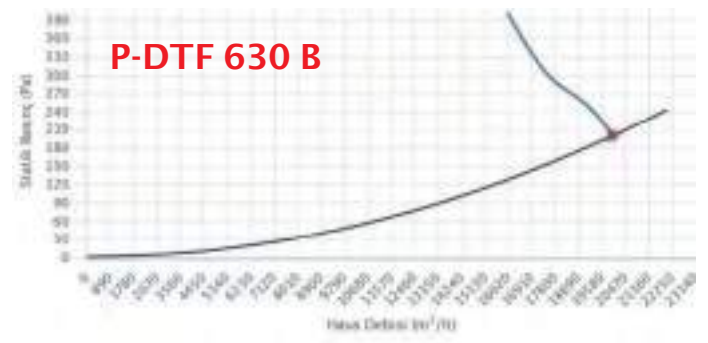
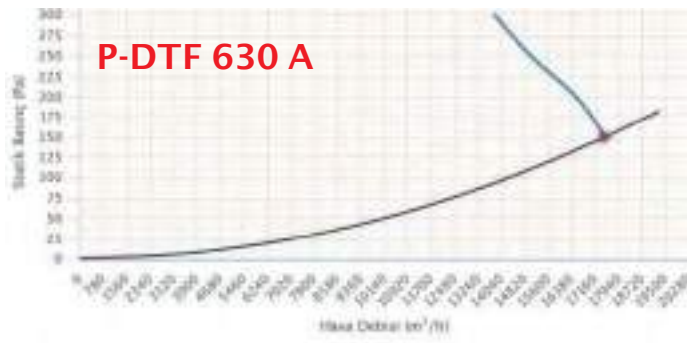

Performance Curves

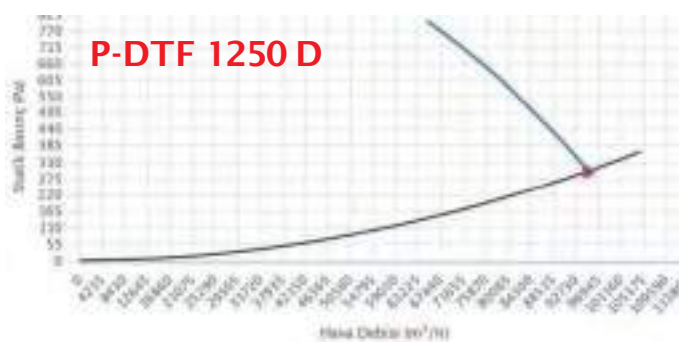
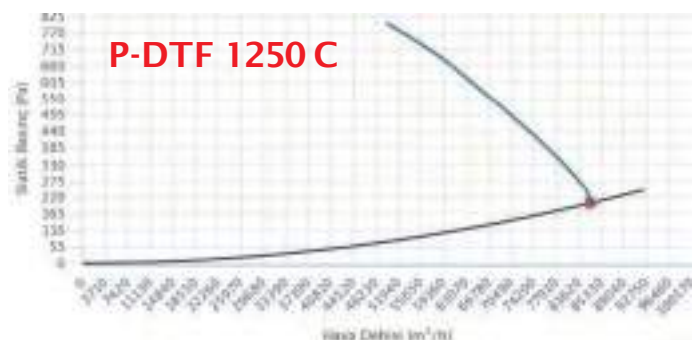
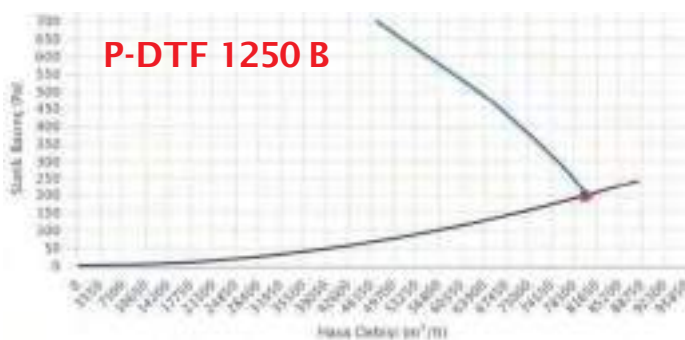
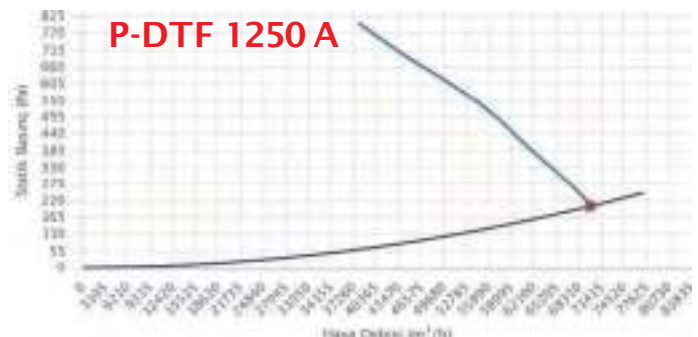
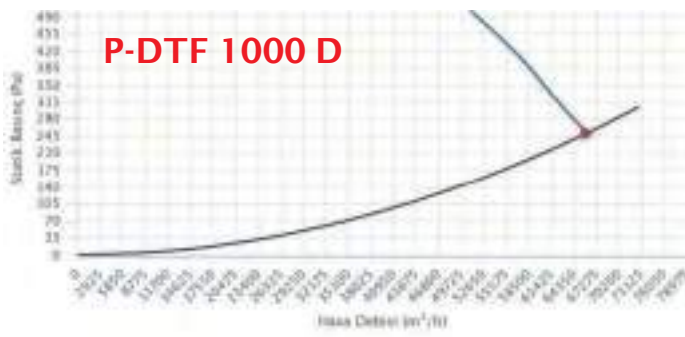
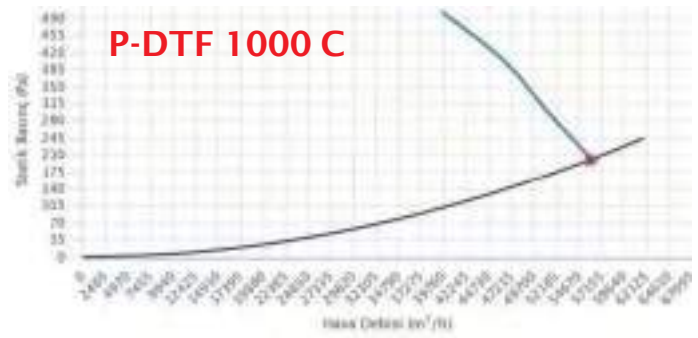
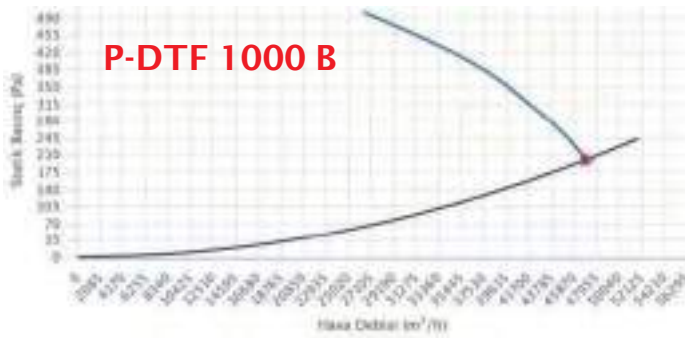
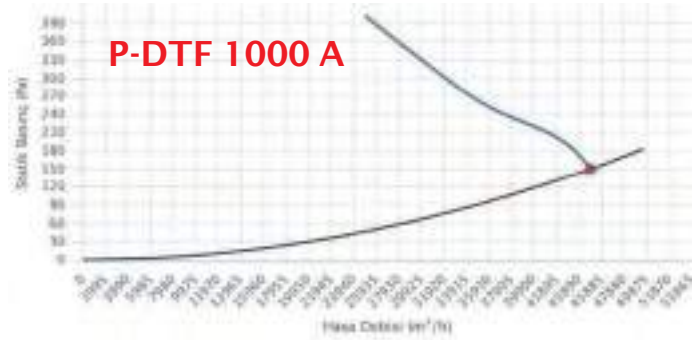
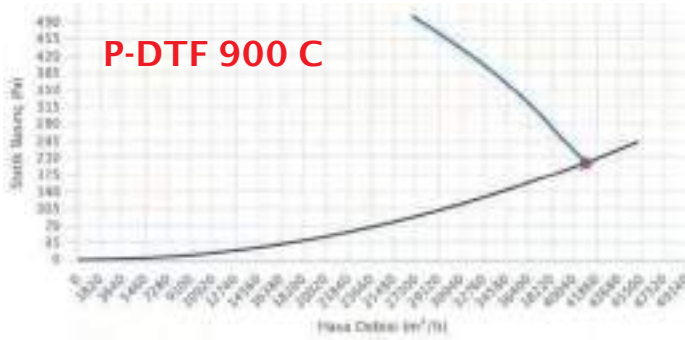

Roof Type Duman Extraction Fan

CDTF



Utilization Areas



Description

- * F300-F400 Motor Options
- * Special Blade Design
- * Aluminun Propeller
- * Easy Installation
- * Water-proof Characteristics
- * Electrostatic Powder Coating

Technical Characteristics

MODELS	FLOW (m³/h)	POWER (kW)	VOLTAGE (V)	CURRENT (A)	SPEED (rpm)	FREQ. (Hz)	NOISE (dbA)	B (mm)	DIMENSIONS Hmax (mm)	W (mm)
P-CDTF 355 A	5500	0,75	380	1,7	3000	50	90	455	640	555
P-CDTF 355 B	6100	1,1	380	2,3	3000	50	90	455	640	555
P-CDTF 400 A	10000	1,5	380	3,30	3000	50	90	500	640	600
P-CDTF 400 B	11000	2,2	380	4,50	3000	50	90	500	640	600
P-CDTF 450 A	13000	2,2	380	4,50	3000	50	90	550	690	650
P-CDTF 450 B	14100	3	380	5,90	3000	50	91	550	690	650
P-CDTF 500 A	17800	3,00	380	5,90	3000	50	91	600	690	700
P-CDTF 560 A	20000	3,00	380	5,90	3000	50	91	660	770	760
P-CDTF 630 A	22000	3,00	380	6,60	1500	50	92	730	770	830
P-CDTF 630 B	22500	4,00	380	8,40	1500	50	91	730	770	830
P-CDTF 710 A	26000	3	380	6,6	1500	50	93	810	890	910
P-CDTF 710 B	27000	4	380	8,4	1500	50	94	810	890	910
P-CDTF 710 C	31000	5,5	380	11,2	1500	50	95	810	890	910
P-CDTF 800 A	31800	3	380	6,6	1500	50	96	900	970	1000
P-CDTF 800 B	35000	4	380	8,4	1500	50	97	900	970	1000
P-CDTF 800 C	37000	5,5	380	11,2	1500	50	95	900	970	1000
P-CDTF 900 A	40500	4	380	8,4	1500	50	95	810	890	910
P-CDTF 900 B	44000	5,5	380	11,2	1500	50	95	810	890	910
P-CDTF 900 C	47000	7,5	380	15,4	1500	50	96	810	890	910
P-CDTF 1000 A	52000	5,5	380	11,2	1500	50	94	1100	1100	1200
P-CDTF 1000 B	58000	7,5	380	15,4	1500	50	97	1100	1100	1200
P-CDTF 1000 C	65000	11	380	21,3	1500	50	98	1100	1100	1200
P-CDTF 1000 D	72000	15	380	29,8	1500	50	99	1100	1100	1200
P-CDTF 1250 A	80000	15	380	29,8	1500	50	100	1350	1210	1450
P-CDTF 1250 B	88000	18,5	380	34,5	1500	50	102	1350	1210	1450
P-CDTF 1250 C	105000	22	380	42,5	1500	50	104	1350	1210	1450
P-CDTF 1250 D	120000	30	380	55	1500	50	105	1350	1210	1450

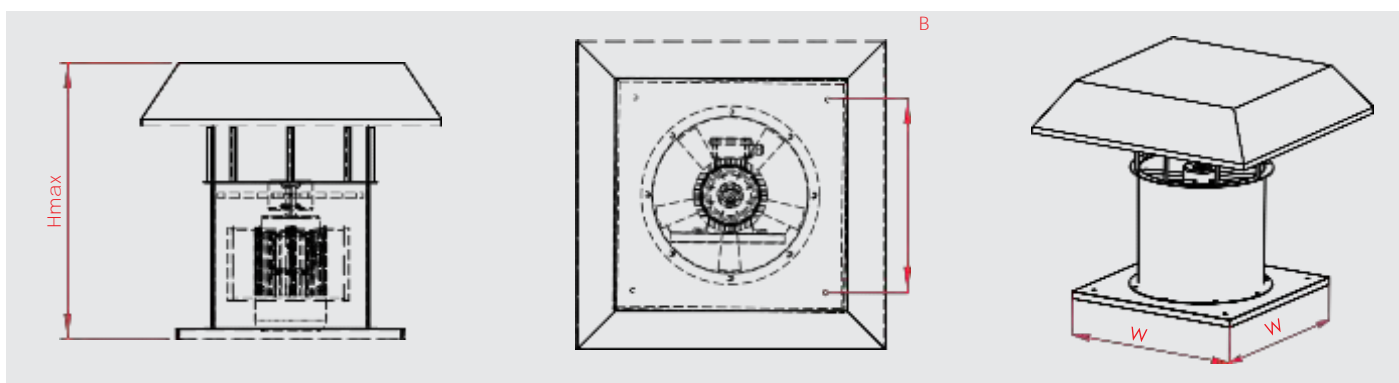

Performance Curves

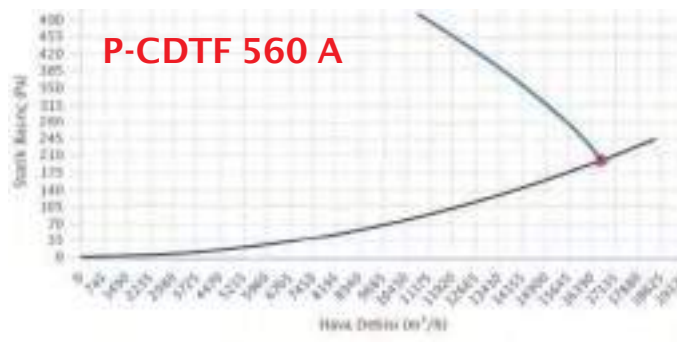
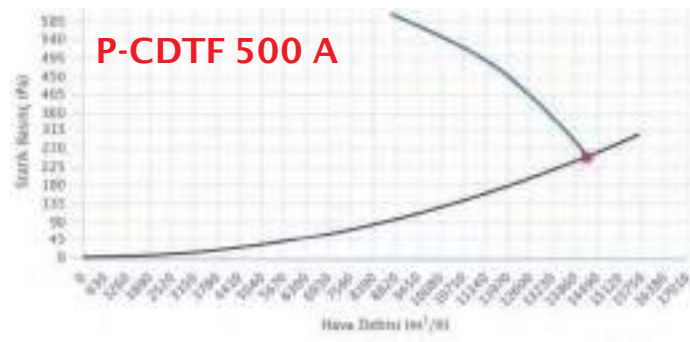
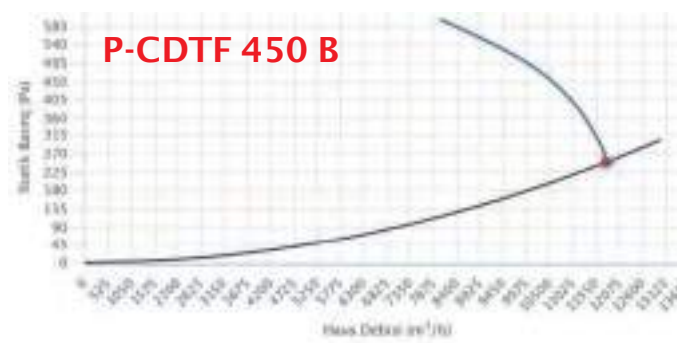
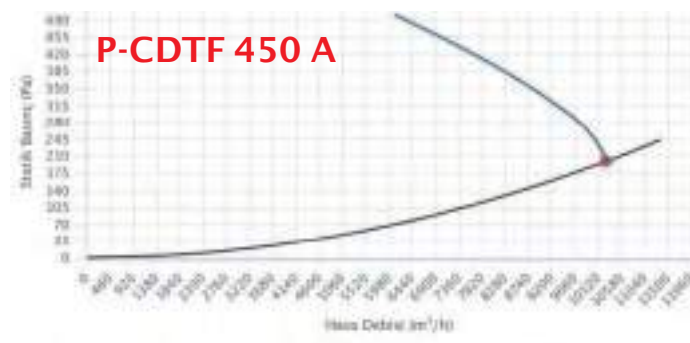
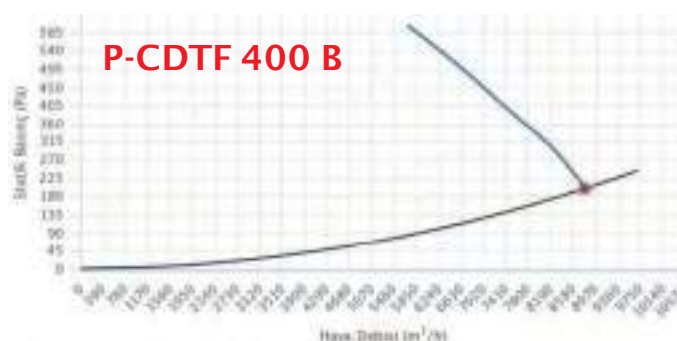
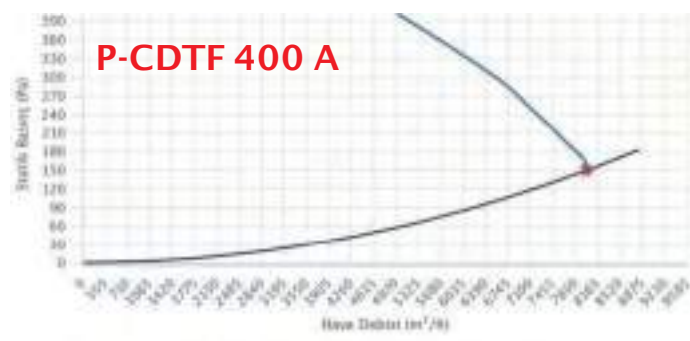
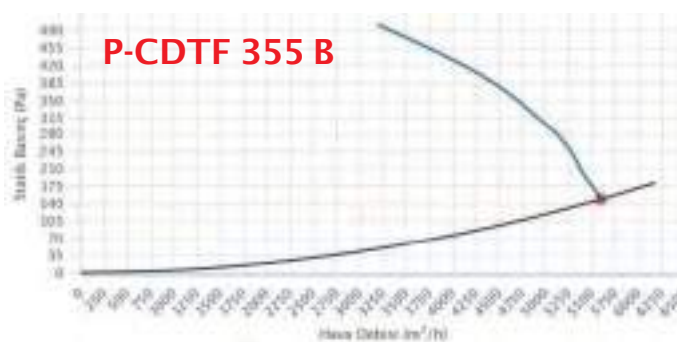
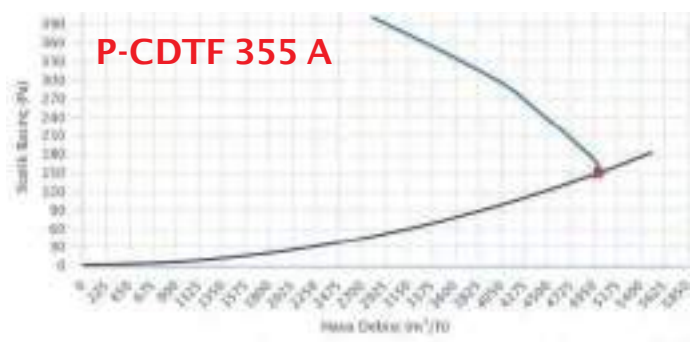

Performance Curves

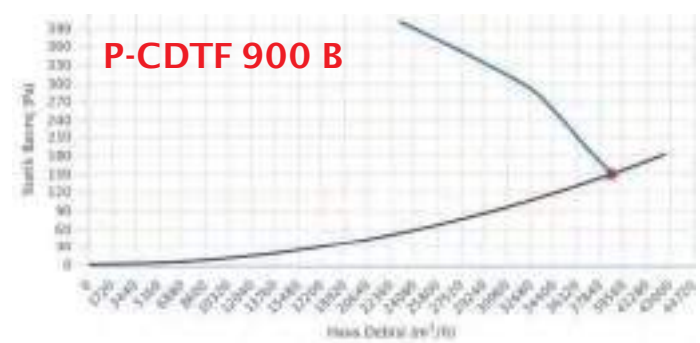
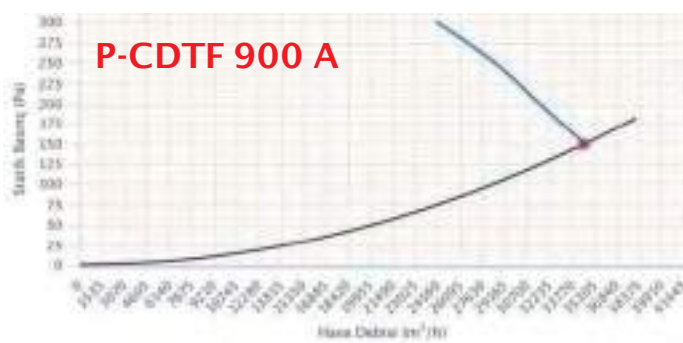
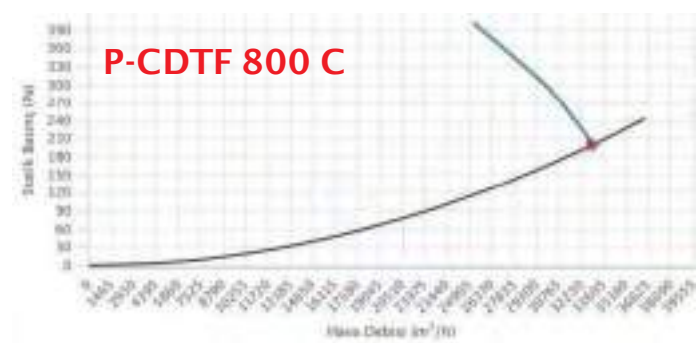
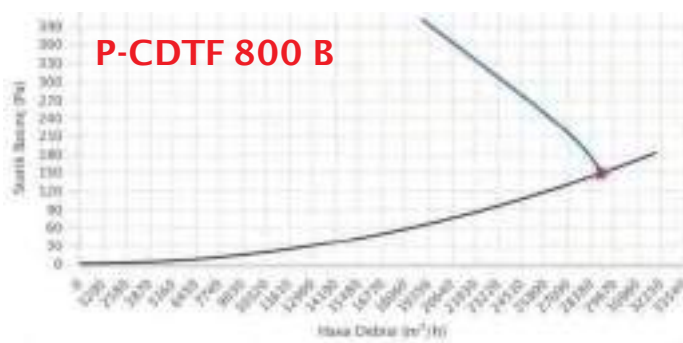
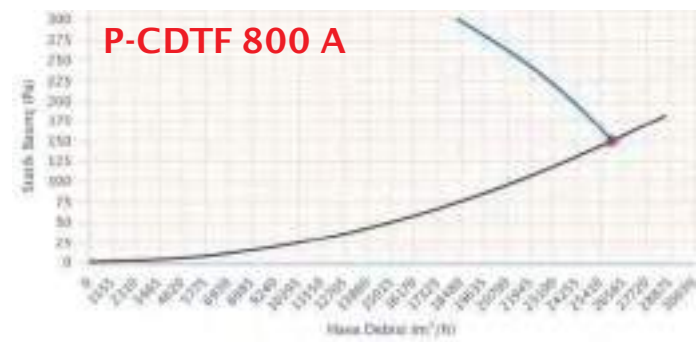
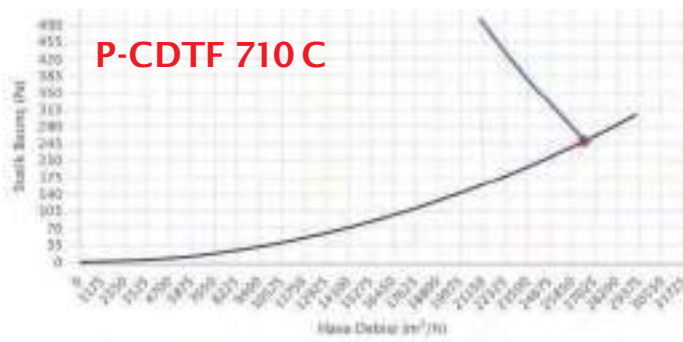
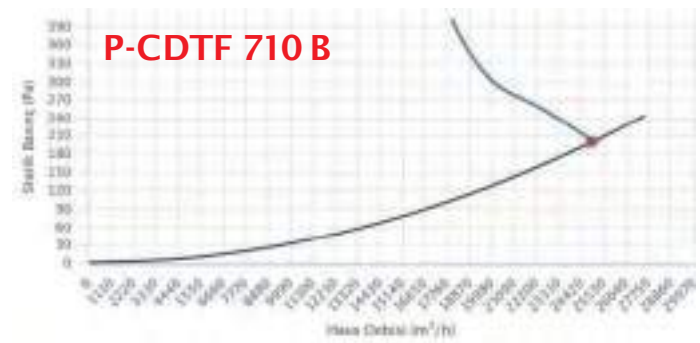
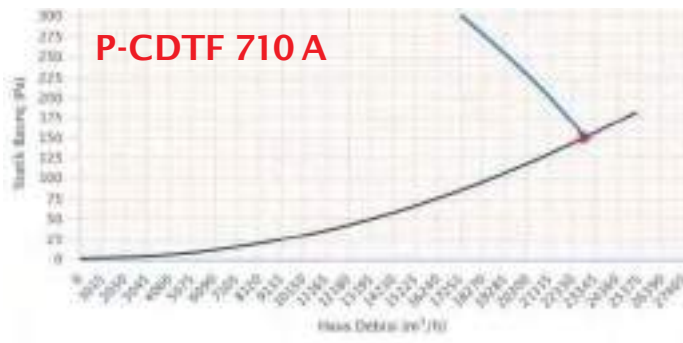
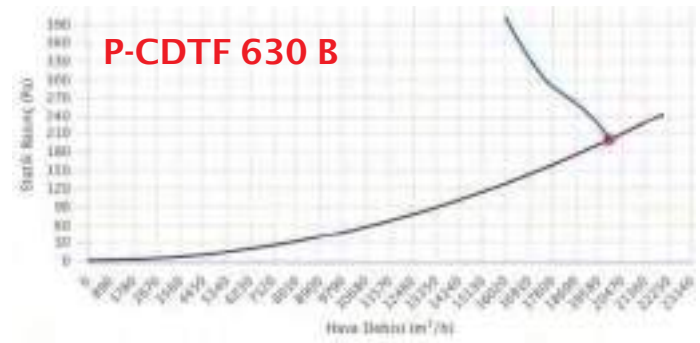
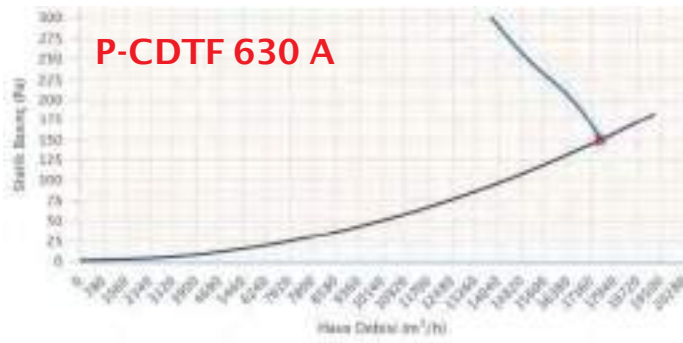

Performance Curves

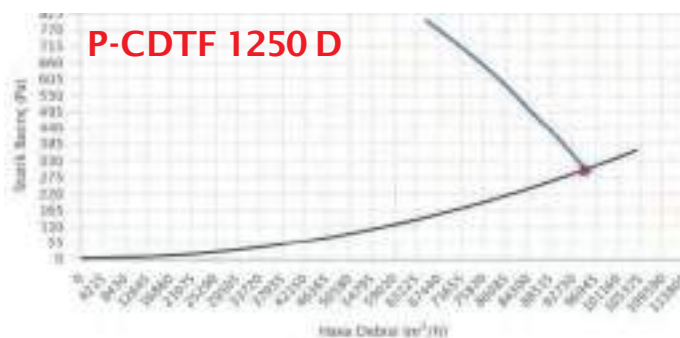
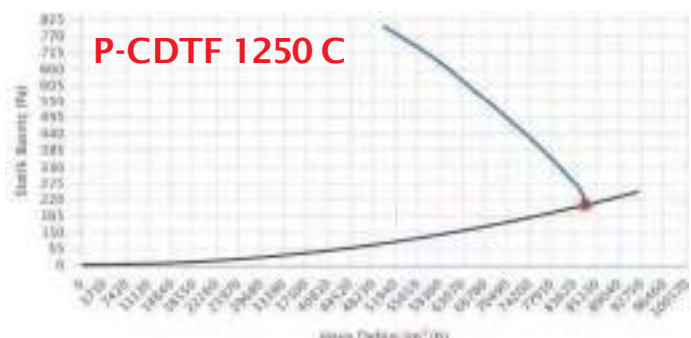
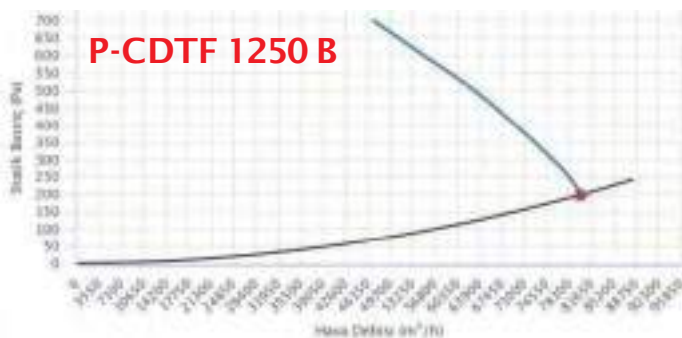
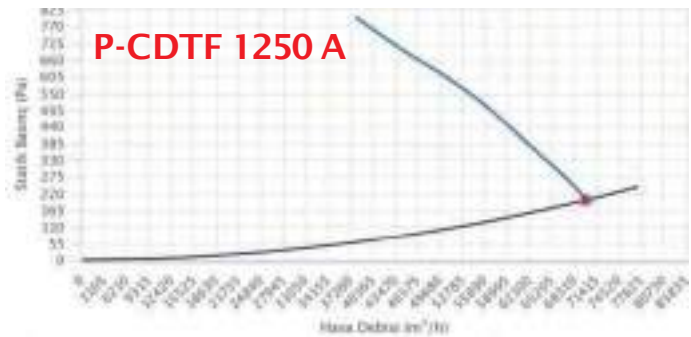
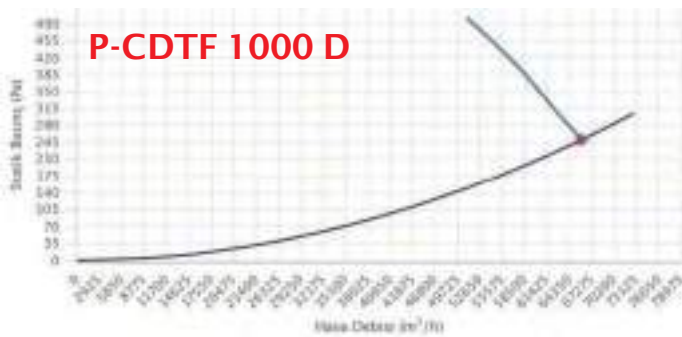
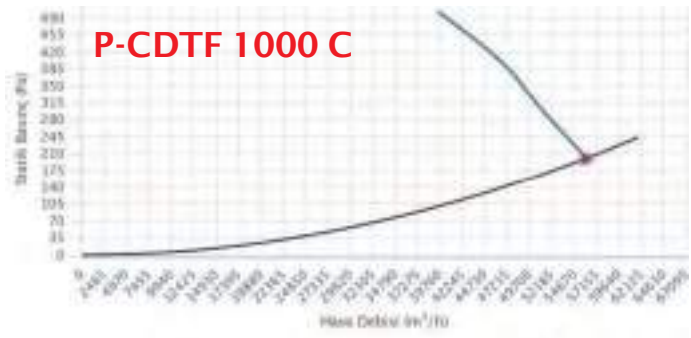
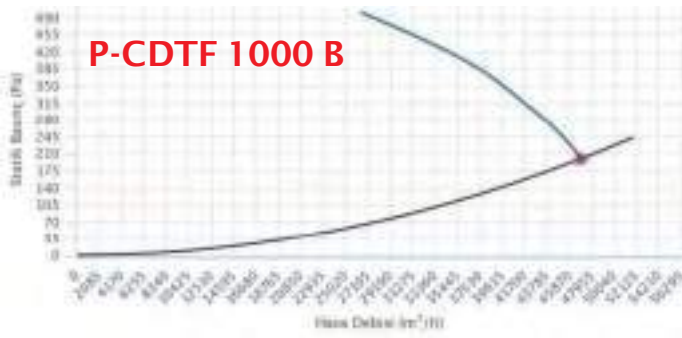
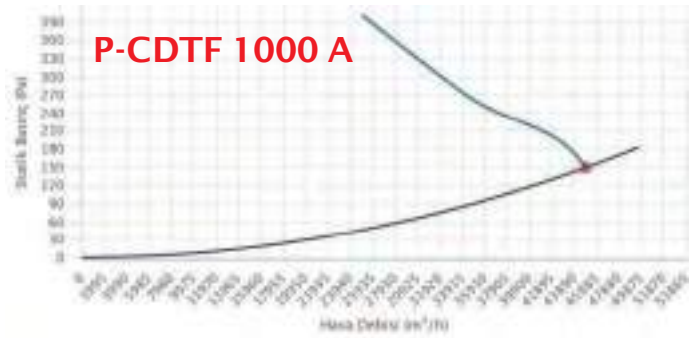
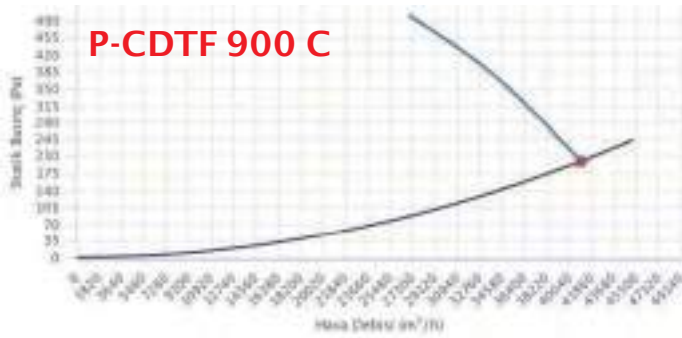

Cabinet/Cell Type Axial Duman Extraction Fan

HDTF



Utilization Areas



Description

- * Special propeller design
- * Aluminum blades
- * Internal silencer
- * Double wall panels
- * Aluminum profiles
- * IP55 protection
- * 300°-2H heat resistance motor
- * Easy maintenance

Technical Characteristics

MODELS	FLOW (m³/h)	POWER (kW)	VOLTAGE (V)	CURRENT (A)	SPEED (rpm)	FREQ. (Hz)	NOISE (dbA)	H (mm)	DIMENSIONS		L (mm)
									W (mm)	Hmax (mm)	
P-HDTF 355 A	5500	0,75	380	1,7	3000	50	41	635	635	735	460
P-HDTF 355 B	6100	1,1	380	2,3	3000	50	43	635	635	735	460
P-HDTF 400 A	10000	1,5	380	3,30	3000	50	45	680	680	780	460
P-HDTF 400 B	11000	2,2	380	4,50	3000	50	47	680	680	780	460
P-HDTF 450 A	13000	2,2	380	4,50	3000	50	51	730	730	830	510
P-HDTF 450 B	14100	3	380	5,90	3000	50	53	730	730	830	510
P-HDTF 500 A	17800	3,00	380	5,90	3000	50	55	780	780	880	510
P-HDTF 560 A	20000	3,00	380	5,90	3000	50	57	840	840	940	590
P-HDTF 630 A	22000	3,00	380	5,90	1500	50	59	910	910	1010	590
P-HDTF 630 B	22500	4,00	380	8,40	1500	50	61	910	910	1010	590
P-HDTF 710 A	26000	3	380	6,6	1500	50	63	990	990	1090	610
P-HDTF 710 B	27000	4	380	8,4	1500	50	65	990	990	1090	610
P-HDTF 710 C	31000	5,5	380	11,2	1500	50	67	990	990	1090	610
P-HDTF 800 A	31800	3	380	6,6	1500	50	69	1080	1080	1180	710
P-HDTF 800 B	35000	4	380	8,4	1500	50	71	1080	1080	1180	710
P-HDTF 800 C	37000	5,5	380	11,2	1500	50	73	1080	1080	1180	710
P-HDTF 900 A	40500	4	380	8,4	1500	50	75	1180	1180	1280	710
P-HDTF 900 B	44000	5,5	380	11,2	1500	50	77	1180	1180	1280	710
P-HDTF 900 C	47000	7,5	380	15,4	1500	50	79	1180	1180	1280	710
P-HDTF 1000 A	52000	5,5	380	11,2	1500	50	81	1280	1280	1380	825
P-HDTF 1000 B	58000	7,5	380	15,4	1500	50	83	1280	1280	1380	825
P-HDTF 1000 C	65000	11	380	21,3	1500	50	85	1280	1280	1380	825
P-HDTF 1000 D	72000	15	380	29,8	1500	50	87	1280	1280	1380	825
P-HDTF 1250 A	80000	15	380	29,8	1500	50	89	1530	1530	1630	930
P-HDTF 1250 B	88000	18,5	380	34,5	1500	50	91	1530	1530	1630	930
P-HDTF 1250 C	105000	22	380	42,5	1500	50	93	1530	1530	1630	930
P-HDTF 1250 D	120000	30	380	55	1500	50	95	1530	1530	1630	930

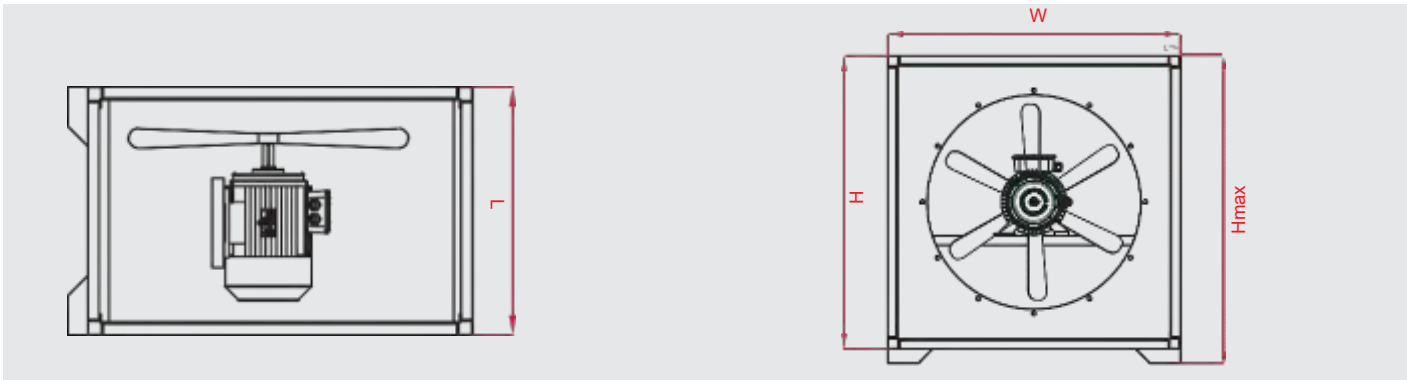

Performance Curves

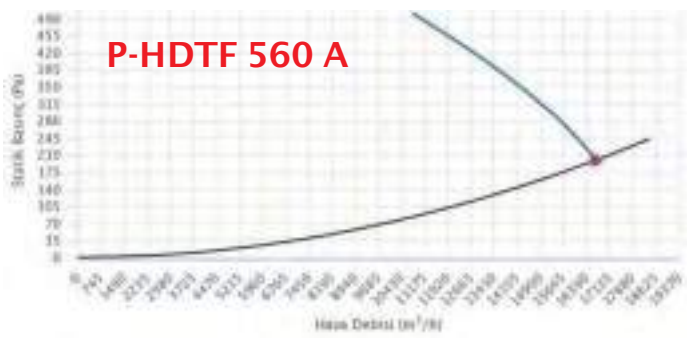
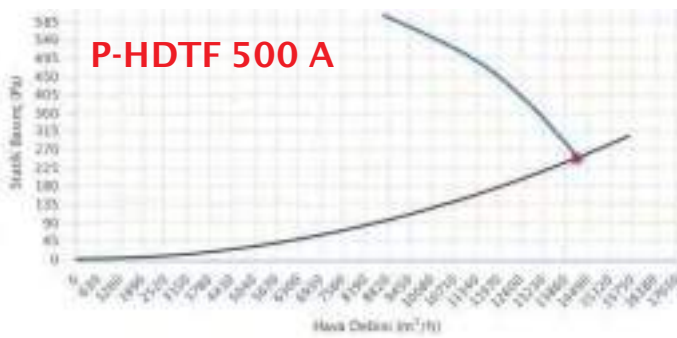
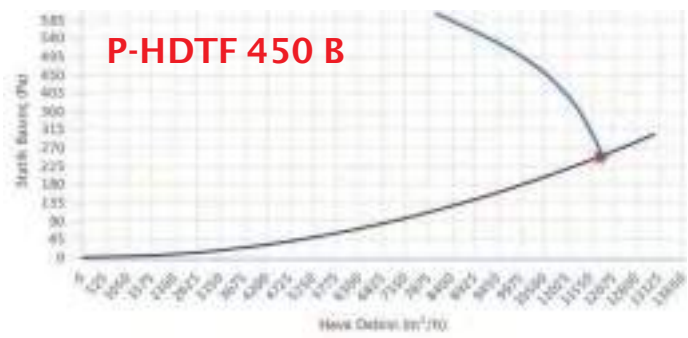
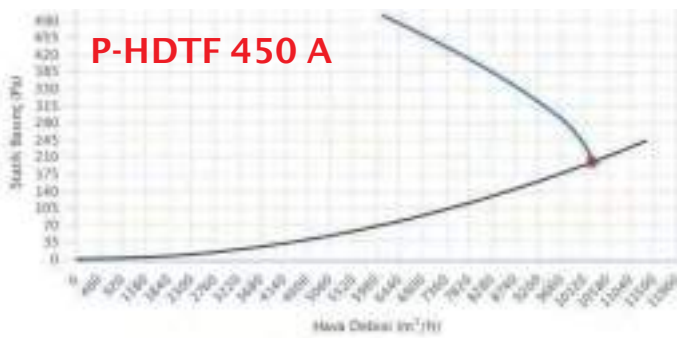
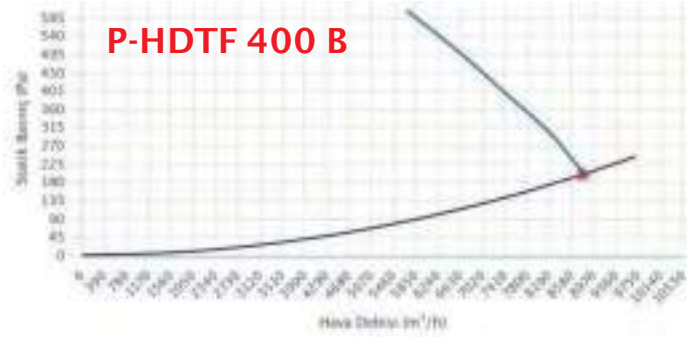
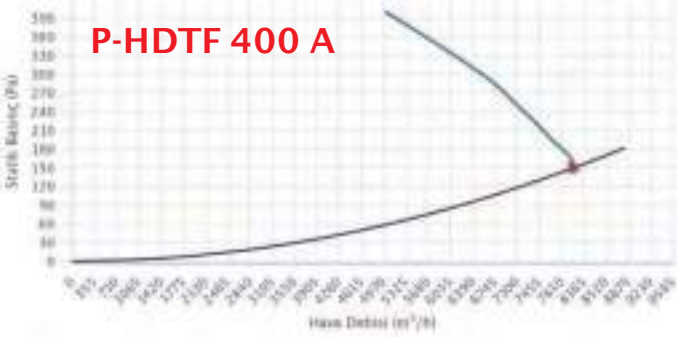
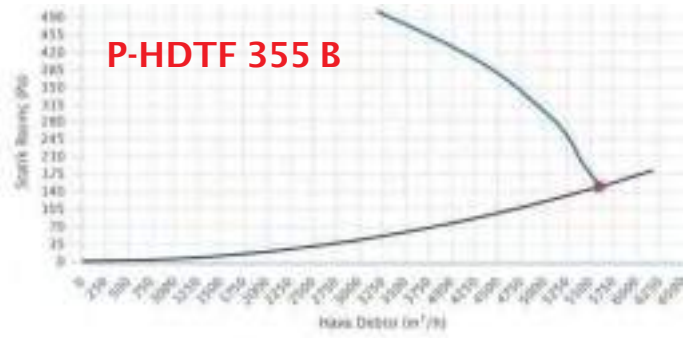
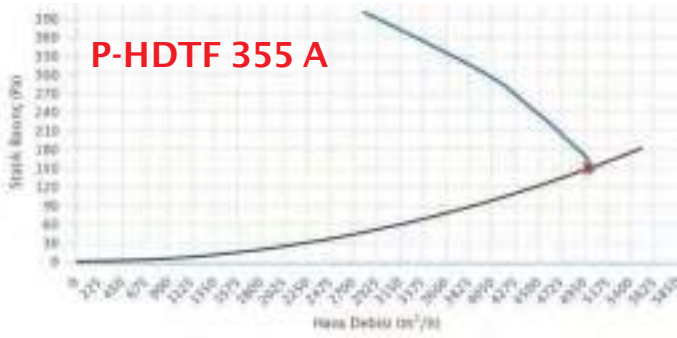

Performance Curves

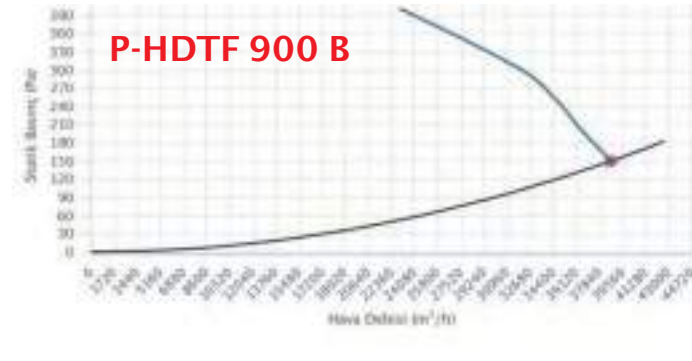
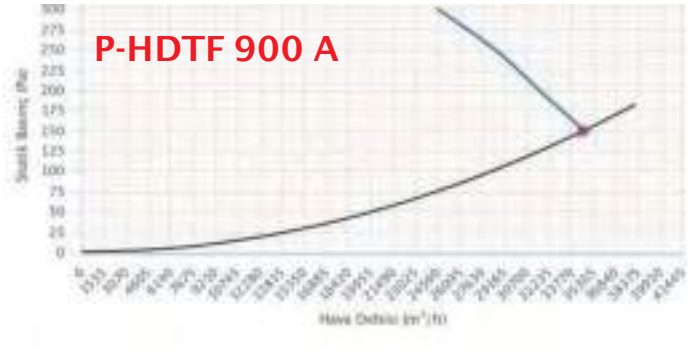
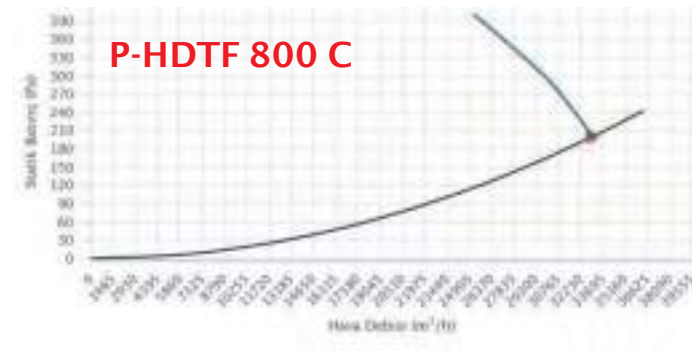
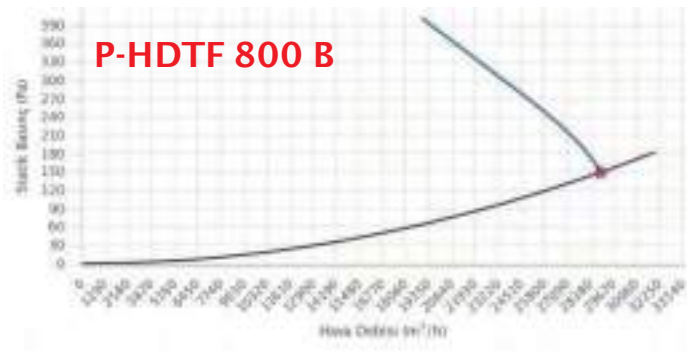
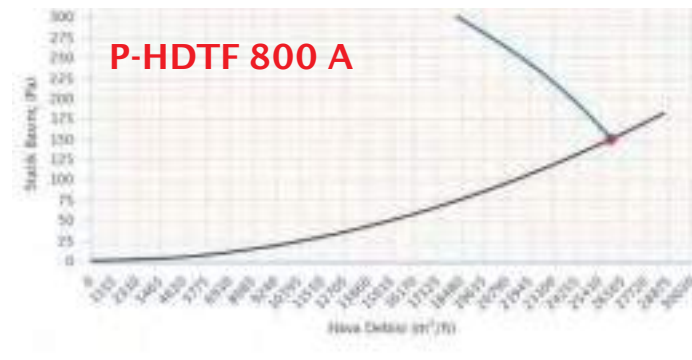
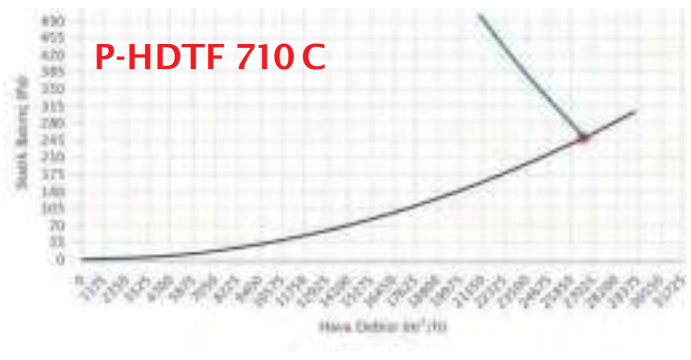
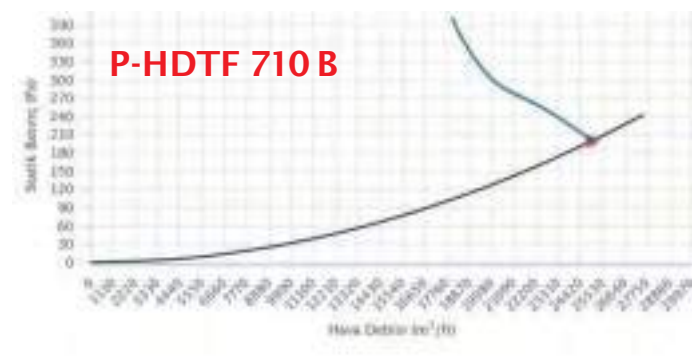
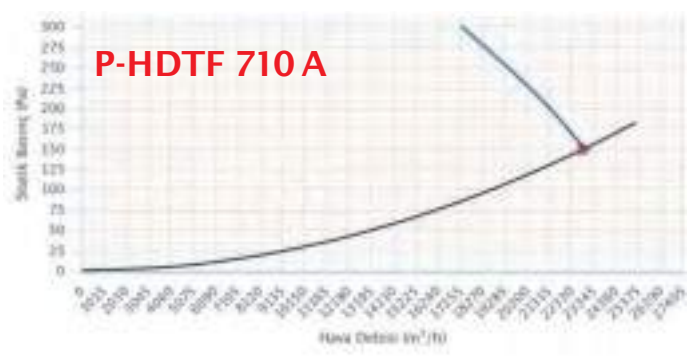
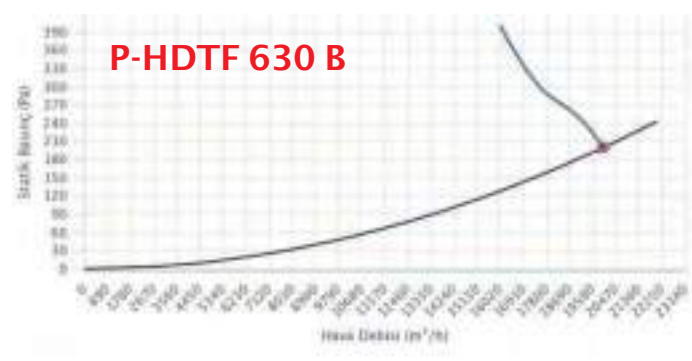
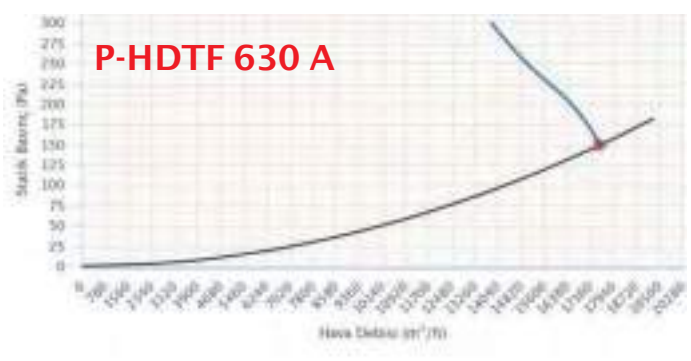

Performance Curves

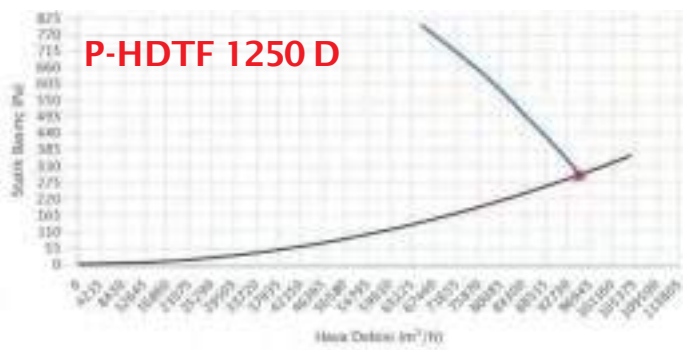
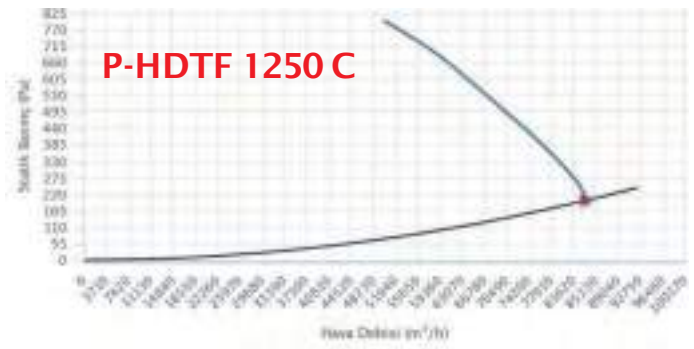
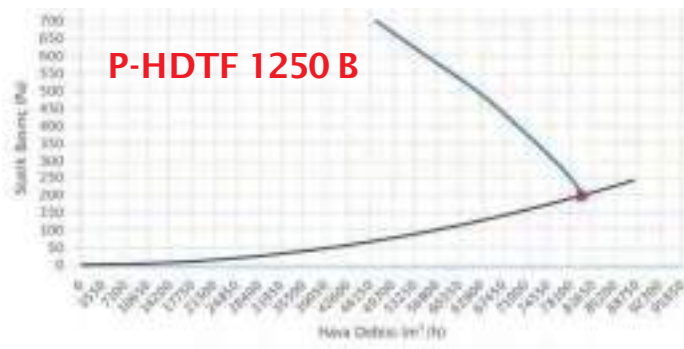
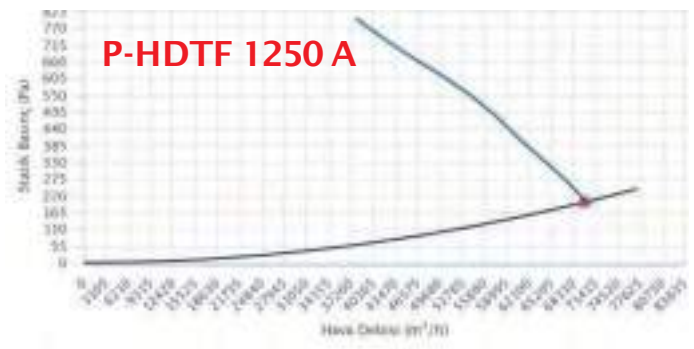
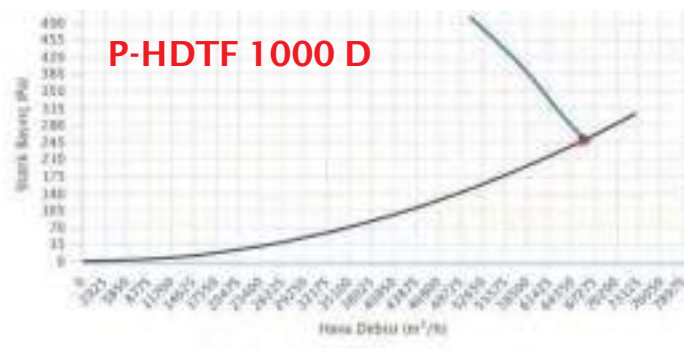
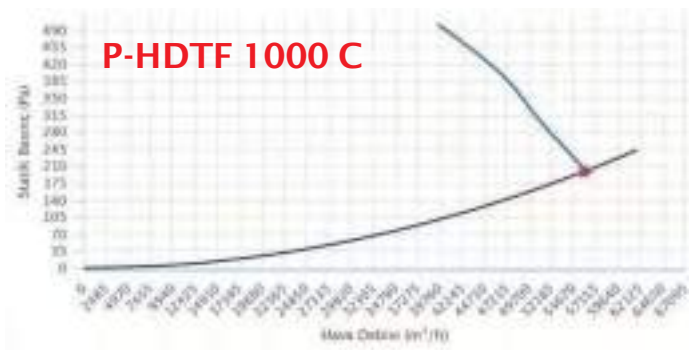
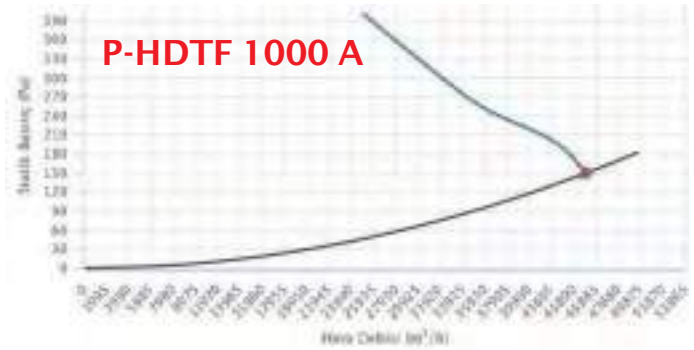
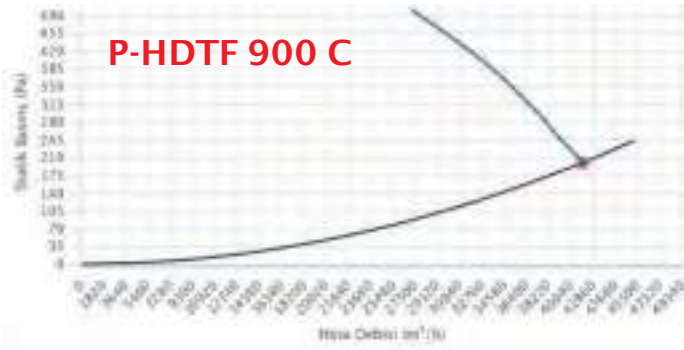

Axial Wall Type Fan

AF



Utilization Areas



Description

- * Low noise level
- * Special propeller design
- * Single or tri-phase motor
- * Protective wire mesh
- * Ease of application
- * Easy maintenance

Technical Drawing

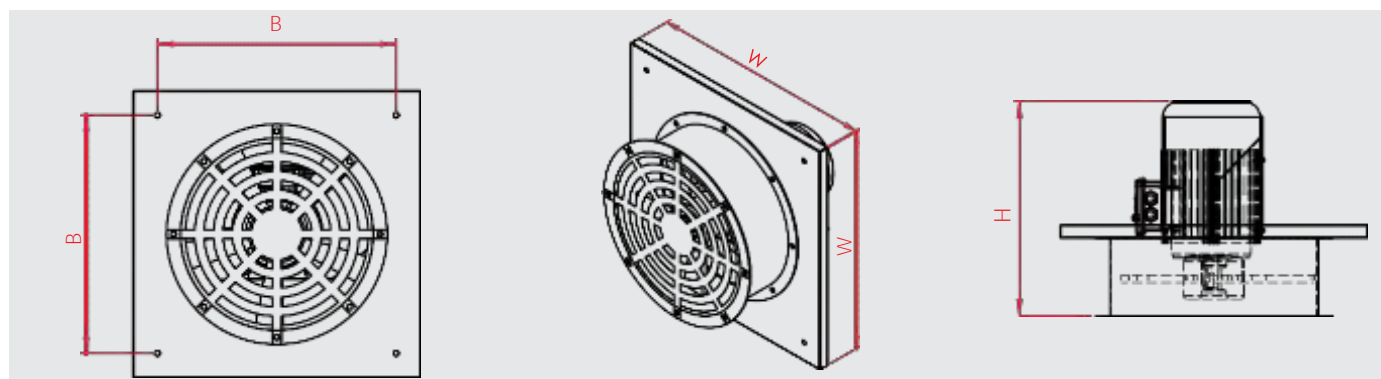

Technical Characteristics

MODELS	FLOW (m³/h)	POWER (kW)	VOLTAGE (V)	CURRENT (A)	SPEED (rpm)	FREQ. (Hz)	NOISE (dbA)	B (mm)	DIMENSIONS W (mm)	H (mm)
P-AF 400	5000	0,25	380	0.81	1450	50	64	500	600	180
P-AF 450	6000	0,37	380	1.15	1450	50	65	550	650	180
P-AF 500	7500	0,55	380	1.60	1450	50	68	600	700	180
P-AF 560	10000	0,55	380	1.60	1450	50	69	660	760	180
P-AF 630	12000	0,75	380	1.92	1450	50	70	730	830	180
P-AF 710 A	16000	1,5	380	3.50	1450	50	75	810	910	180
P-AF 710 B	18000	2,2	380	4.90	1450	50	76	810	910	180
P-AF 710 C	23000	3	380	6.70	1450	50	78	810	910	180

Performance Curves

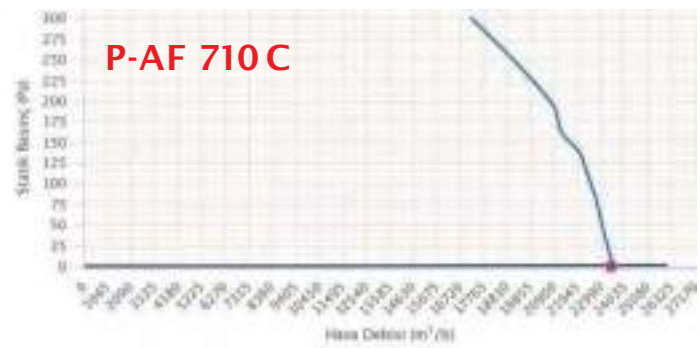
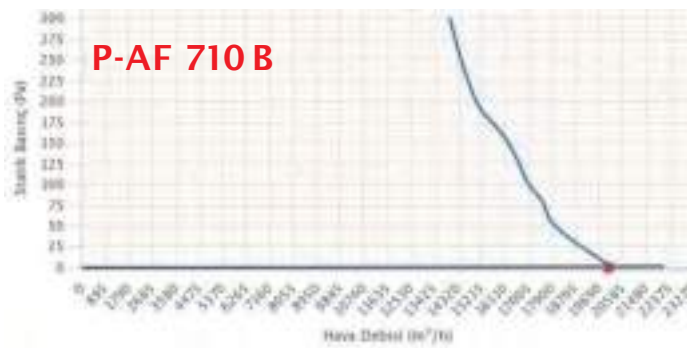
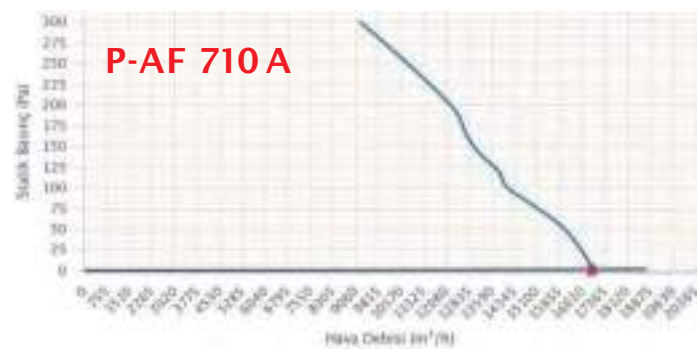
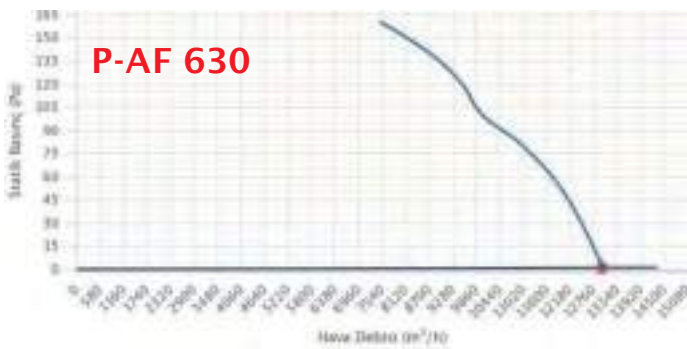
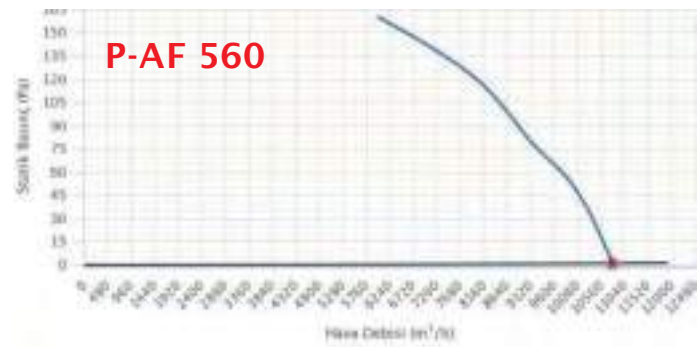
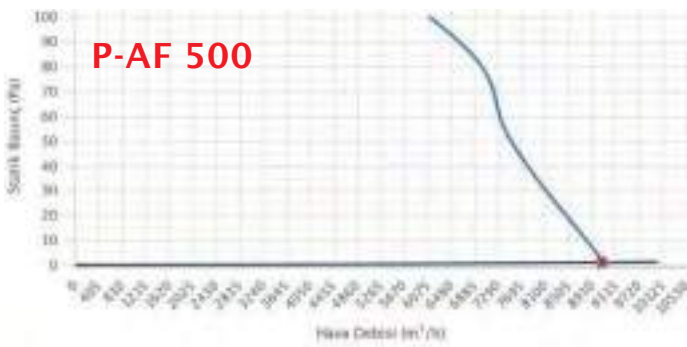
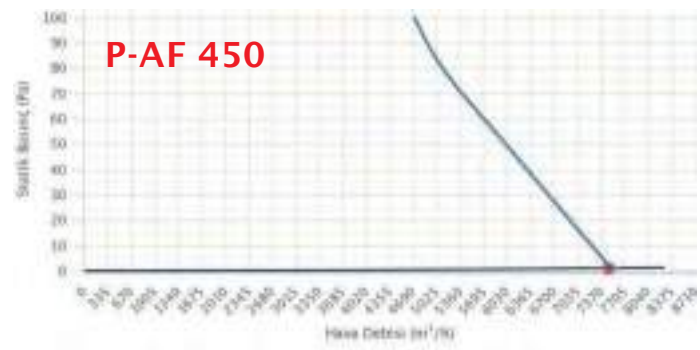
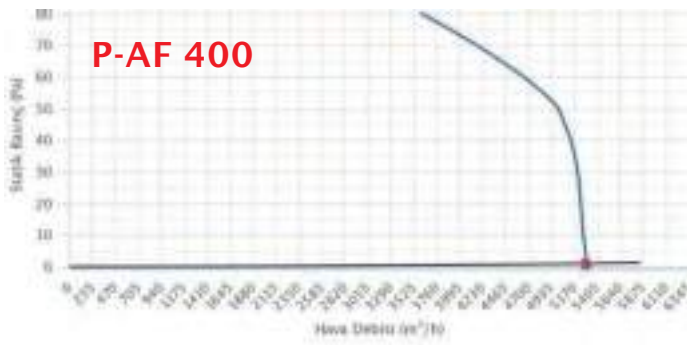

Axial (Ex-Proof) Wall Type Fan

AF-EX



Utilization Areas



Description

- * Ex-Proof Motor
- * Protective wire mesh
- * Low noise level
- * Special Blade Design
- * Easy installation maintenance
- * Electrostatic Powder Coating

Technical Drawing

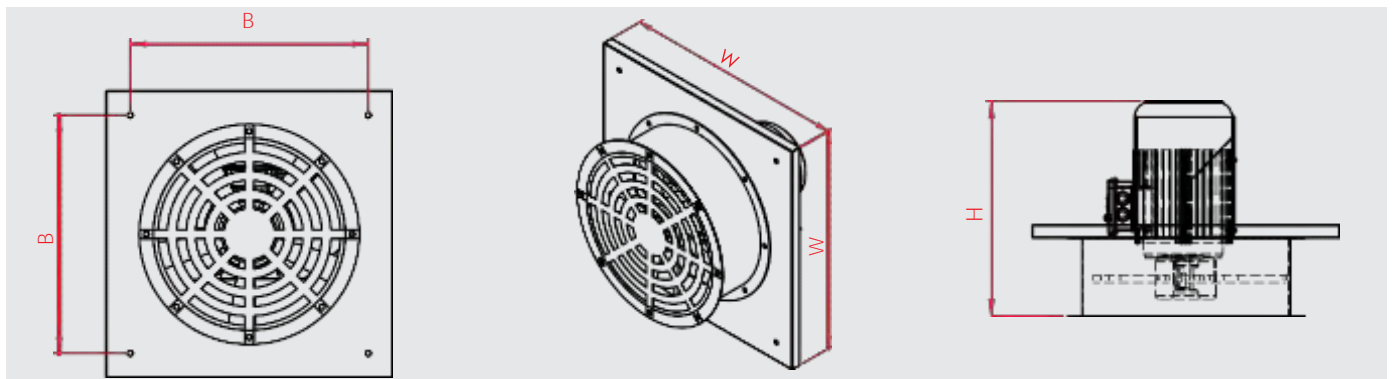

Technical Characteristics

MODELS	FLOW (m ³ /h)	POWER (kW)	VOLTAGE (V)	CURRENT (A)	SPEED (rpm)	FREQ. (Hz)	NOISE (dB(A))	B (mm)	DIMENSIONS W (mm)	H (mm)
P-AF EX 315	2600	0,25	380	0.81	1450	50	65	415	515	180
P-AF EX 355	3800	0,25	380	0.81	1450	50	66	455	555	180
P-AF EX 400	5300	0,25	380	0.81	1450	50	64	500	600	180
P-AF EX 450	7500	0,37	380	1.15	1450	50	65	550	650	180
P-AF EX 500	9100	0,55	380	1.60	1450	50	68	600	700	180
P-AF EX 560	10800	0,55	380	1.60	1450	50	69	660	760	180
P-AF EX 630	13000	0,75	380	1.92	1450	50	70	730	830	180
P-AF EX 710 A	17000	1,5	380	3.50	1450	50	75	810	910	180
P-AF EX 710 B	20100	2,2	380	4.90	1450	50	76	810	910	180
P-AF EX 710 C	23500	3	380	6.70	1450	50	78	810	910	180

Performance Curves

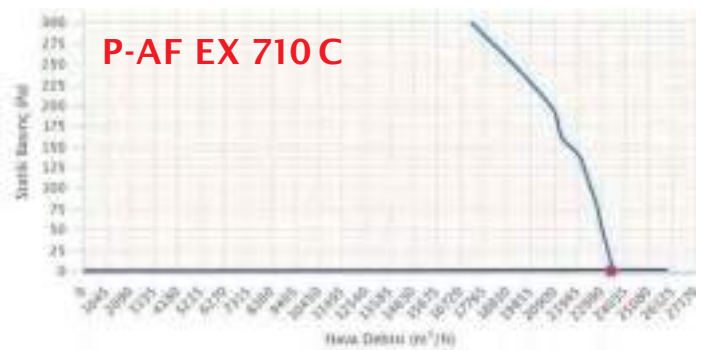
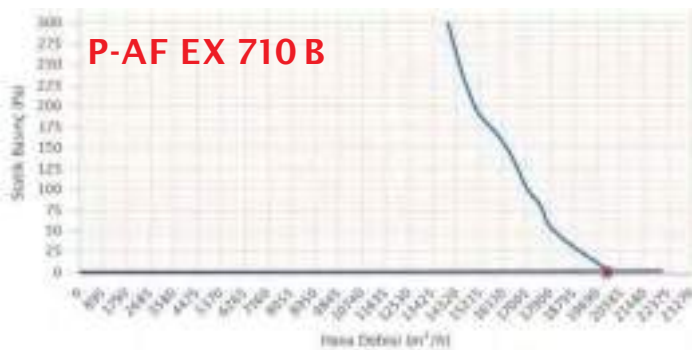
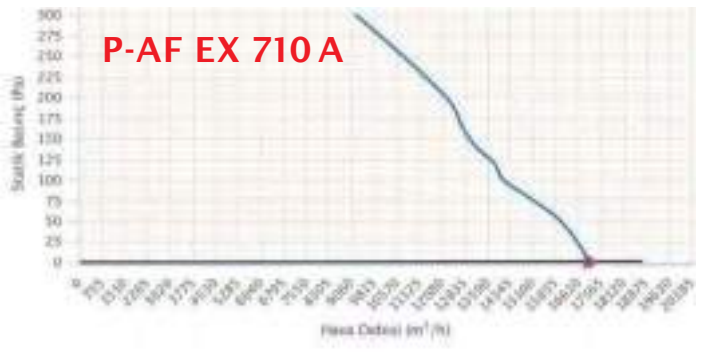
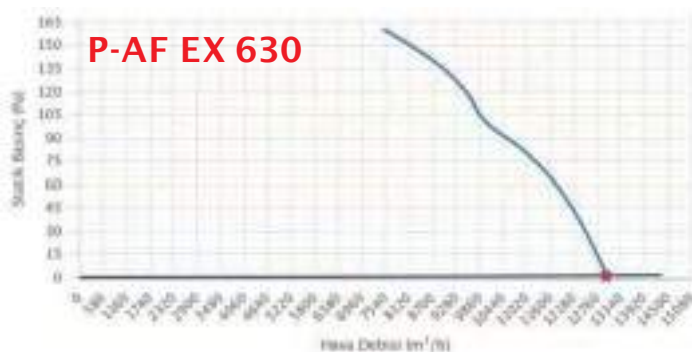
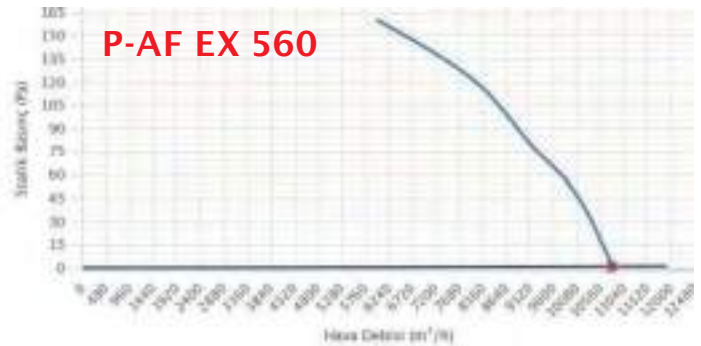
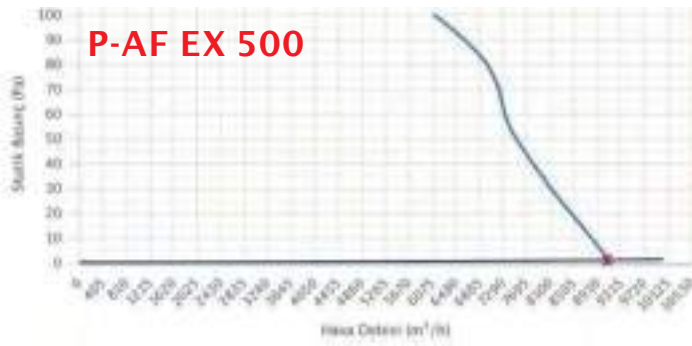
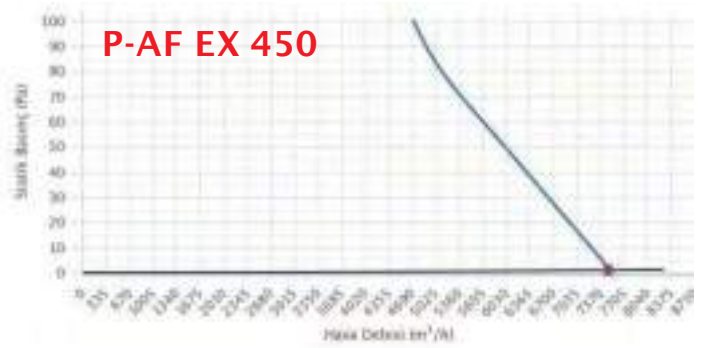
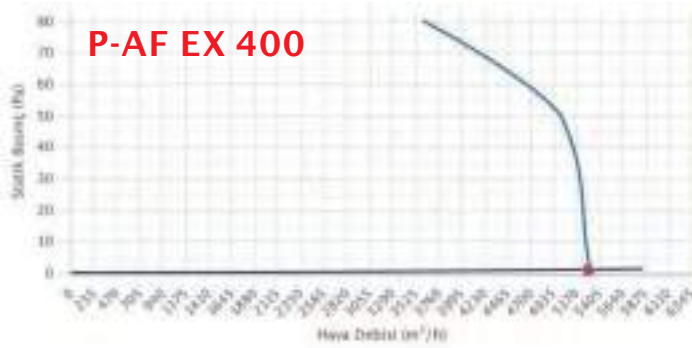
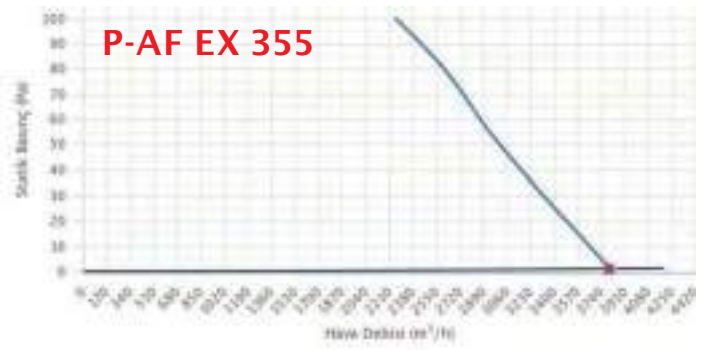
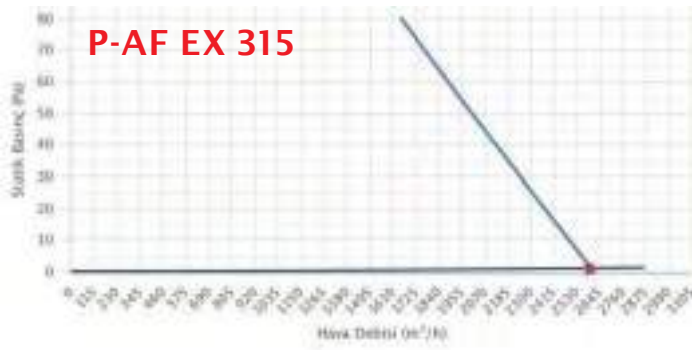

Axial Jet Fan

AJF



Utilization Areas



Description

- * Double speed motor
- * Aluminum blades
- * 300 °C/2h heat resistance
- * Silencer
- * Electrostatic Powder Coating
- * Protective wire mesh

Technical

Drawing

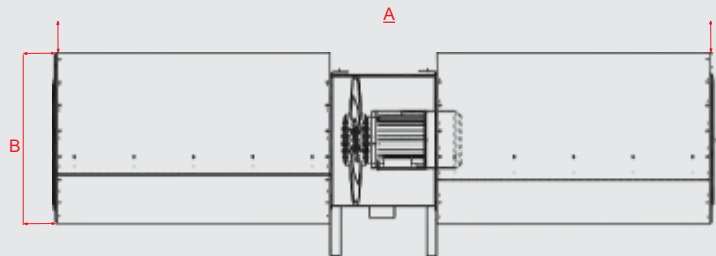
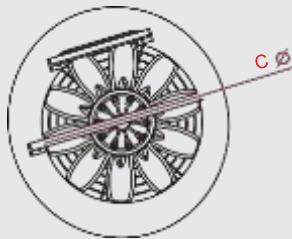

Technical Characteristics

55 °C

MODELS	FLOW (m³/h)	POWER (kW)	VOLTAGE (V)	ITME (N)	CURRENT (A)	SPEED (rpm)	FREQ. (Hz)	NOISE (dbA)	DIMENSIONS		
									A (mm)	B (mm)	C (mm)
P-AJF 315	2500-5000	0,70-0,85	380	7/26	2-2,3	1500-3000	50	39-58	1700	415	315
P-AJF 355	3500-7000	1-1,3	380	12/46	2,5-3,3	1500-3000	50	41-62	1700	515	355
P-AJF 400	5000-10000	1,3-1,8	380	19/76	3-4,3	1500-3000	50	44-65	1700	615	400

300 °C F 300 2 H

MODELS	FLOW (m³/h)	POWER (kW)	VOLTAGE (V)	ITME (N)	CURRENT (A)	SPEED (rpm)	FREQ. (Hz)	NOISE (dbA)	DIMENSIONS		
									A (mm)	B (mm)	C (mm)
P-AJF 315	2500-5000	0,25/1	380	7/26	0,70-2,2	1500-3000	50	39-58	1700	415	315
P-AJF 355	3500-7000	0,33/1,3	380	12/46	0,90-2,8	1500-3000	50	41-62	1700	515	355
P-AJF 400	5000-10000	0,5/2	380	19/76	1,2-4,2	1500-3000	50	44-65	1700	615	400

400 °C F 400

MODELS	FLOW (m³/h)	POWER (kW)	VOLTAGE (V)	ITME (N)	CURRENT (A)	SPEED (rpm)	FREQ. (Hz)	NOISE (dbA)	DIMENSIONS		
									A (mm)	B (mm)	C (mm)
P-AJF 315	2500-5000	0,25/1	380	7/26	0,70-2,2	1500-3000	50	70	1700	415	315
P-AJF 355	3500-7000	0,33/1,3	380	12/46	0,90-2,8	1500-3000	50	75	1700	515	355
P-AJF 400	5000-10000	0,5/2	380	19/76	1,2-4,2	1500-3000	50	79	1700	615	400

www.pointhvac.com

Radial Jet Fan

RJF



Utilization Areas



Description

- * Low noise level
- * Easy Application
- * Double Speed Motor
- * Compact Design
- * Protective Wire Mesh
- * EN 12101-3
- * Easy maintenance
- * 300 C/2h

Technical Drawing

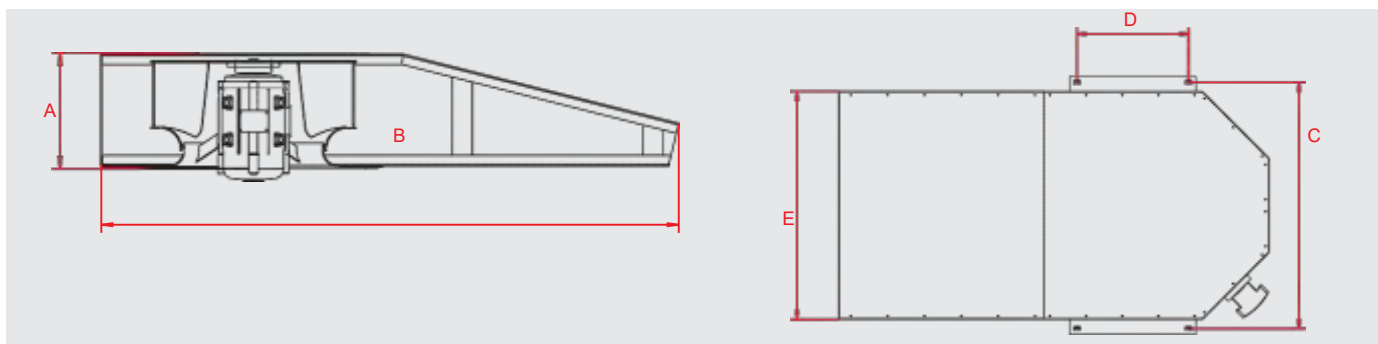

Technical Characteristics

MODELS	FLOW (m ³ /h)	POWER (kW)	VOLTAGE (V)	ITME (N)	SPEED (rpm)	FREQ. (Hz)	NOISE (dbA)	DIMENSIONS			D (mm)	E (mm)
								A (mm)	B (mm)	C (mm)		
P-RJF 500	2500-5000	0,3/1,2	380	12/48	750-1500	50	55-73	280	1400	900	370	800
P-RJF 560	3500-7000	0,55/2,2	380	18/69	750-1500	50	60-91	300	1410	1000	370	900

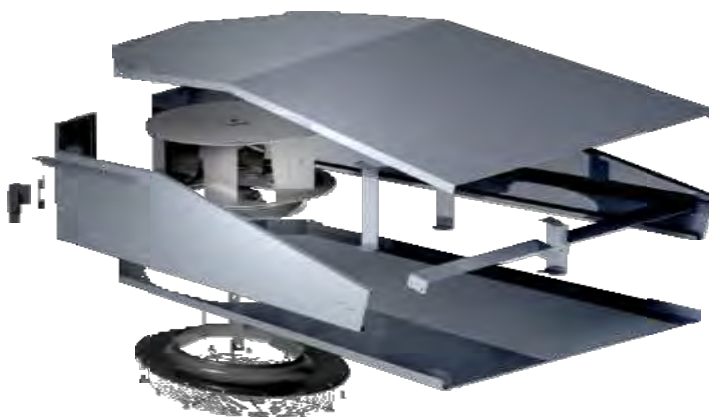

Dense Blade Cabinet/Cell Type Aspirator

SH



Utilization Areas



Description

- * Low noise level
- * Double wall panels
- * Double inlet centrifugal fan
- * Access Door
- * Electrostatic powder coating
- * G4 filter (Optional)
- * Sight Glass (Optional)
- * Volume damper (Optional)

Technical Drawing

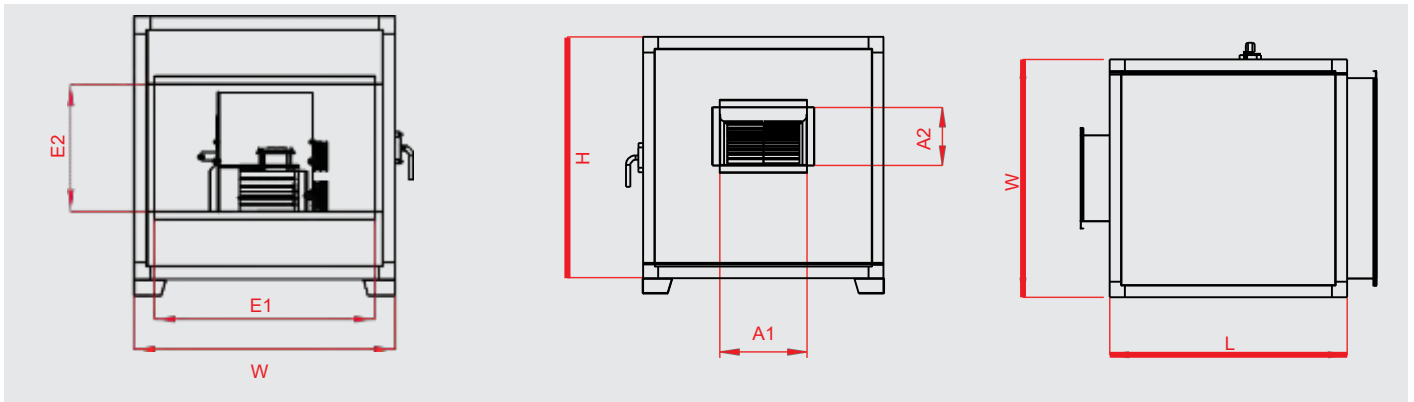

Yön Seçim Tablosu

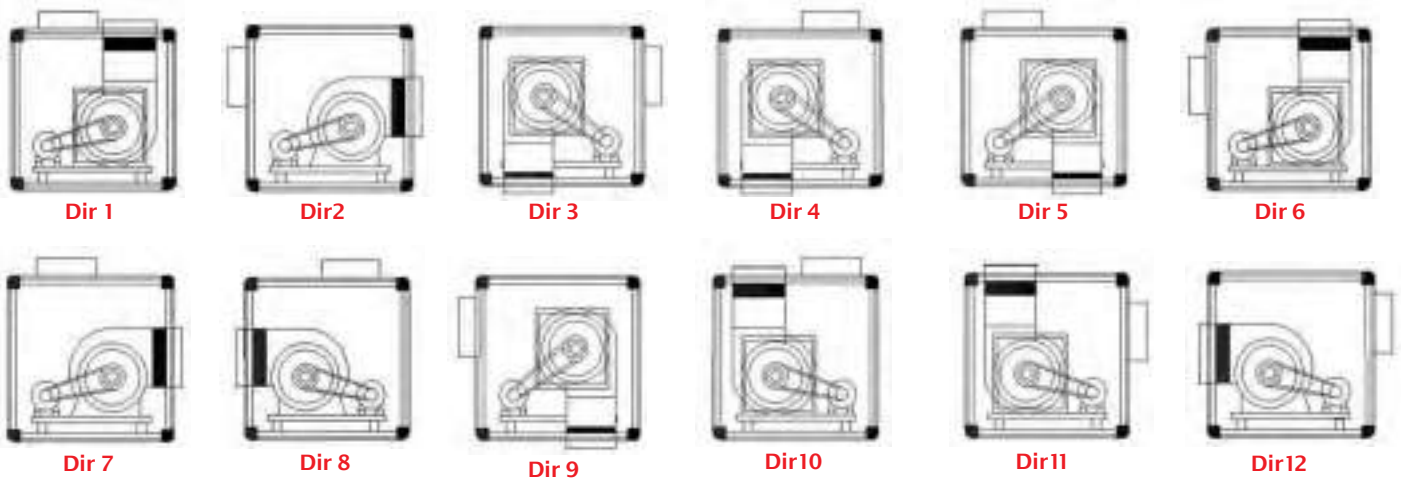

* Please indicate the direction at the order.

Technical Characteristics

MODELS	FLOW	PRESSURE (Toplam Statik)	FAN MODEL	MOTOR	SPEED	NOISE	EXT. WIDTH (W)	EXT. HEIGHT (H)	EXT. LENGTH (L)	INLET DIMENSIONS (E1 x E2)			OUTLET DIMENSIONS (A1 x A2)		
	(m ³ /h)	(pa)		(kW)	(rpm)	(dBa)	(mm)	(mm)	(mm)	(mm)			(mm)		
P-SH-11T	1000	300	7*7	0,25	1390	74,3	600	600	700	520	x	200	232	x	208
P-SH-17T	2000	500	7*7	0,75	1773	79,9	600	600	700	520	x	250	232	x	208
P-SH-23T	3000	500	9*9	1,1	1488	80,6	600	600	800	520	x	300	298	x	262
P-SH-29T	4000	500	9*9	1,5	1494	84,5	600	600	800	520	x	350	298	x	262
P-SH-35T	5000	500	10*10	1,5	1180	85	700	700	900	620	x	400	331	x	289
P-SH-41T	6000	500	12*12	2,2	1022	88,7	800	800	1000	720	x	450	395	x	341
P-SH-47T	7000	500	12*12	2,2	999	90,4	800	800	1000	720	x	450	395	x	341
P-SH-53T	8000	500	15*11	2,2	824	88,8	900	900	1100	820	x	500	373	x	404
P-SH-59T	9000	500	15*15	3	854	90,5	900	900	1100	820	x	500	471	x	404
P-SH-65T	10000	500	15*15	3	849	93,3	900	900	1100	820	x	500	471	x	404
P-SH-71T	11000	500	18*18	3	723	94,6	1100	1100	1200	1020	x	550	557	x	478
P-SH-77T	12000	500	18*18	3	723	92,5	1100	1100	1200	1020	x	550	557	x	478
P-SH-83T	13000	500	18*18	4	717	93,3	1100	1100	1200	1020	x	600	557	x	478
P-SH-89T	14000	500	18*18	4	713	93,3	1100	1100	1200	1020	x	550	557	x	478
P-SH-92T	15000	500	450	5,5	733	93,8	1200	1200	1400	1120	x	600	569	x	569
P-SH-98T	16000	500	450	5,5	732	97,4	1200	1200	1400	1120	x	600	569	x	569
P-SH-102T	17000	500	450	5,5	734	93,3	1200	1200	1400	1120	x	650	569	x	569
P-SH-107T	18000	500	500	5,5	684	93,5	1300	1300	1500	1220	x	700	638	x	638
P-SH-111T	19000	500	500	5,5	684	95,4	1300	1300	1500	1220	x	700	638	x	638
P-SH-115T	20000	500	500	5,5	685	93,1	1300	1300	1500	1220	x	750	638	x	638
P-SH-119T	21000	500	500	7,5	687	87,1	1300	1300	1500	1220	x	700	638	x	638
P-SH-123T	22000	500	500	7,5	691	87,1	1300	1300	1500	1220	x	700	638	x	638
P-SH-127T	23000	500	560	7,5	605	87,1	1400	1400	1700	1320	x	700	715	x	715
P-SH-131T	24000	500	560	7,5	605	87,1	1400	1400	1700	1320	x	750	715	x	715
P-SH-135T	25000	500	560	7,5	606	87,1	1400	1400	1700	1320	x	750	715	x	715
P-SH-139T	26000	500	560	7,5	607	87,1	1400	1400	1700	1320	x	750	715	x	715
P-SH-143T	27000	500	560	7,5	609	90	1400	1400	1700	1320	x	800	715	x	715
P-SH-147T	28000	500	630	7,5	522	93,6	1700	1700	1900	1620	x	800	801	x	801
P-SH-151T	29000	500	630	7,5	520	93,3	1700	1700	1900	1620	x	800	801	x	801
P-SH-154T	30000	500	630	11	518	90,8	1700	1700	1900	1620	x	800	801	x	801
P-SH-157T	31000	500	630	11	517	93,7	1700	1700	1900	1620	x	800	801	x	801
P-SH-160T	32000	500	630	11	516	91,8	1700	1700	1900	1620	x	800	801	x	801
P-SH-163T	33000	500	630	11	516	94	1700	1700	1900	1620	x	800	801	x	801
P-SH-166T	34000	500	630	11	516	91,7	1700	1700	1900	1620	x	800	801	x	801
P-SH-169T	35000	500	710	11	474	94,3	1800	1800	2000	1720	x	800	898	x	898
P-SH-172T	36000	500	710	11	473	93,6	1800	1800	2000	1720	x	850	898	x	898
P-SH-175T	37000	500	710	11	473	94,5	1800	1800	2000	1720	x	850	898	x	898
P-SH-178T	38000	500	710	11	473	96	1800	1800	2000	1720	x	850	898	x	898
P-SH-181T	39000	500	710	11	472	95,6	1800	1800	2000	1720	x	850	898	x	898
P-SH-184T	40000	500	710	11	472	96,2	1800	1800	2000	1720	x	850	898	x	898
P-SH-187T	41000	500	710	15	473	96,1	1800	1800	2000	1720	x	850	898	x	898
P-SH-190T	42000	500	710	15	473	87,6	1800	1800	2000	1720	x	850	898	x	898

* For intermediate models, please contact.

Performance Curves

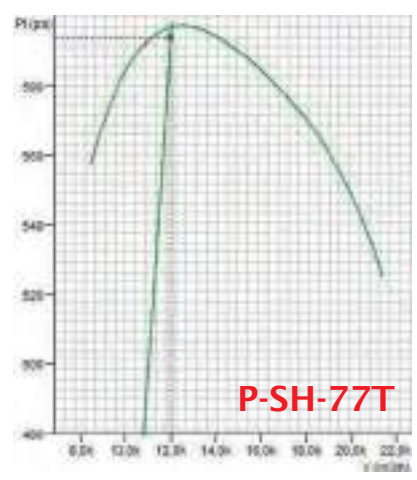
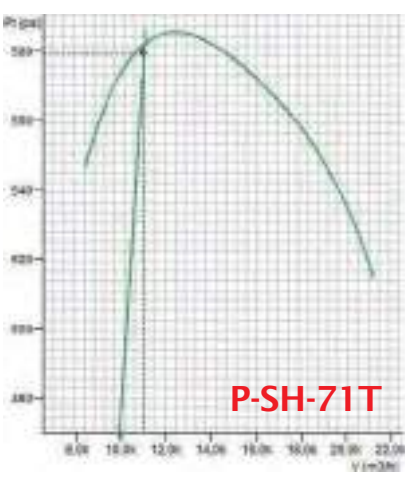
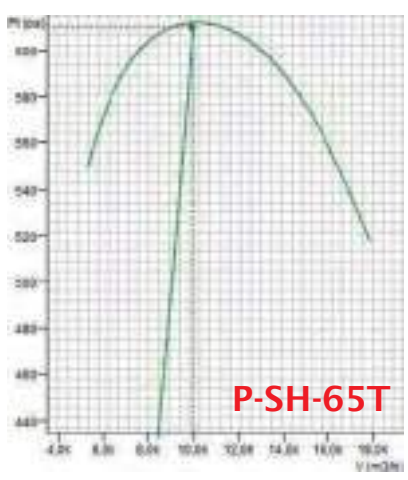
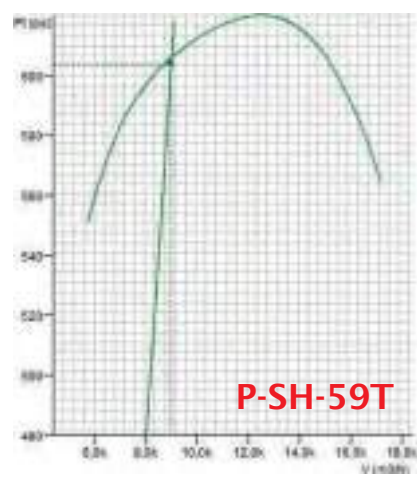
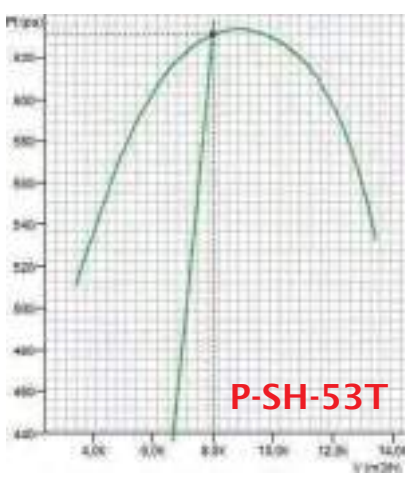
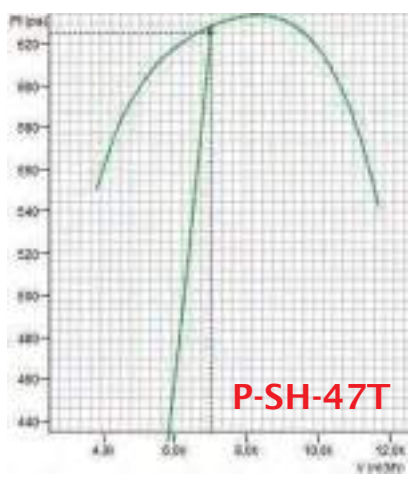
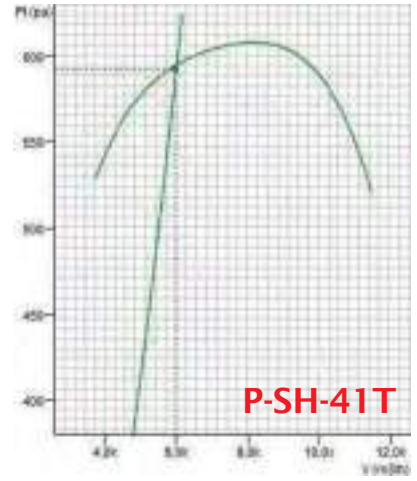
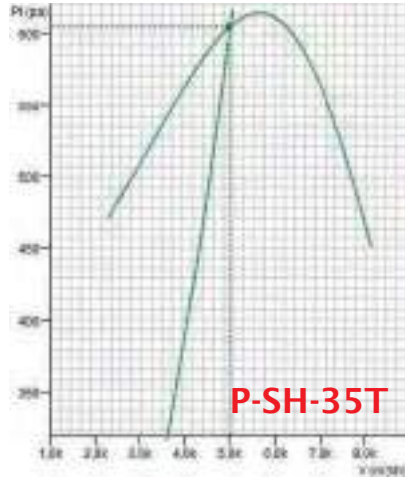
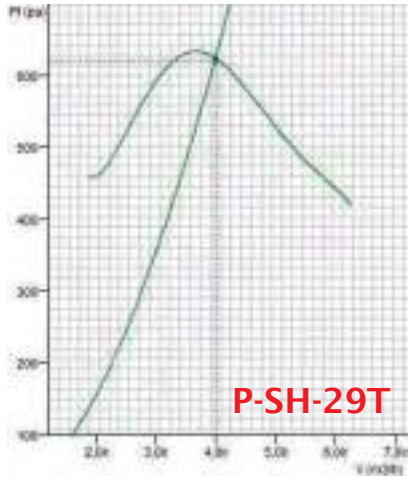
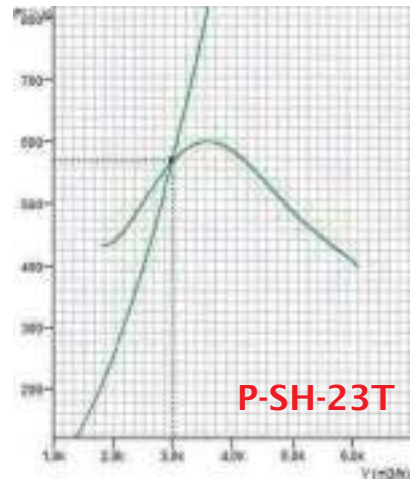
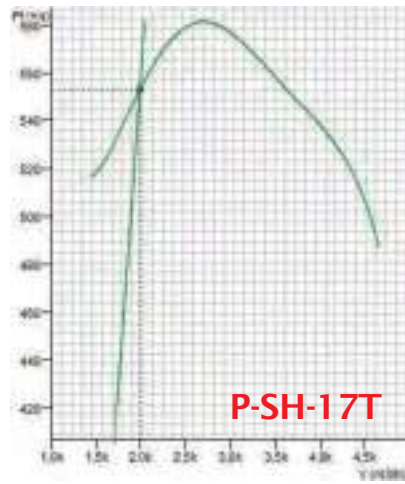

Performance Curves

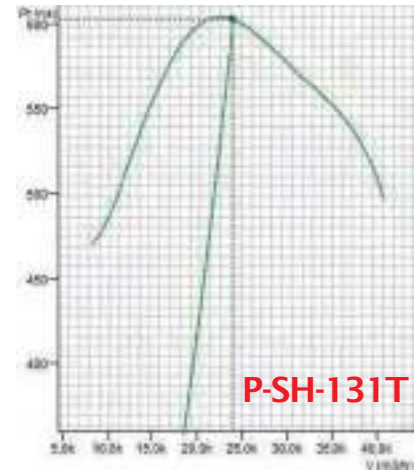
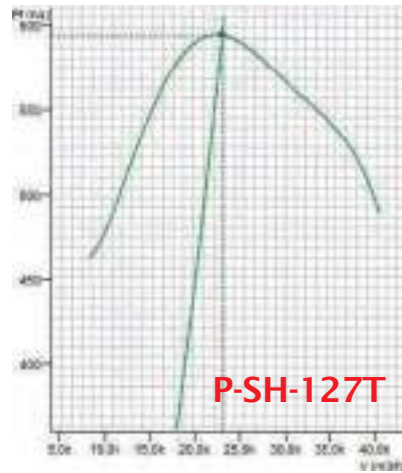
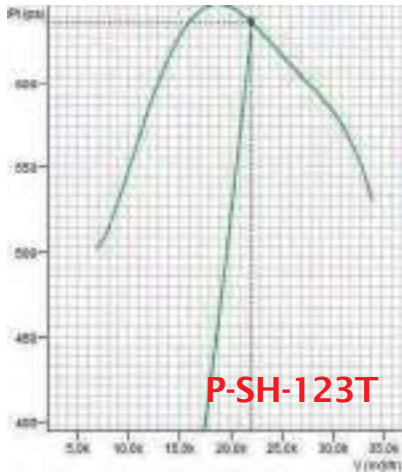
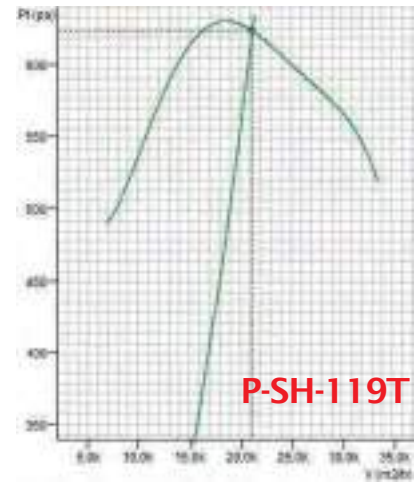
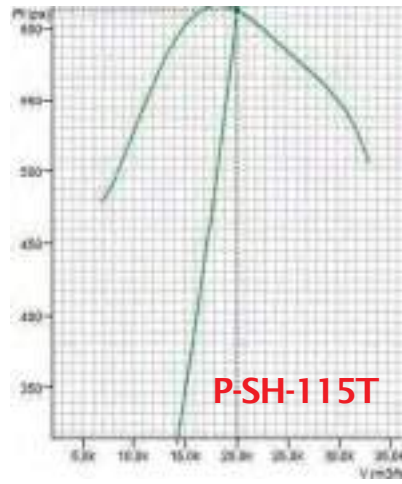
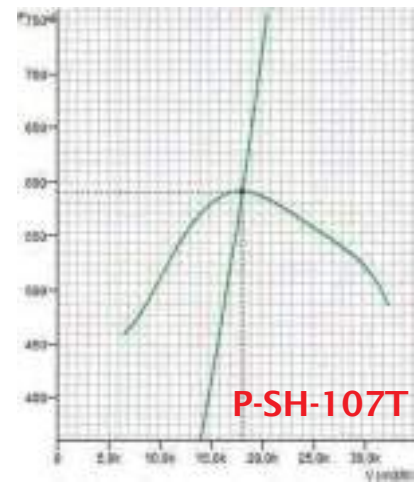
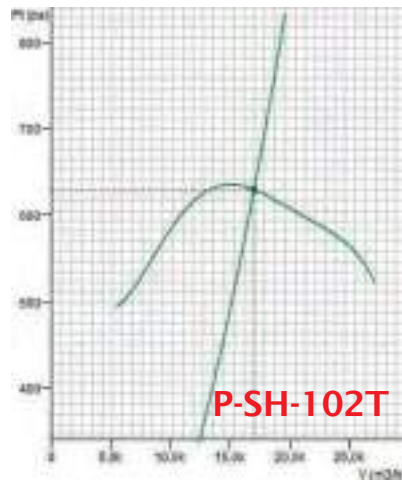
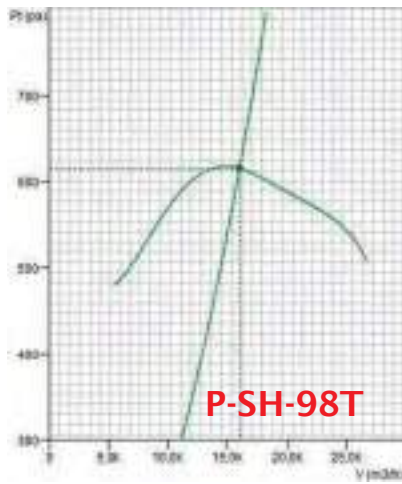
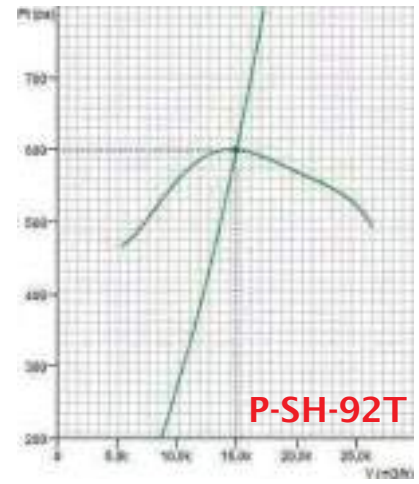
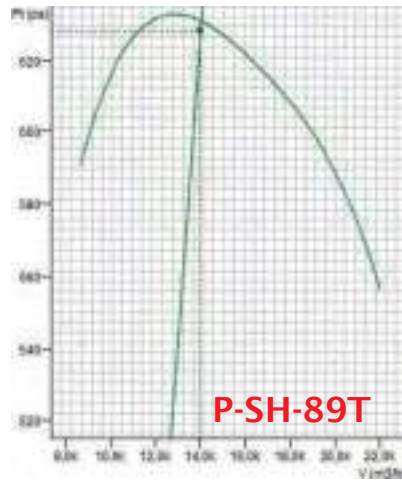
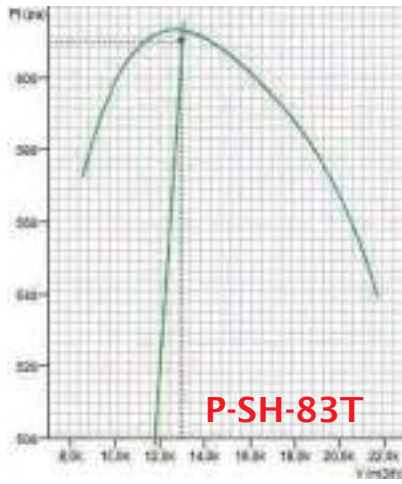

Performance Curves

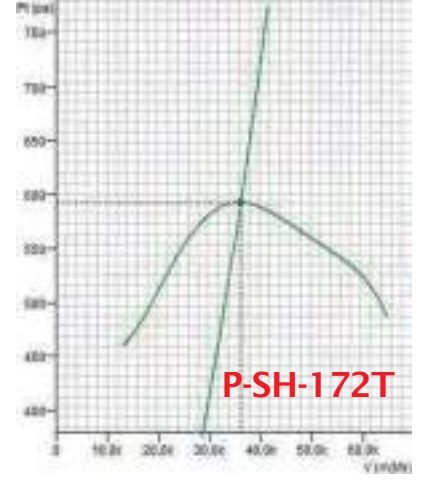
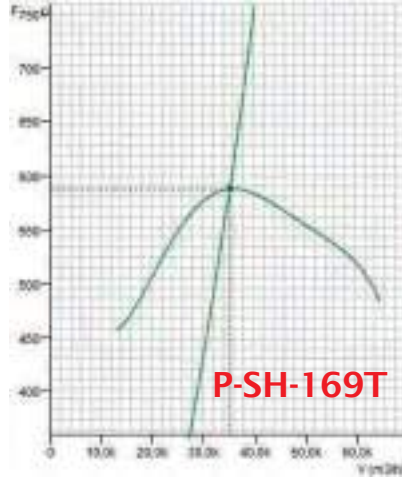
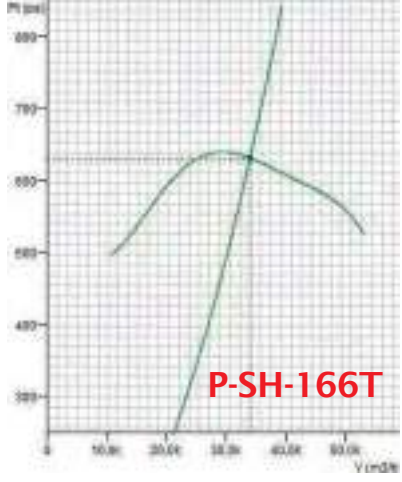
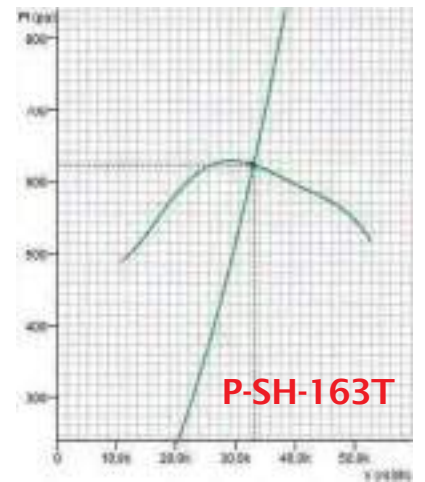
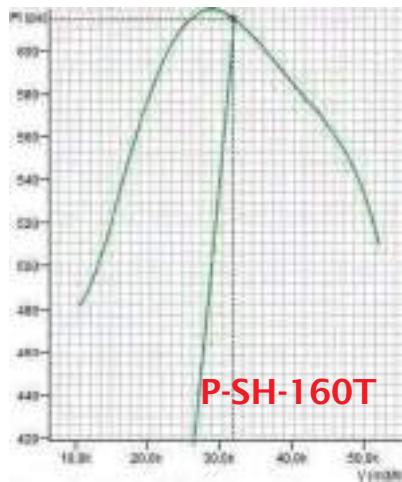
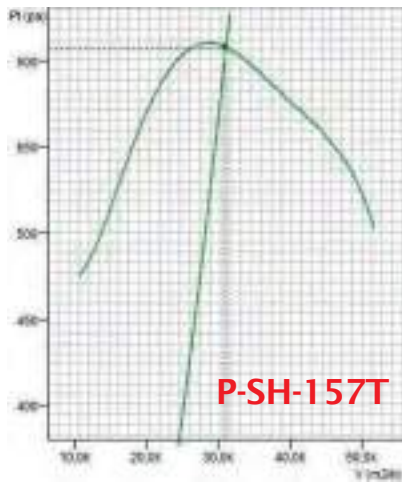
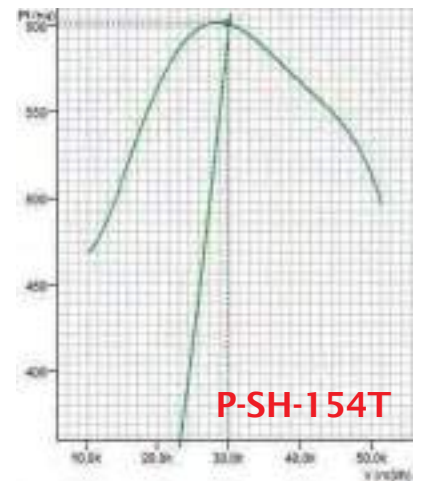
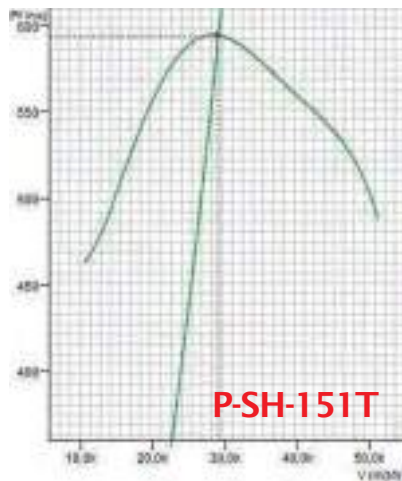
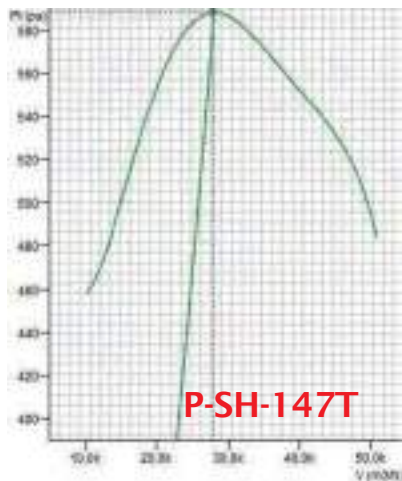
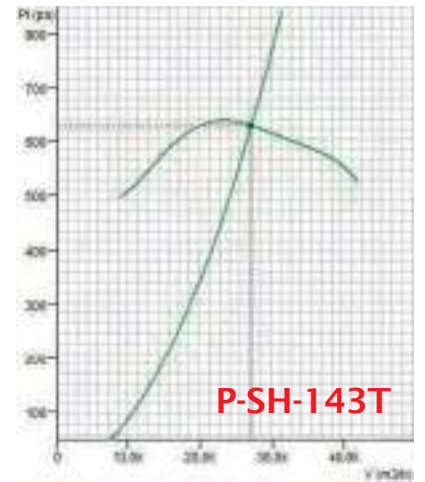
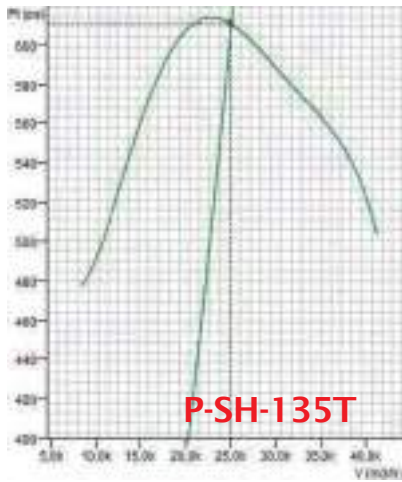

Performance Curves

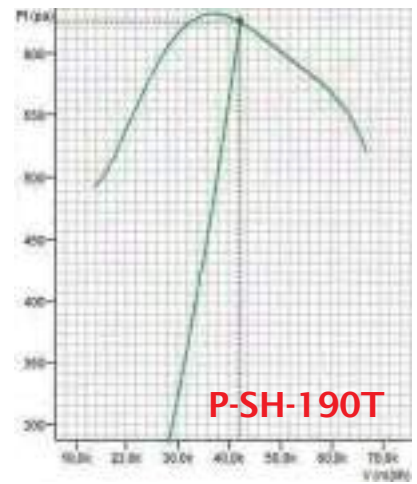
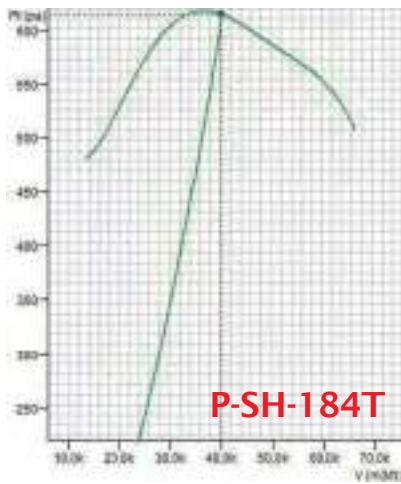
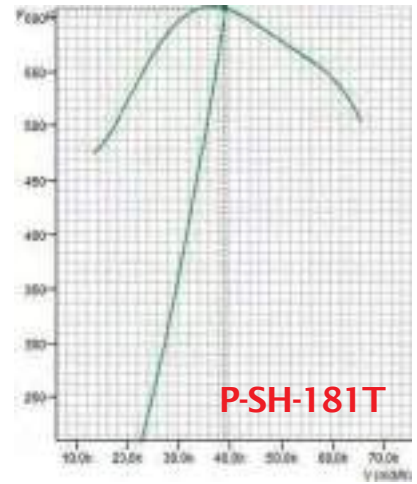
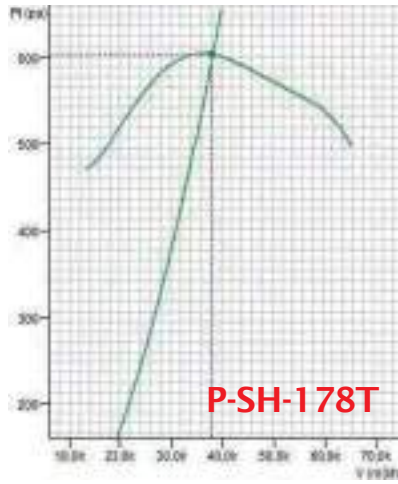
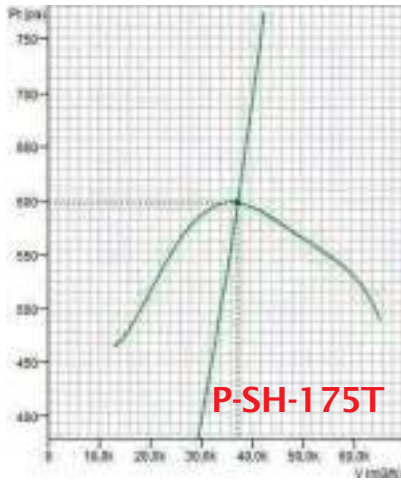

Rare Blade Cabinet/Cell Type Aspirator

SYH



Utilization Areas



Description

- * Emergency Stop Button
- * IP55 protection
- * Sight Glass(Optional)
- * Easy maintenance
- * Access Door
- * Low noise level
- * Highy Pressure Capacity
- * Oil Retain Filter

Technical Drawing

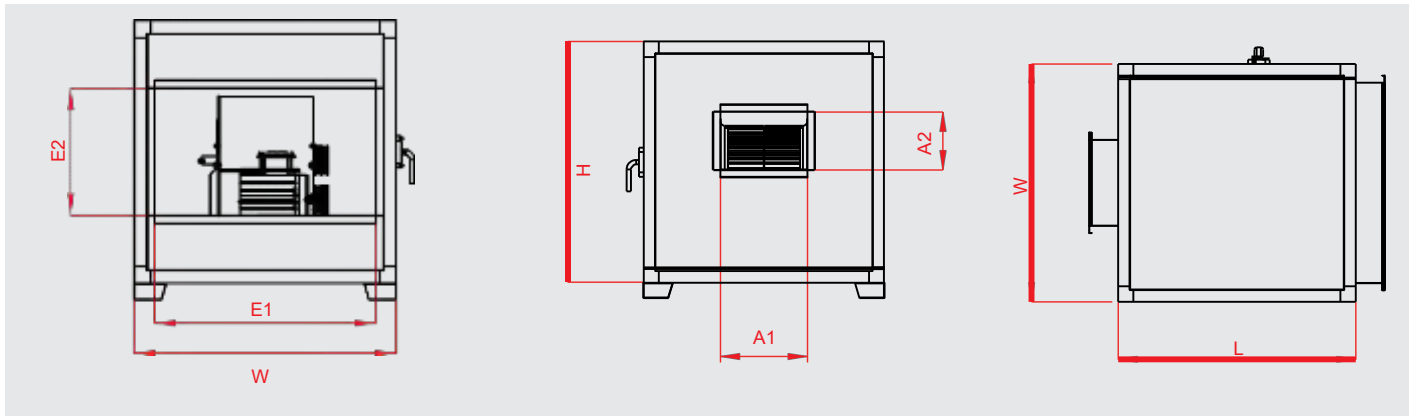

Direction Chart

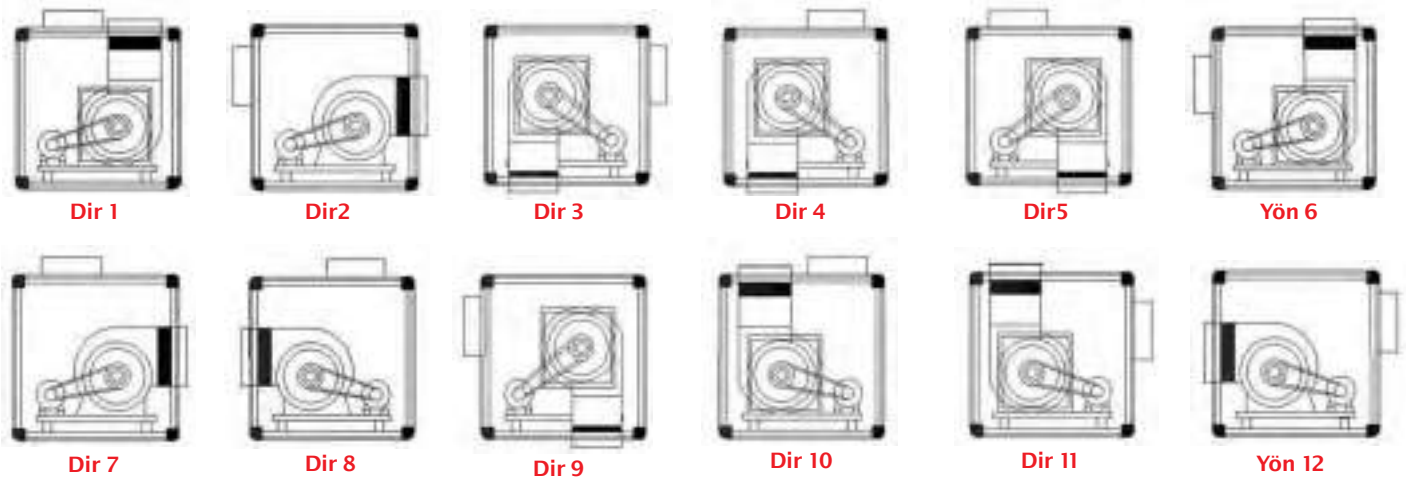

Technical Characteristics

MODELS	FLOW	PRESSURE (Toplam Statik)	FAN MODEL	MOTOR	SPEED	NOISE	EXT. WIDTH (W)	EXT. HEIGHT (H)	EXT. LENGTH (L)	INLET DIMENSIONSİ (E1 x E2)			OUTLET DIMENSIONSİ (A1 x A2)		
	(m³/h)	(pa)		(kW)	(rpm)	(dBa)	(mm)	(mm)	(mm)	(mm)			(mm)		
P-SYH-11T	2000	300	250	0,37	1902	77,6	700	700	900	620	x	200	322	x	322
P-SYH-16T	3000	500	250	1,1	2632	80,8	700	700	900	620	x	250	322	x	322
P-SYH-20T	4000	500	280	1,1	2296	86,7	800	800	1000	720	x	300	361	x	361
P-SYH-24T	5000	500	280	1,5	2663	90,3	800	800	1000	720	x	300	361	x	361
P-SYH-28T	6000	500	280	2,2	3043	90,5	800	800	1000	720	x	350	361	x	361
P-SYH-32T	7000	500	315	2,2	2476	92,9	900	900	1100	820	x	350	404	x	404
P-SYH-36T	8000	500	315	3	2770	94,7	900	900	1100	820	x	400	404	x	404
P-SYH-40T	9000	500	355	3	2134	97,5	1000	1000	1200	920	x	450	453	x	453
P-SYH-44T	10000	500	355	4	2358	95,4	1000	1000	1200	920	x	450	453	x	453
P-SYH-48T	11000	500	355	5,5	2671	97,9	1000	1000	1200	920	x	500	453	x	453
P-SYH-52T	12000	500	450	3	1519	99,7	1200	1200	1400	1120	x	550	569	x	569
P-SYH-56T	13000	500	400	5,5	2284	94,8	1100	1100	1300	1020	x	550	507	x	507
P-SYH-60T	14000	500	450	4	1650	97,2	1200	1200	1400	1120	x	550	569	x	569
P-SYH-64T	15000	500	450	5,5	1785	97,7	1200	1200	1400	1120	x	600	569	x	569
P-SYH-68T	16000	500	450	7,5	1915	94,7	1200	1200	1400	1120	x	600	569	x	569
P-SYH-72T	17000	500	450	7,5	1983	96,4	1200	1200	1400	1120	x	650	569	x	569
P-SYH-76T	18000	500	500	5,5	1508	97,1	1300	1300	1500	1220	x	650	638	x	638
P-SYH-80T	19000	500	500	7,5	1215	99,7	1300	1300	1500	1220	x	650	638	x	638
P-SYH-84T	20000	500	500	7,5	1673	94	1300	1300	1500	1220	x	650	638	x	638
P-SYH-88T	21000	500	500	11	1833	97,1	1300	1300	1500	1220	x	650	638	x	638
P-SYH-92T	22000	500	500	11	1887	97,3	1300	1300	1500	1220	x	700	638	x	638
P-SYH-96T	23000	500	560	7,5	1348	98,2	1400	1400	1700	1320	x	700	715	x	715
P-SYH-100T	24000	500	560	7,5	1437	96,3	1400	1400	1700	1320	x	700	715	x	715
P-SYH-104T	25000	500	560	11	1475	96,9	1400	1400	1700	1320	x	750	715	x	715
P-SYH-108T	26000	500	560	11	1610	99,2	1400	1400	1700	1320	x	750	715	x	715
P-SYH-112T	27000	500	560	11	1647	99,3	1400	1400	1700	1320	x	750	715	x	715
P-SYH-116T	28000	500	630	7,5	1152	99,4	1700	1700	1900	1620	x	800	801	x	801
P-SYH-120T	29000	500	630	7,5	1176	101	1700	1700	1900	1620	x	800	801	x	801
P-SYH-124T	30000	500	630	11	1291	101,2	1700	1700	1900	1620	x	800	801	x	801
P-SYH-128T	31000	500	630	11	1273	95,9	1700	1700	1900	1620	x	800	801	x	801
P-SYH-132T	32000	500	630	11	1300	96	1700	1700	1900	1620	x	800	801	x	801
P-SYH-136T	33000	500	630	15	1410	98,4	1700	1700	1900	1620	x	850	801	x	801
P-SYH-140T	34000	500	630	15	1436	98,5	1700	1700	1900	1620	x	850	801	x	801
P-SYH-144T	35000	500	710	11	1105	98,5	1800	1800	2000	1720	x	850	898	x	898
P-SYH-148T	36000	500	710	11	1035	98,6	1800	1800	2000	1720	x	850	898	x	898
P-SYH-152T	37000	500	710	11	1093	98,6	1800	1800	2000	1720	x	900	898	x	898
P-SYH-156T	38000	500	710	15	1111	96	1800	1800	2000	1720	x	900	898	x	898
P-SYH-160T	39000	500	710	15	1206	95,6	1800	1800	2000	1720	x	900	898	x	898
P-SYH-164T	40000	500	710	15	1149	96,6	1800	1800	2000	1720	x	950	898	x	898
P-SYH-168T	41000	500	710	15	1242	98,2	1800	1800	2000	1720	x	950	898	x	898
P-SYH-172T	42000	500	710	15	1206	96,6	1800	1800	2000	1720	x	950	898	x	898
P-SYH-176T	43000	500	710K	18,5	1278	98,8	1800	1800	2000	1720	x	950	898	x	898
P-SYH-180T	44000	500	710K	18,5	1297	98,9	1800	1800	2000	1720		950	898		898
P-SYH-184T	45000	500	710K	18,5	1315	99,1	1800	1800	2000	1720		1000	898		898
P-SYH-188T	46000	500	710K	22	1334	99,1	1800	1800	2000	1720		1000	898		898
P-SYH-192T	47000	500	710K	22	1353	99,3	1800	1800	2000	1720		1000	898		898
P-SYH-196T	48000	500	800K	15	983	96,1	2000	2000	2200	1920		1000	1007		1007
P-SYH-200T	49000	500	800K	15	996	96,5	2000	2000	2200	1920		1050	1007		1007
P-SYH-204T	50000	500	800K	15	1009	96,8	2000	2000	2200	1920		1050	1007		1007

* For intermediate models, please contact.

Performance Curves

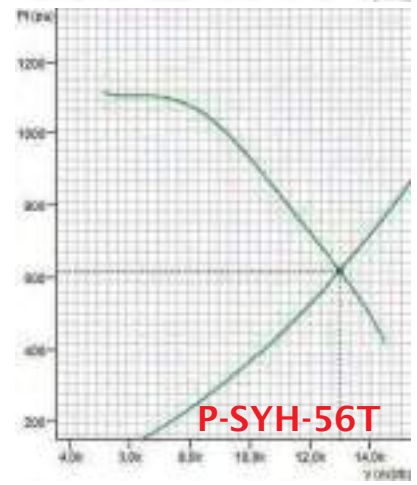
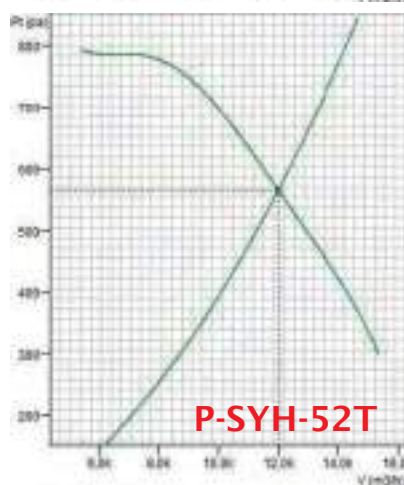
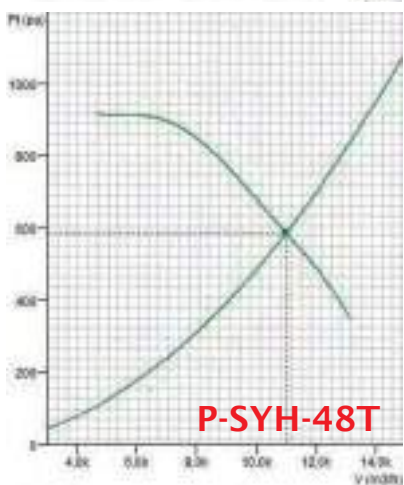
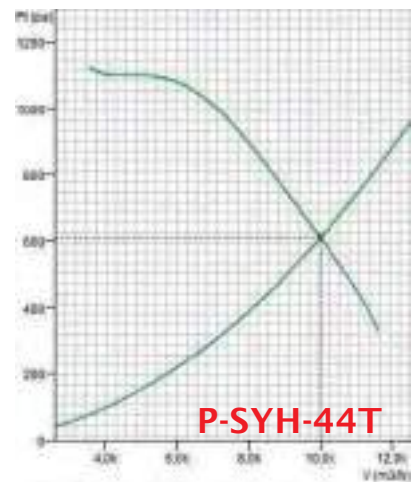
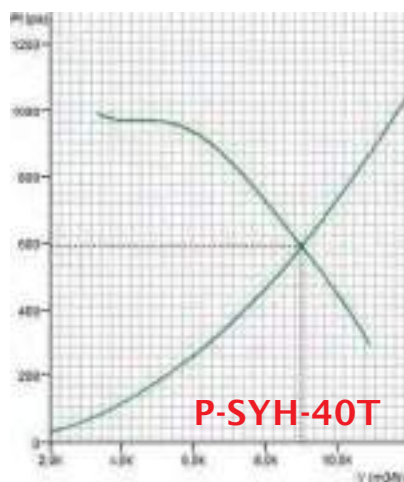
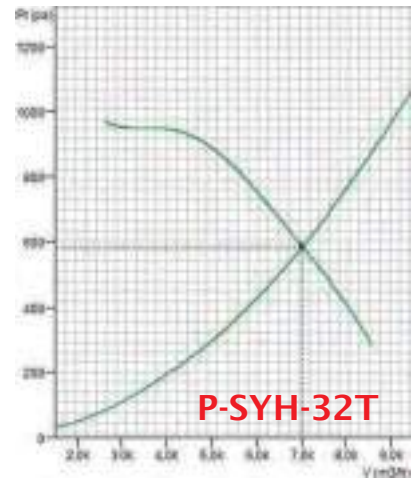
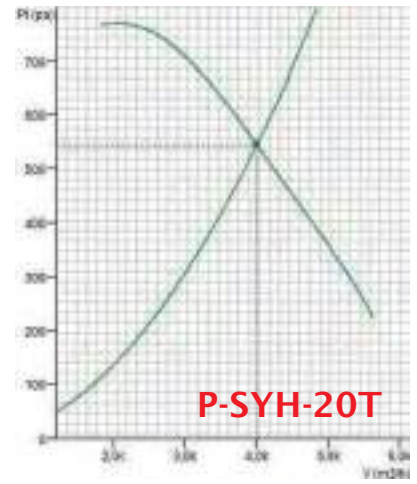
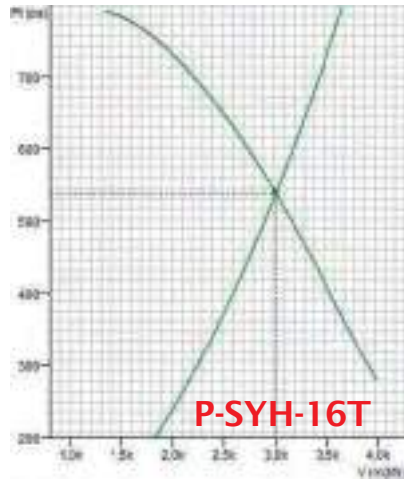

Performance Curves

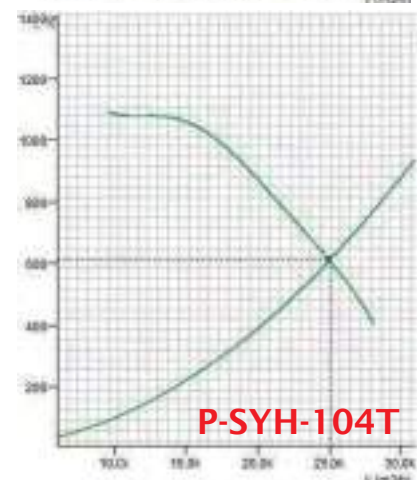
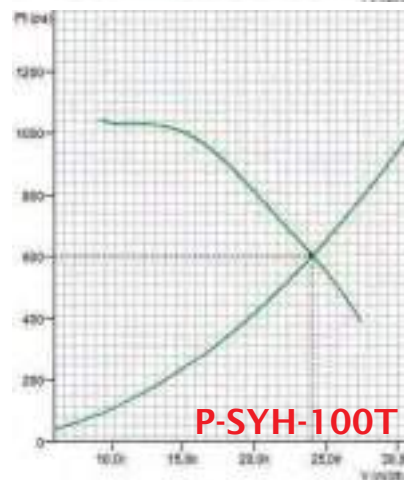
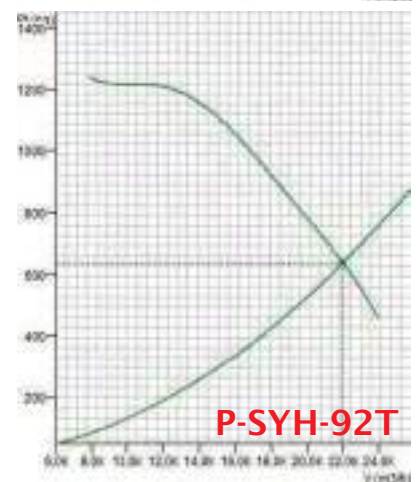
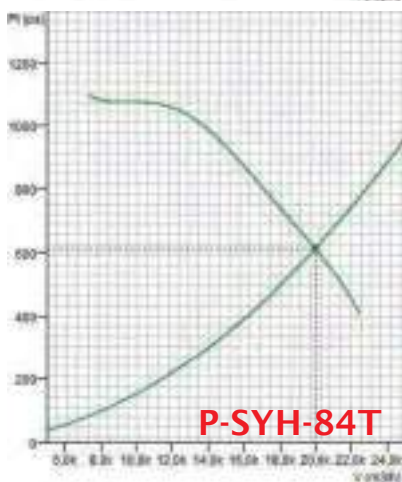
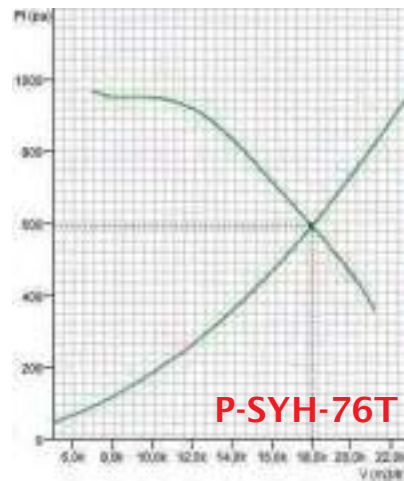
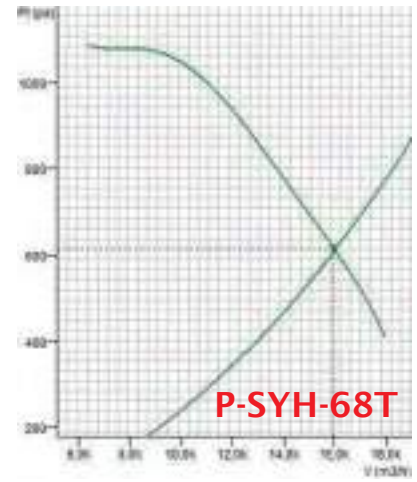
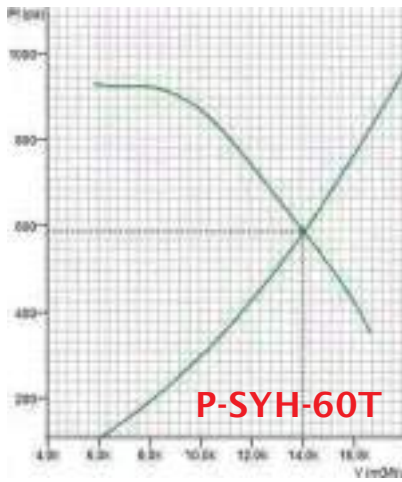

Performance Curves

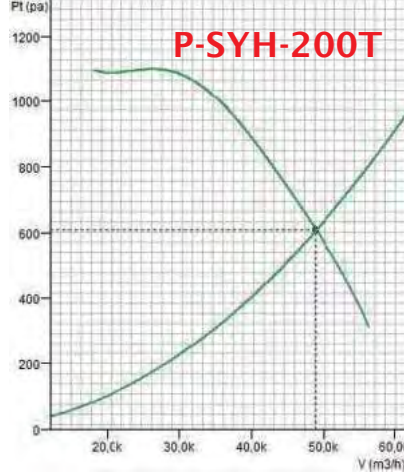
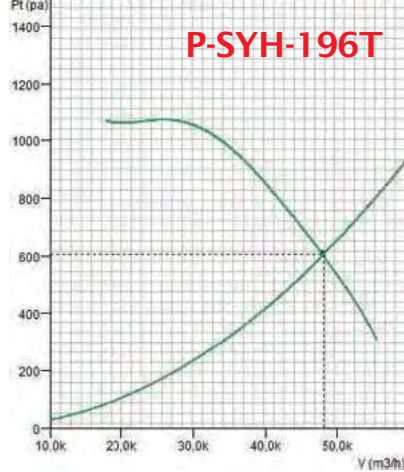
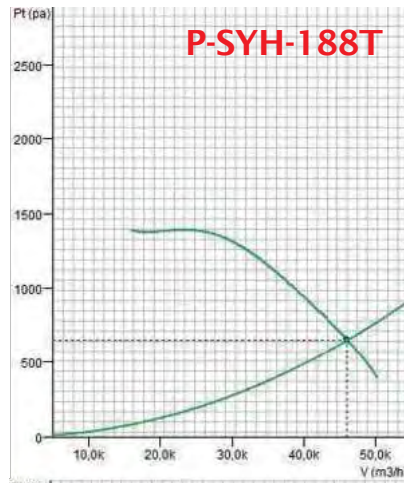
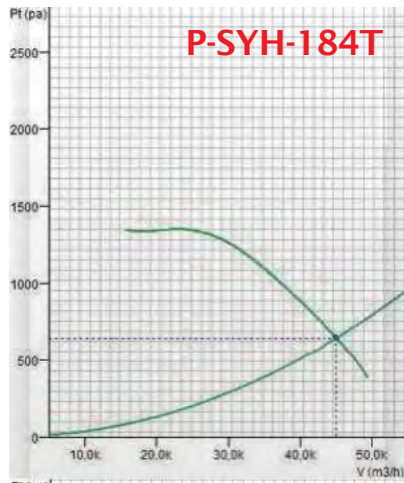
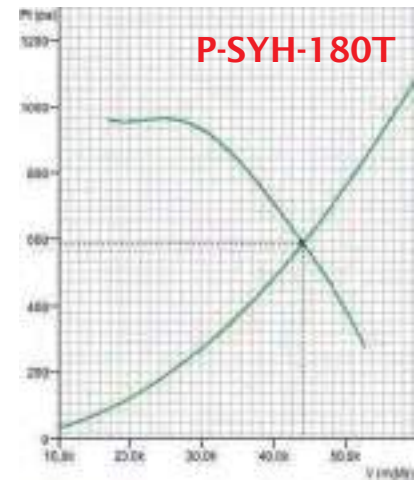
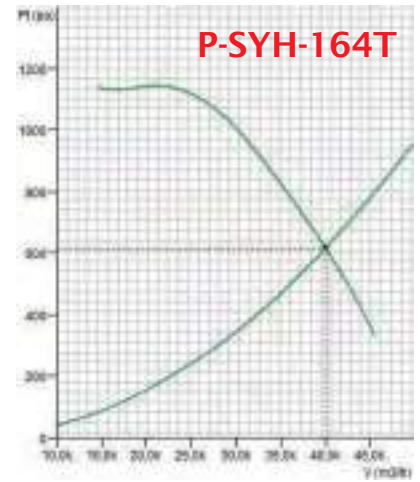
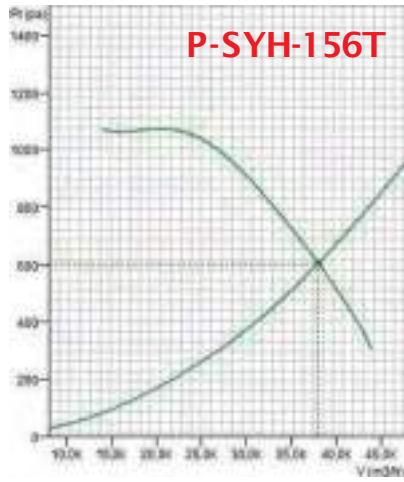

Cabinet/Cell Type Aspirator Pug Fan

PH



Utilization Areas



Description

- * IP55 protection
- * Emer.Start-Stop Button
- * Sight Glass
- * Easy maintenance
- * High Pressure Capacity
- * Metal Oil Retaining Filter (Optional)

Technical Drawing

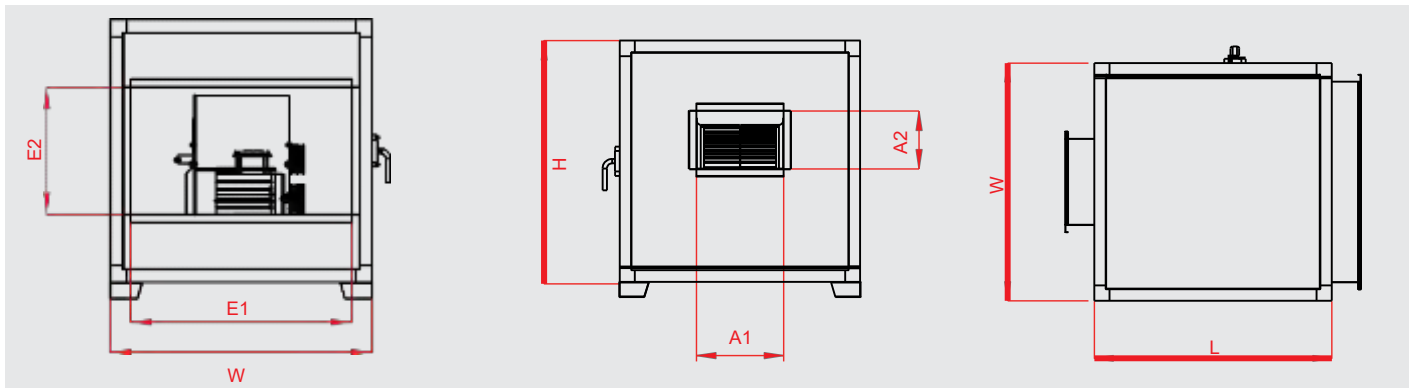

Direction Selection Table

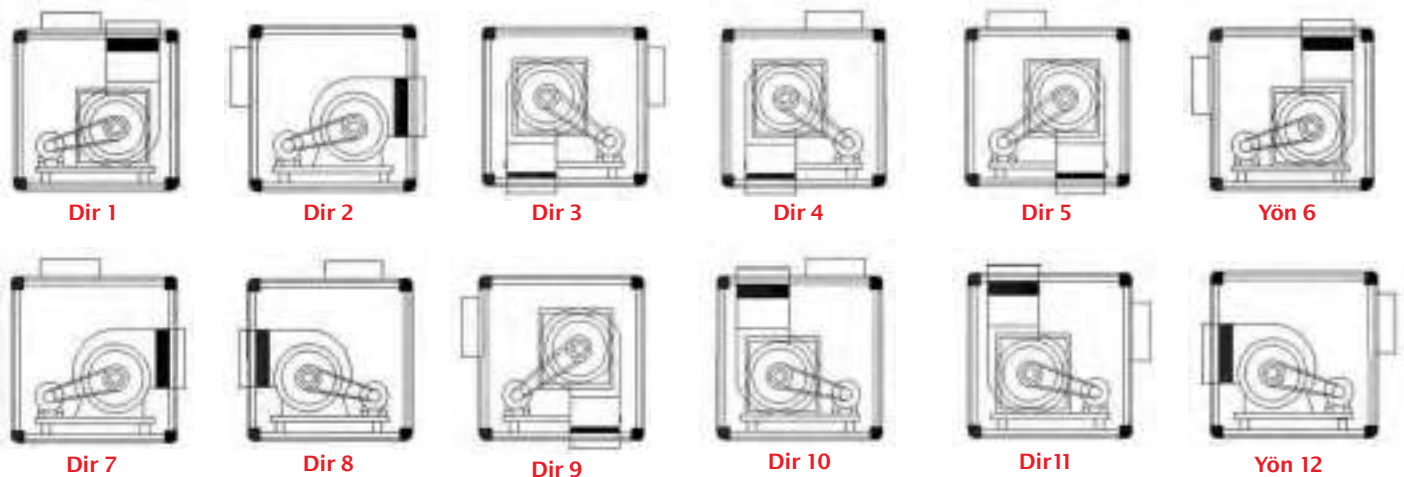

* Please indicate the direction at the order

Technical Characteristics

MODELS	FLOW	PRESSURE (Toplam Statik)	FAN MODEL	MOTOR	SPEED	NOISE	EXT. WIDTH (W)	EXT. HEIGHT (H)	EXT. LENGTH (L)	INLET DIMENSIONSİ (E1 x E2)			OUTLET DIMENSIONSİ (A1 x A2)		
	(m³/h)	(pa)		(kW)	(rpm)	(dBa)	(mm)	(mm)	(mm)	(mm)			(mm)		
P-PH-11T	2000	300	280	0,55	2538	88	650	650	1100	570	x	250	570	x	250
P-PH-16T	3000	500	280	1,1	3123	94	650	650	1100	570	x	300	570	x	300
P-PH-20T	4000	500	315	1,5	2880	96	700	700	1100	620	x	350	620	x	350
P-PH-24T	5000	500	355	2,2	2450	96	800	800	1100	720	x	450	720	x	450
P-PH-28T	6000	500	400	2,2	2111	101	900	900	1150	820	x	450	820	x	450
P-PH-32T	7000	500	400	3	2345	93	900	900	1150	820	x	450	820	x	450
P-PH-36T	8000	500	450	2,2	1945	103	1000	1000	1150	920	x	450	920	x	450
P-PH-40T	9000	500	450	3	2112	98	1000	1000	1150	920	x	500	920	x	500
P-PH-44T	10000	500	500	3	1783	96	1100	1100	1200	1020	x	550	1020	x	550
P-PH-48T	11000	500	500	4	1907	99	1100	1100	1200	1020	x	600	1020	x	600
P-PH-52T	12000	500	560	4	1550	96	1200	1200	1250	1120	x	600	1120	x	600
P-PH-56T	13000	500	560	4	1636	98	1200	1200	1250	1120	x	600	1120	x	600
P-PH-60T	14000	500	560	5,5	1725	100	1200	1200	1350	1120	x	650	1120	x	650
P-PH-64T	15000	500	630	5,5	1374	101	1350	1350	1350	1270	x	650	1270	x	650
P-PH-68T	16000	500	630	5,5	1434	103	1350	1350	1350	1270	x	700	1270	x	700
P-PH-72T	17000	500	630	5,5	1496	100	1350	1350	1350	1270	x	700	1270	x	700
P-PH-76T	18000	500	630	5,5	1560	101	1350	1350	1350	1270	x	700	1270	x	700
P-PH-80T	19000	500	710	5,5	1192	102	1500	1500	1400	1420	x	700	1420	x	700
P-PH-84T	20000	500	710	5,5	1231	103	1500	1500	1400	1420	x	750	1420	x	750
P-PH-88T	21000	500	710	7,5	1271	105	1500	1500	1550	1420	x	750	1420	x	750
P-PH-92T	22000	500	710	7,5	1313	98	1500	1500	1400	1420	x	800	1420	x	800
P-PH-96T	23000	500	710	7,5	1355	99	1500	1500	1400	1420	x	800	1420	x	800
P-PH-100T	24000	500	800	7,5	1064	100	1700	1700	1600	1620	x	850	1620	x	850
P-PH-104T	25000	500	800	7,5	1092	101	1700	1700	1600	1620	x	850	1620	x	850
P-PH-108T	26000	500	800	7,5	1121	102	1700	1700	1600	1620	x	900	1620	x	900
P-PH-112T	27000	500	800	7,5	1150	103	1700	1700	1600	1620	x	900	1620	x	900
P-PH-116T	28000	500	800	11	1179	104	1700	1700	1600	1620	x	900	1620	x	900
P-PH-120T	29000	500	800	11	1209	105	1700	1700	1600	1620	x	900	1620	x	900
P-PH-124T	30000	500	900	11	942	106	1900	1900	1700	1820	x	950	1820	x	950
P-PH-128T	31000	500	900	11	961	107	1900	1900	1700	1820	x	950	1820	x	950
P-PH-132T	32000	500	900	11	981	107	1900	1900	1700	1820	x	1000	1820	x	1000
P-PH-136T	33000	500	900	11	1002	108	1900	1900	1700	1820	x	1000	1820	x	1000
P-PH-140T	34000	500	900	11	1022	104	1900	1900	1700	1820	x	1000	1820	x	1000
P-PH-144T	35000	500	900	11	1043	105	1900	1900	1700	1820	x	1000	1820	x	1000
P-PH-148T	36000	500	900	11	1064	105	1900	1900	1700	1820	x	1050	1820	x	1050
P-PH-152T	37000	500	1000	11	859	106	2100	2100	1850	2020	x	1050	2020	x	1050
P-PH-156T	38000	500	1000	11	873	107	2100	2100	1850	2020	x	1050	2020	x	1050
P-PH-160T	39000	500	1000	11	888	107	2100	2100	1850	2020	x	1050	2020	x	1050
P-PH-164T	40000	500	1000	15	903	108	2100	2100	1850	2020	x	1100	2020	x	1100

Please contact for intermediate models.

Performance Curves

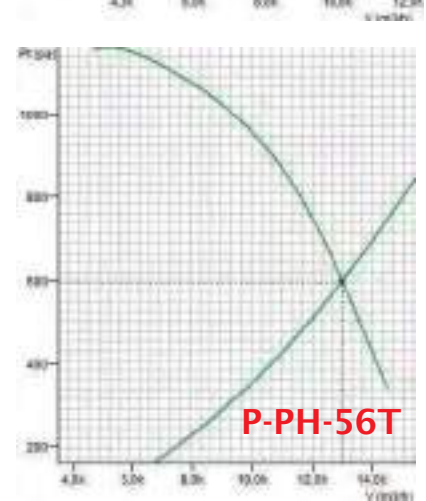
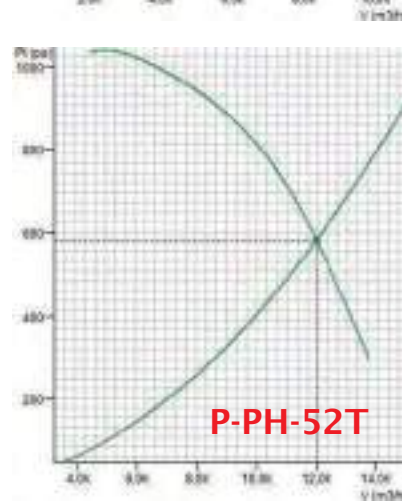
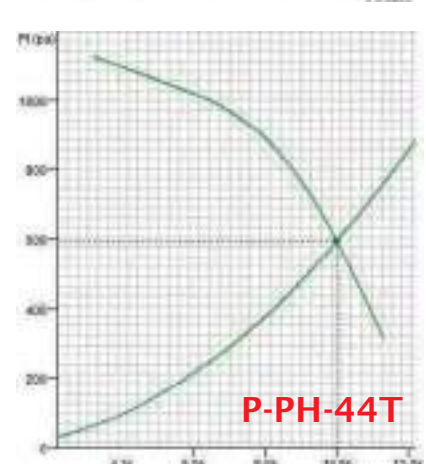
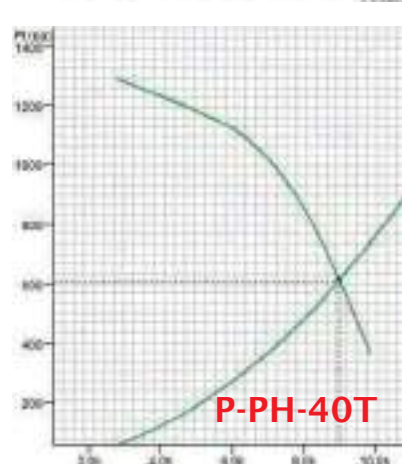
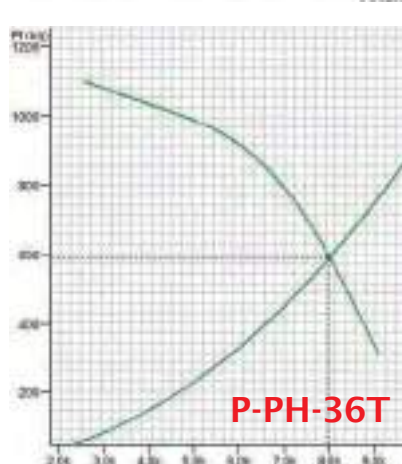
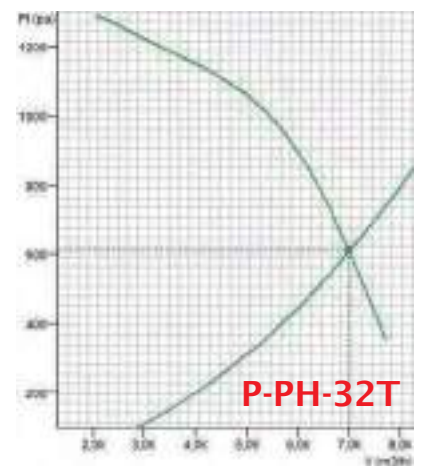
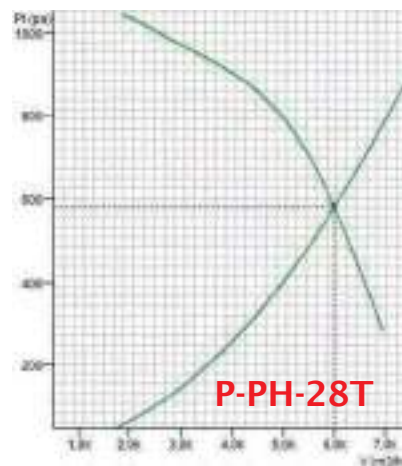
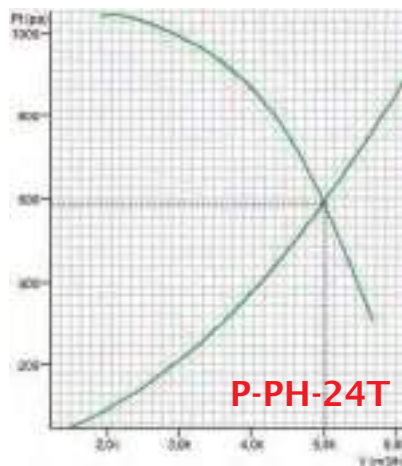
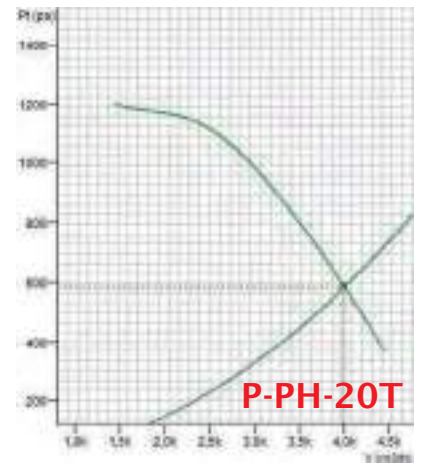
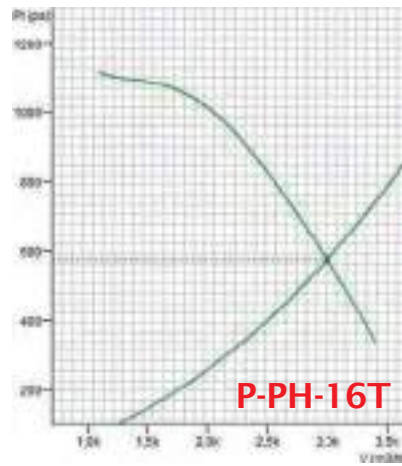
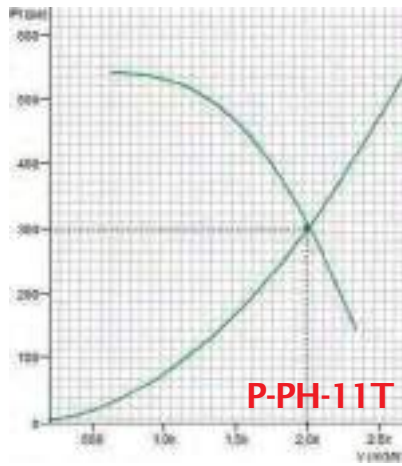

Performance Curves

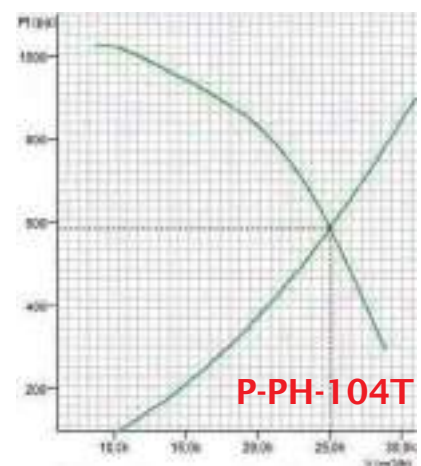
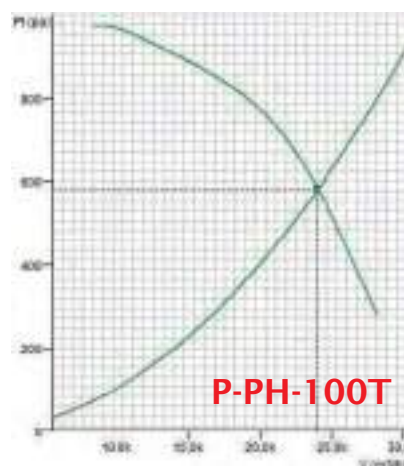
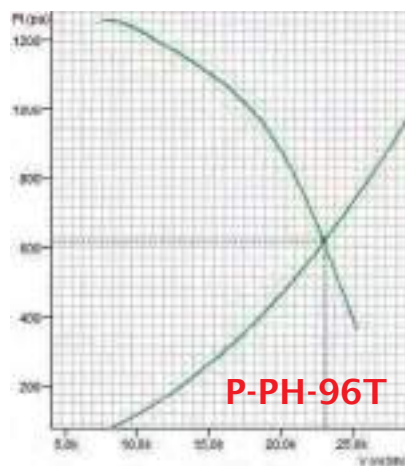
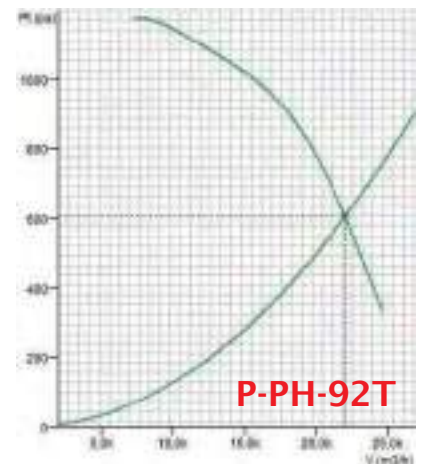
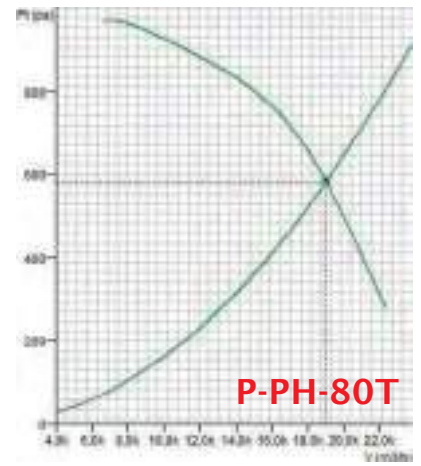
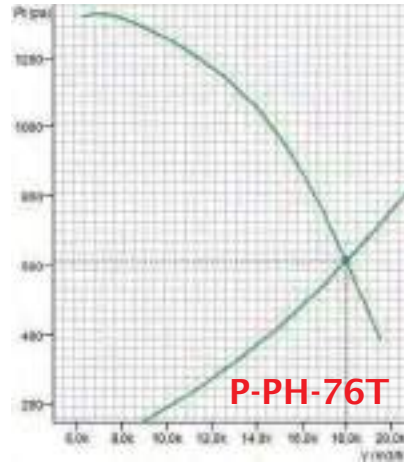
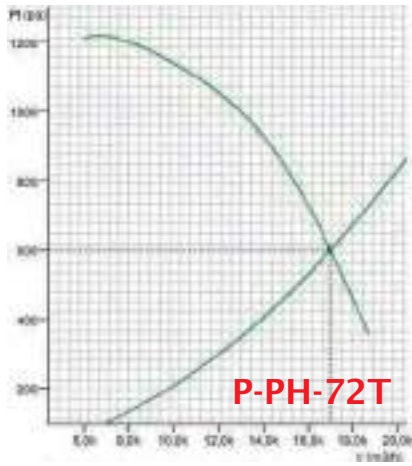
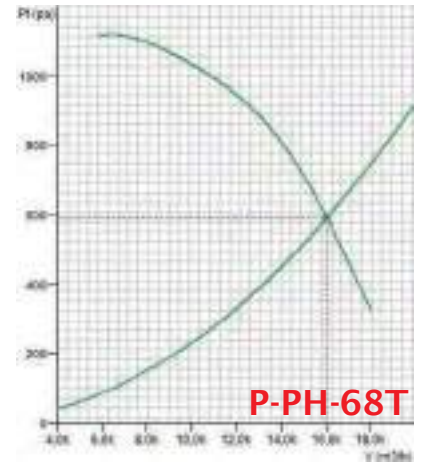
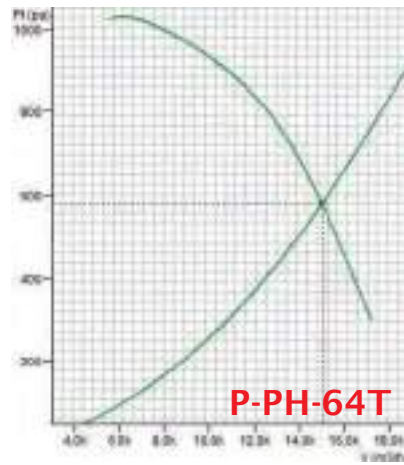
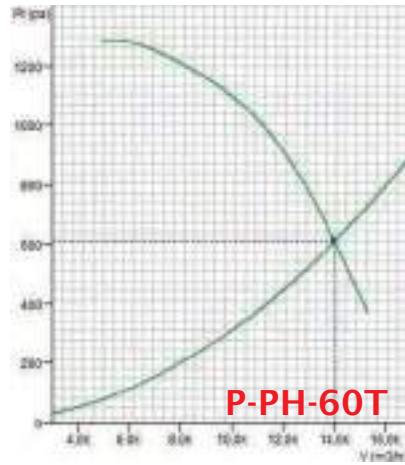

Performance Curves

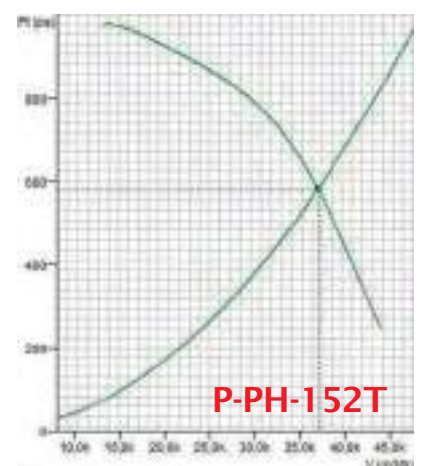
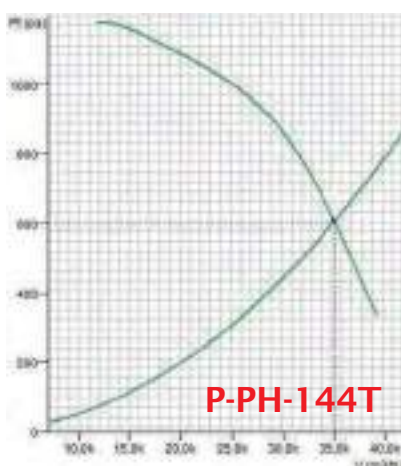
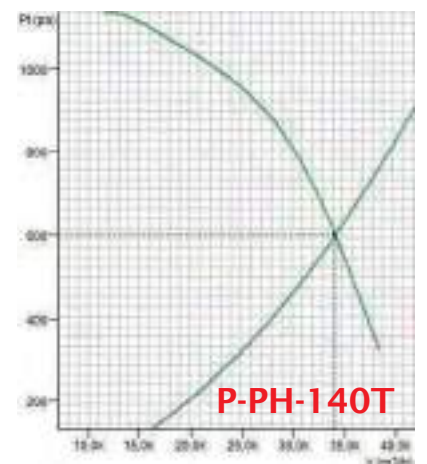
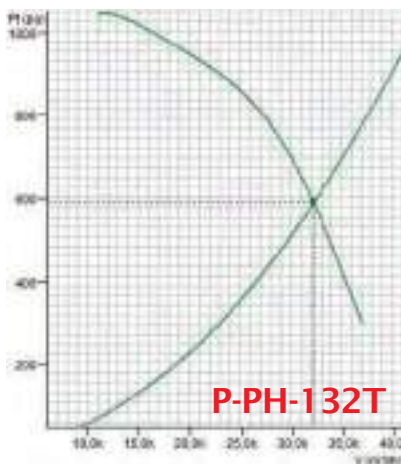
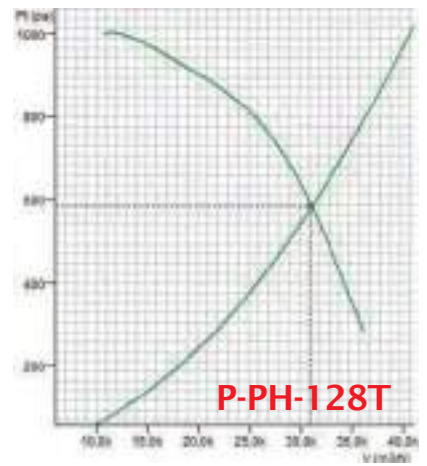
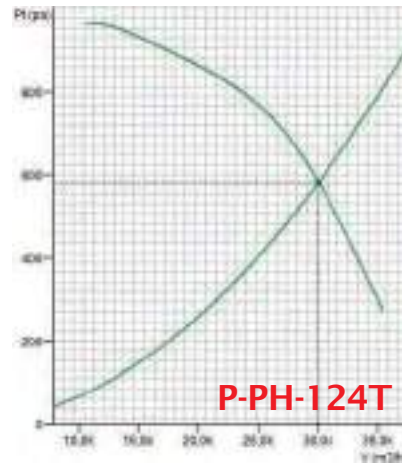
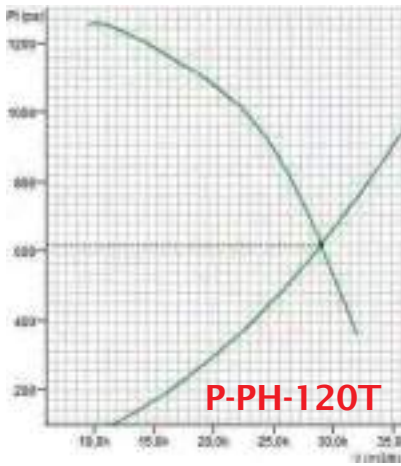
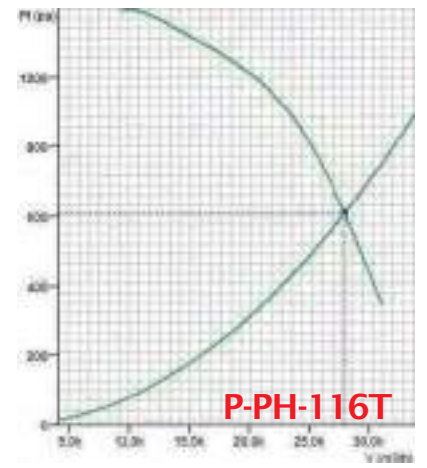
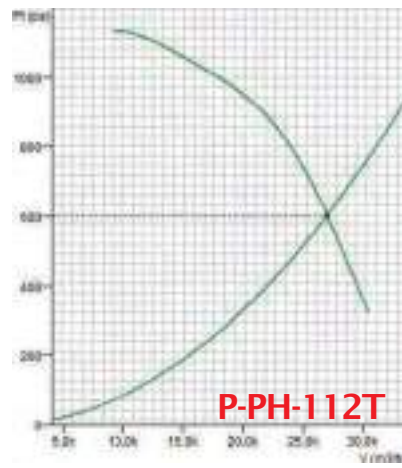
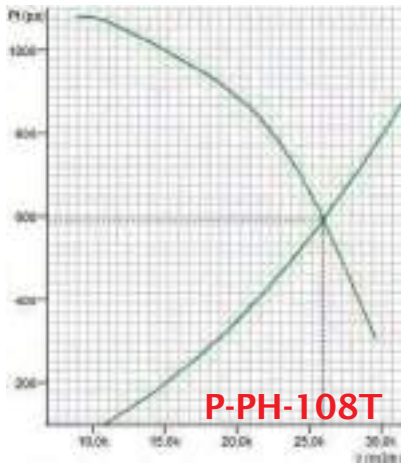

Performance Curves

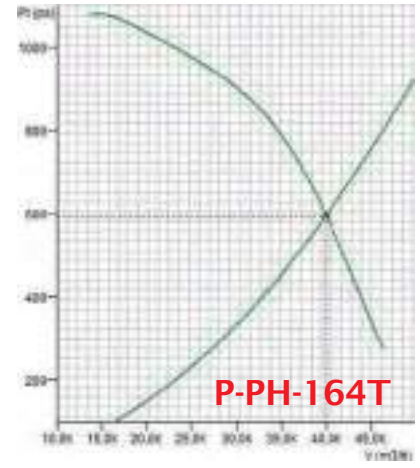
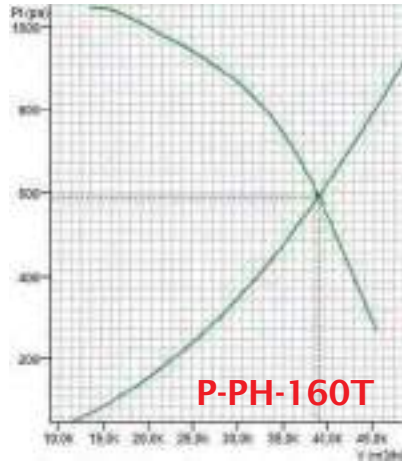

Kitchen Hood Fan

MDF



Utilization Areas



Description

- *Easy cleaning and maintenance
- *Double wal panels
- *Direct Drive Plug Fan
- *IP55 protection
- *Access Door
- *Easy Installation

Technical Drawing

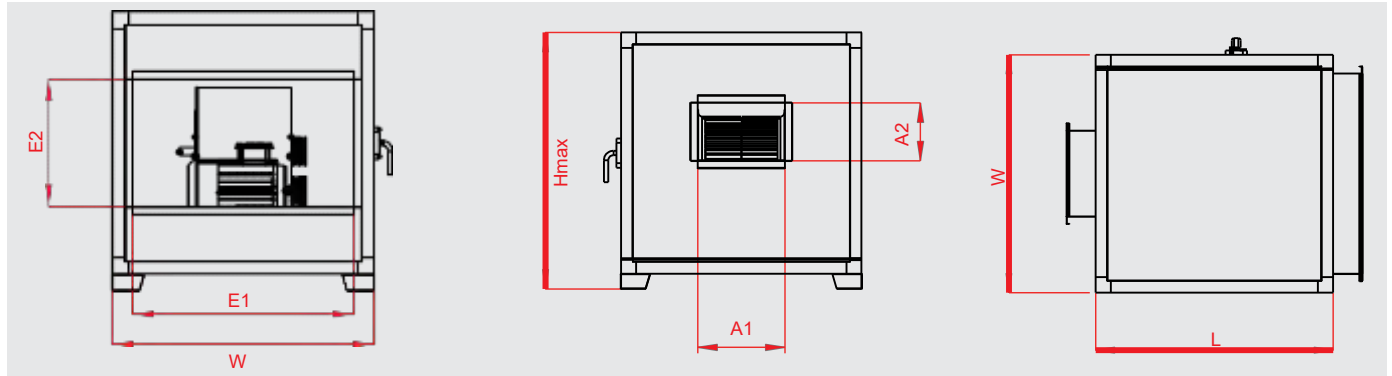

Technical Characteristics

MODELS	FLOW (m ³ /h)	POWER (kW)	VOLTAGE (V)	SPEED (rpm)	FREQ. (Hz)	NOISE (dbA)	A (mm)	DIMENSIONS B (mm)	C (mm)
P-MDF 3000	3000	0,25	230	1450	50	40	850	680	680
P-MDF 4000	4000	0,37	230	1450	50	43	850	780	780
P-MDF 5000	5000	0,55	230	1450	50	47	1030	930	930
P-MDF 7500	7500	1,1	230	1450	50	51	1030	980	980
P-MDF 10000	10000	2,2	230	1450	50	54	1230	1080	1080

Yön Seçim Tablosu

* Please indicate the at the order

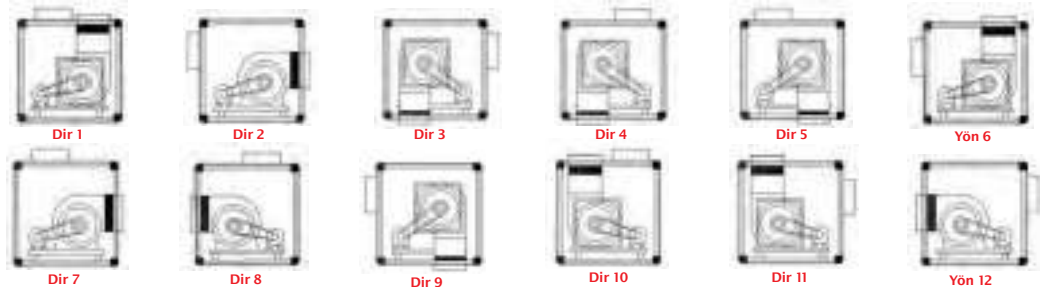

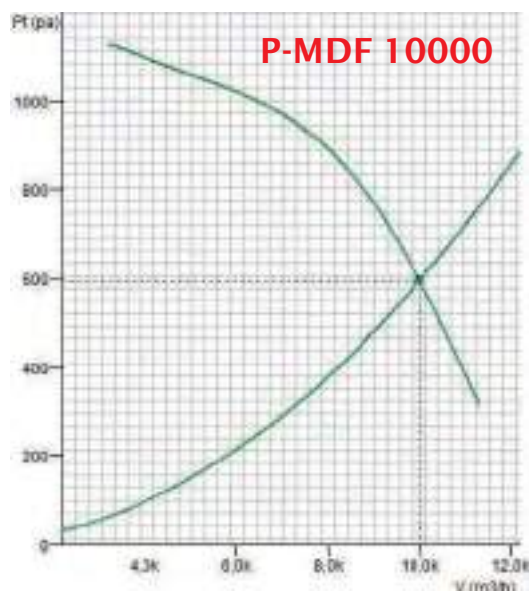
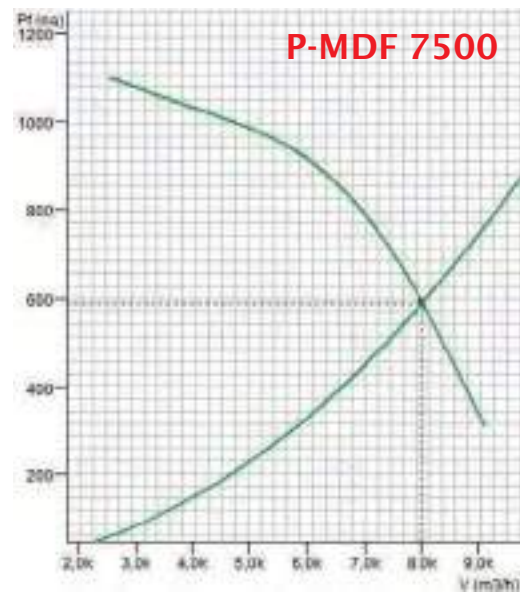
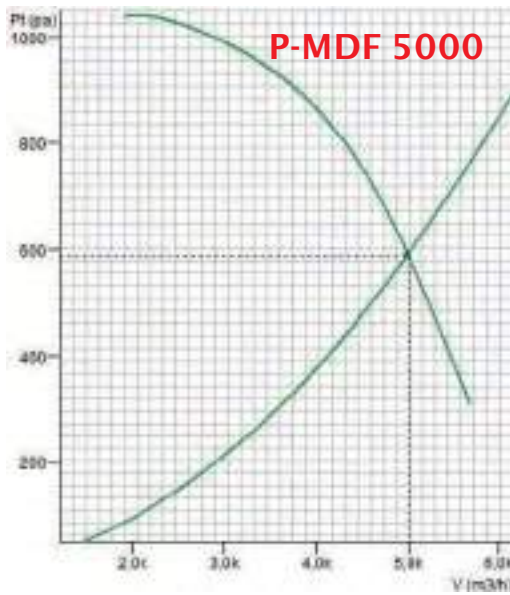
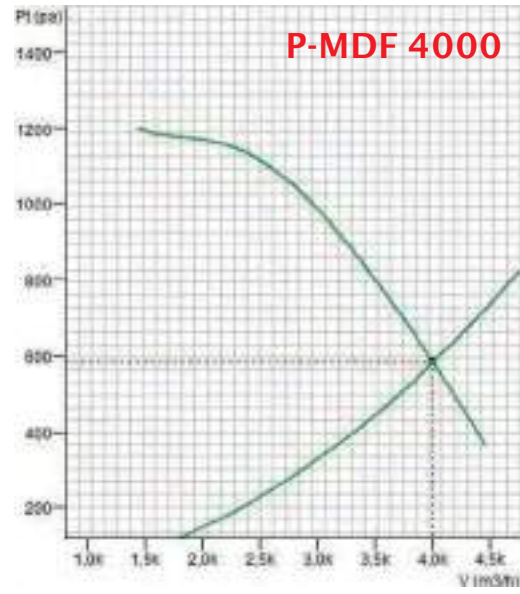
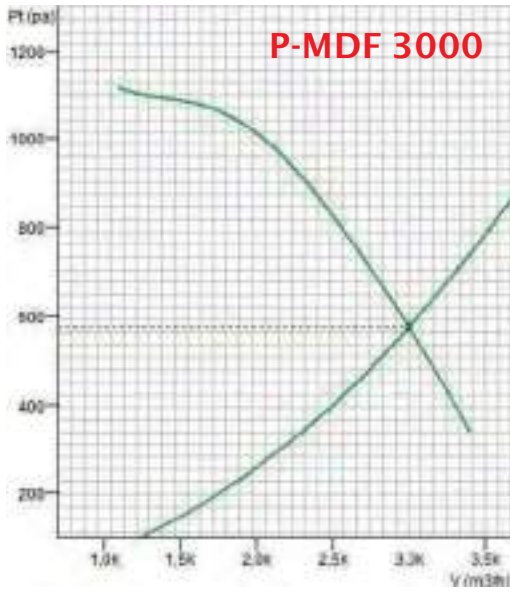

Electrostatic Filter Unit

ESF



Utilization Areas



Description

- * Electrostatic Filter
- * Integrated Automation
- * Oil Retain Filter
- * Noise Heat Insulation
- * Active Carbon Filter
- * Powder coating

Technical Drawing

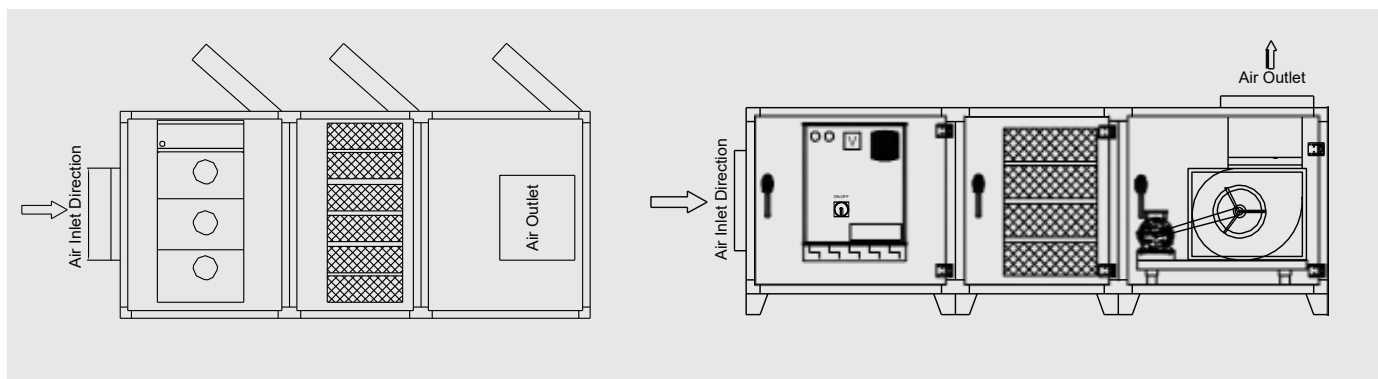

Technical Characteristics

MODELS	FLOW (m³/h)	POWER (kW)	VOLTAGE (V)	SPEED (rpm)	FREQ. (Hz)	NOISE (dbA)
P-ESF 350	3500	1,1	380	1450	50	87
P-ESF 500	5000	1,5	380	1450	50	90
P-ESF 750	7500	3	380	1450	50	94
P-ESF 1000	10000	4	380	1450	50	96
P-ESF 1500	15000	7,5	380	1450	50	98
P-ESF 2000	20000	11	380	1450	50	99



Performance Curves

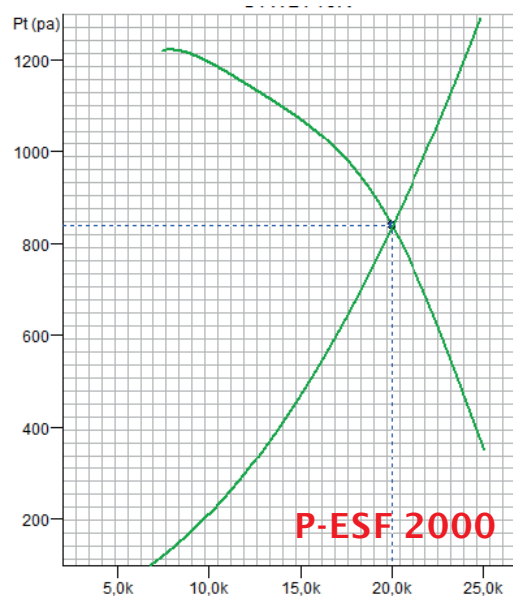
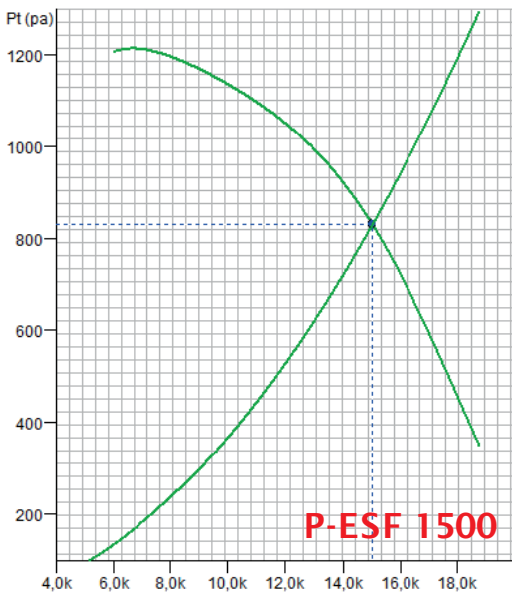
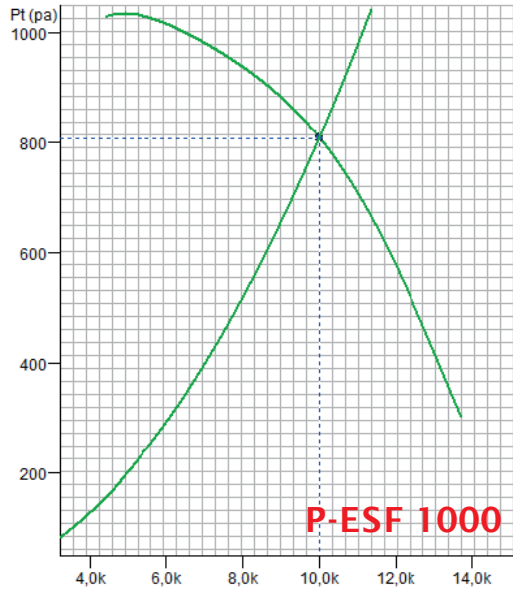
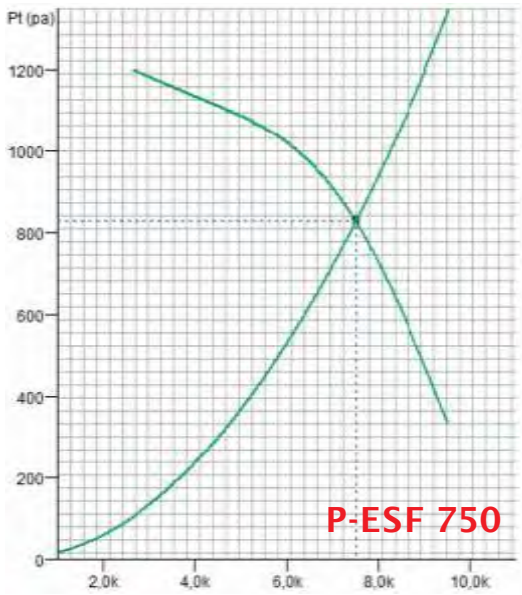
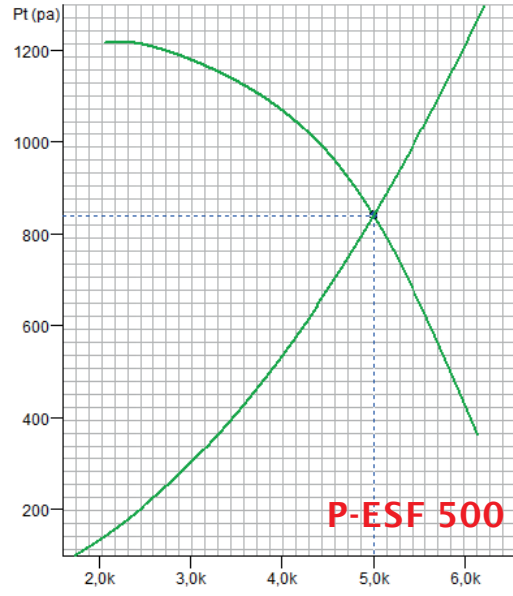
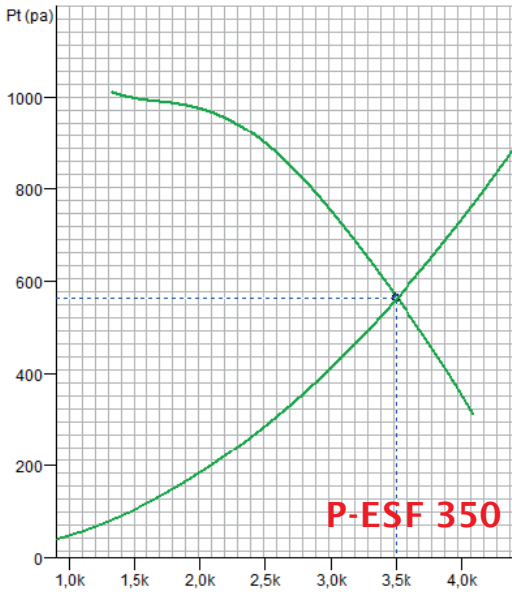

Air Handling Unit

KS



Utilization Areas



Description

- * Aluminum profile Frame
- * Vapor Humidifier
- * Compact Modular Design
- * Integrated Automation
- * Drop Holder
- * Galvanized Sheet Metal
- * Easy Handling, Installation
- * G4- G7 Filter
- * Emergency Start-Stop button
- * Low noise level
- * Technical Support
- * Access Doors

Seçim Tablosu

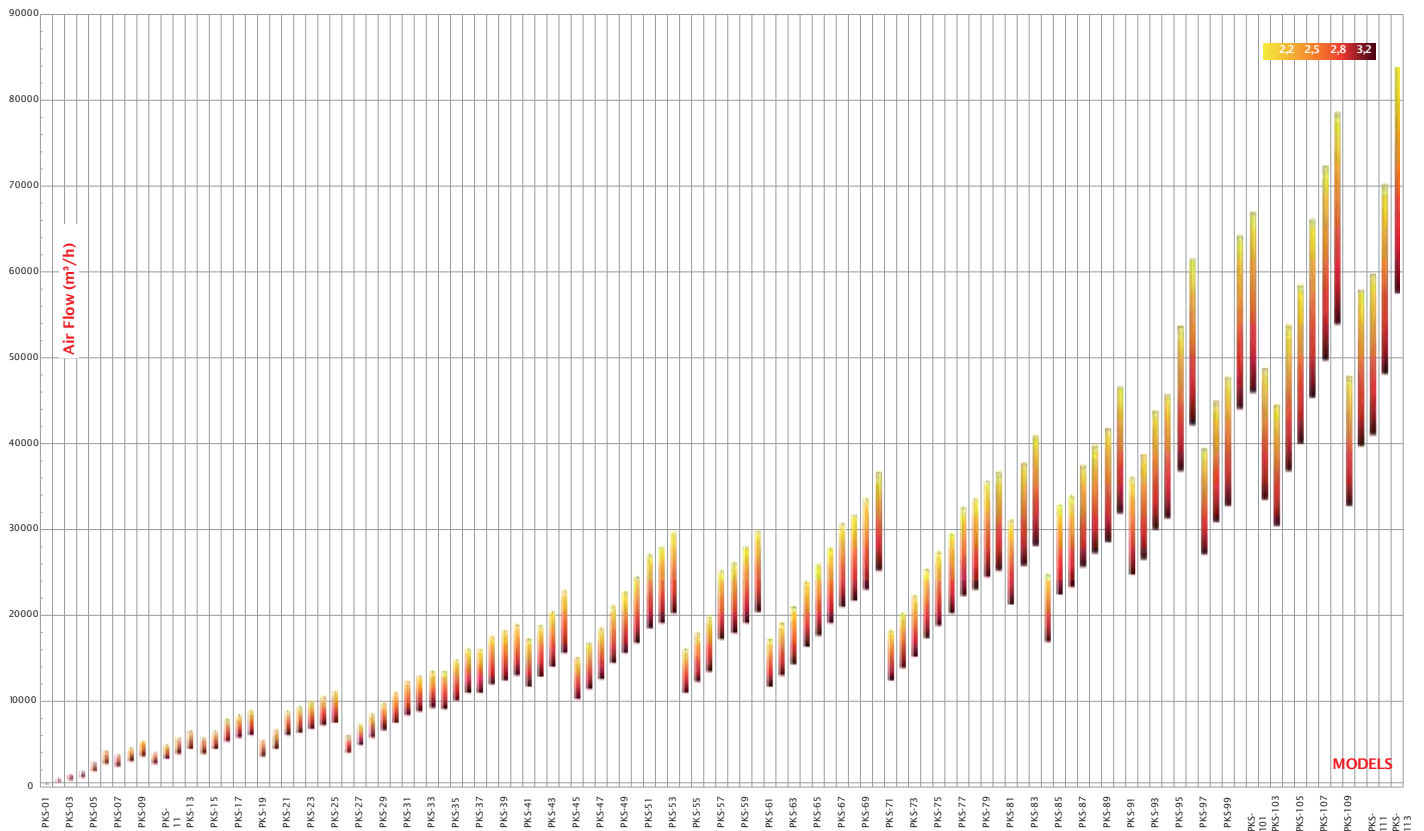

Direction Selection Table

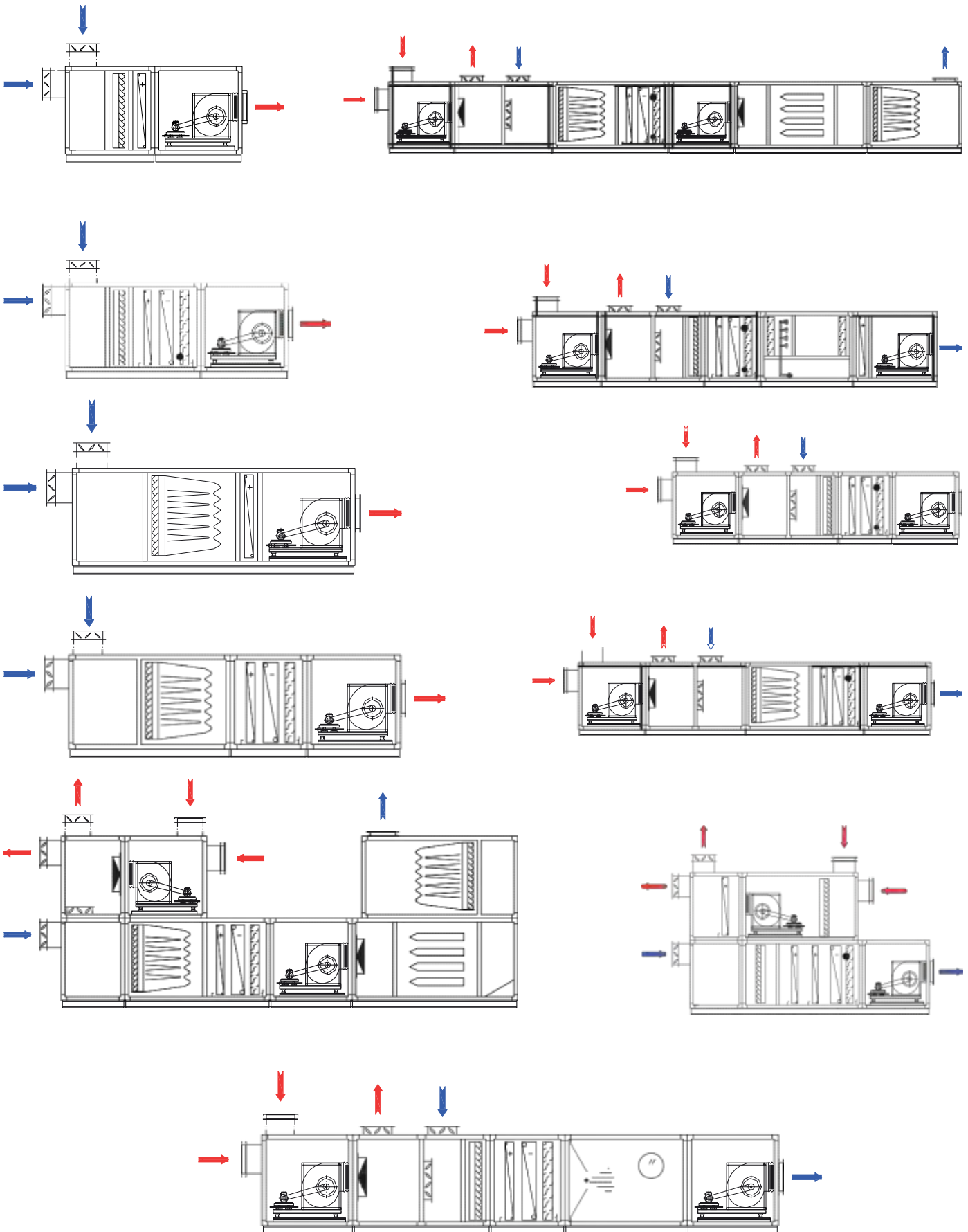

Pool Dehumidification Unit

POOL



Utilization Areas



Technical Drawing

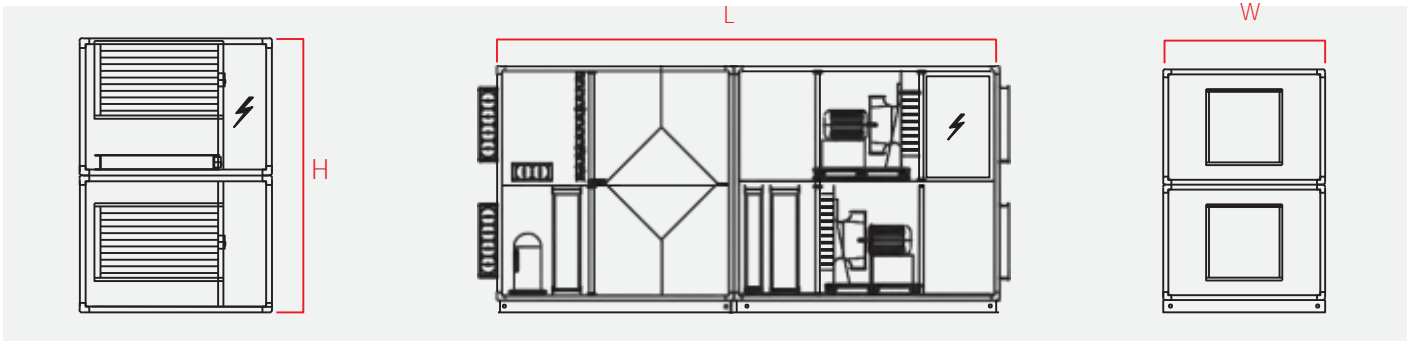

Technical Characteristics

MODEL																																									
TYPE																																									
Dehumidification Capacity*	Kg/h	23,0	21,1	17,9	31,2	27,3	24,9	38,0	37,9	34,9	42,1	39,7	38,9	58,9	57,3	52,4	66,9	64,1	61,4	79,3	78,5	71,2	89,6	84,7	82,1	109,1	106,8	104,9	150,1	142,8	133,6										
Dehumidification Capacity**	Kg/h	24,9				40,2				51,1				62,9				76,8				98,4				112,3				129,4				159,6				201,4			
Air Flow	m ³ /h	4,000				6,000				8,000				10,000				12,000				15,000				18,000				21,000				25,000				31,500			
Cooling Capacity***	kW	24,1	22,3	27,2	39,8	35,4	40,4	50,0	48,2	52,1	57,8	55,6	60,5	75,9	74,7	81,2	87,4	86,3	91,1	94,5	93,2	98,9	116,2	113,5	129,1	143,2	140,8	154,3	187,7	184,3	204,4										
Water Coil Heat. Capacity***	kW	46,8				70,9				106,1				113,4				139,6				155,8				217,2				220,1				279,5				313,6			
Compressor Type		SCROLL			SCROLL			SCROLL			SCROLL			SCROLL			SCROLL			SCROLL			SCROLL			SCROLL			SCROLL			SCROLL									
Number of Compressors	pcs	1			1			1			1			1			2			2			2			2			2			2									
Supply Line Ext. Press. Loss	Pa	300	300	300	300	300	300	300	300	300	300	300	300	300	300	300	300	300	300	300	300	300	300	300	300	300	300	300	300	300	300										
Intake Line Ext. Press. Loss	Pa	300	300	300	300	300	300	300	300	300	300	300	300	300	300	300	300	300	300	300	300	300	300	300	300	300	300	300	300	300	300										
Ventilator Motor Power	kW	2,2	2,2	2,2	4	4	4	5,5	5,5	5,5	7,5	7,5	7,5	7,5	7,5	7,5	11	11	11	11	11	11	15	15	15	15	15	15	15	18,5	18,5	18,5									
Aspirator Motor Power	kW	1,5	1,5	1,5	3	3	3	4	4	4	5,5	5,5	5,5	5,5	5,5	5,5	7,5	7,5	7,5	7,5	7,5	7,5	11	11	11	11	11	11	15	15	15										
Compressor Power Cons.	kW	6,33	6,33	6,33	10,48	10,48	10,48	14,8	14,8	14,8	15,16	15,16	15,16	15,16	15,16	15,16	18,46	18,46	18,46	2,04	2,04	2,04	30,32	30,32	30,32	30,32	31,20	31,2	36,92	36,92	36,92	45,28	45,28	45,28							
Total Power Consumption	kW	10,03	10,03	10,03	17,48	17,48	17,48	24,3	24,3	24,3	28,16	28,16	28,16	34,46	34,46	34,46	40,54	40,54	40,54	48,82	48,82	48,82	57,2	57,2	57,2	62,9	62,9	62,9	78,78	78,78	78,78										

BOYUTLAR																																									
L (LENGTH)	mm	3.700	3.400	3.200	3.900	3.400	3.200	4.000	3.700	3.500	4.500	4.100	4.000	4.700	4.200	4.100	4.900	4.200	4.100	4.900	4.400	4.200	5.500	4.600	4.600	6.100	5.000	5.000	6.600	5.300	5.300										
W (Width)	mm	1050				1250				1350				1450				1800				1900				2300				2500				2700							
H (Height)	mm	1700				2000				2100				2200				2400				2700				2700				3000				3100				3100			
Weight	Kg	600	550	500	1300	1250	1000	1400	1400	1070	1750	1700	1450	950	900	1700	2480	2840	1880	2400	2450	2655	2900	2900	2340	3650	3710	2750	4620	4810	3670										

* In accordance with I O Indoor condition 0 C .T. and 55 H Outdoor condition -1 C .T. and 0rh, 0- 0 C water regime
 P - Plate ecupetator HP - Heat Pipe ecupetator - on Heat ecovey

In-duct Electric Heater

EI



point®



Utilization Areas



Technical Drawing

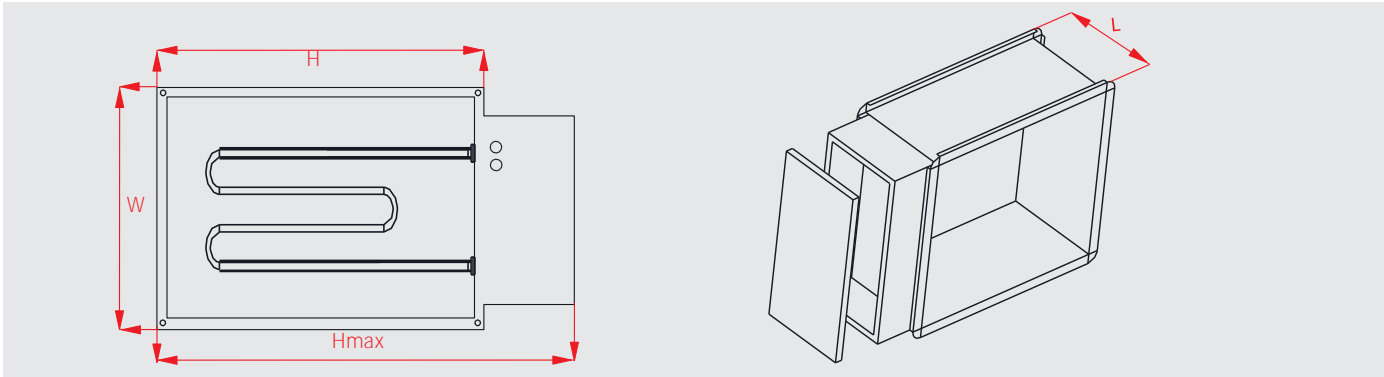

Technical Characteristics

MODELS	POWER (kW)	VOLTAGE (V)	FREQ. (Hz)	KANAL AĞIZ ÖLÇÜSÜ H (mm)	KANAL AĞIZ ÖLÇÜSÜ W (mm)	GENİŞLİK L (mm)	HEIGHT Hmax (mm)
P-EI 3000	3	220	50	300	300	300	450
P-EI 6000	6	380	50	400	300	300	450
P-EI 9000	9	380	50	450	400	400	550
P-EI 12000	12	380	50	600	400	400	550
P-EI 15000	15	380	50	600	500	400	650
P-EI 18000	18	380	50	750	500	400	650
P-EI 21000	21	380	50	850	500	400	650
P-EI 24000	24	380	50	1000	500	400	650

*The delivery and price information for different dimensions should be requested from our factory.

Frequency Invertor

FI



Technical Characteristics

MODELS	GİRİŞ VOLTAGE (V)	ÇIKIŞ VOLTAGE (V)	POWER (kW)
P-FI 10	380	380	0,75
P-FI 15	380	380	1,5
P-FI 22	380	380	2,2
P-FI 30	380	380	3
P-FI 40	380	380	4
P-FI 55	380	380	5,5
P-FI 75	380	380	7,5
P-FI 110	380	380	11
P-FI 150	380	380	15
P-FI 185	380	380	18,5
P-FI 220	380	380	22
P-FI 300	380	380	30
P-FI 370	380	380	37

Speed Controller

HKC



Technical Characteristics

MODELS	VOLTAGE (V)	AMPER (A)
P-HKC 1	220	2
P-HKC 2	220	5
P-HKC 3	220	8

Industrial Ventilator

MFS



Technical Characteristics

MODELS	VOLTAGE (V)	POWER (W)	FREQ. (Hz)	DÖNÜŞ SPEEDİ (rpm)	HAVA HACMİ (m³/h)
P-MFS-500	220	100	50	1350	7000
P-MFS-650	220	130	50	1350	10500
P-MFS-750	220	150	50	1350	16200
P-MFW-500	220	100	50	1350	7000
P-MFW-650	220	130	50	1350	10500
P-MFW-750	220	150	50	1350	16200
P-MFS-S500	220	110	50	1350	8000
P-MFS-S650	220	200	50	1350	12000
P-MFS-S750	220	220	50	1350	18000
P-MFW-S500	220	110	50	1350	8000
P-MFW-S650	220	200	50	1350	12000
P-MFW-S750	220	220	50	1350	18000



Certification

Our Quality Certificates



You can visit our website to view, download and print all of the certificates we have in accordance with 'QUALITY', which forms the basis of our company policy.



her bir adım önde...

MÜŞTERİ İLETİŞİM HATTI
0312 394 57 69

 pointhvac

 pointhvac

 pointhvac

 **HYT GRUP**
HAVALANDIRMA-YALITIM-TESSİSAT

Point Havalandırma Sistemleri
bir HYT Kuruluşudur.

H.Y.T. Grup Lojistik Taş.Mak.Tes.İml.Taah.İth.İhr.San. ve Tic.Ltd.Şti
Saray Mahallesi 195.Cadde No:3/A Kahramankazan/ANKARA
TEL:+90 312 394 57 69 FAX:+90 312 394 32 79
info@hytgrup.com www.hytgrup.com