

Waggoner®

attachments

THINK BIG!

HOLD THE WORLD

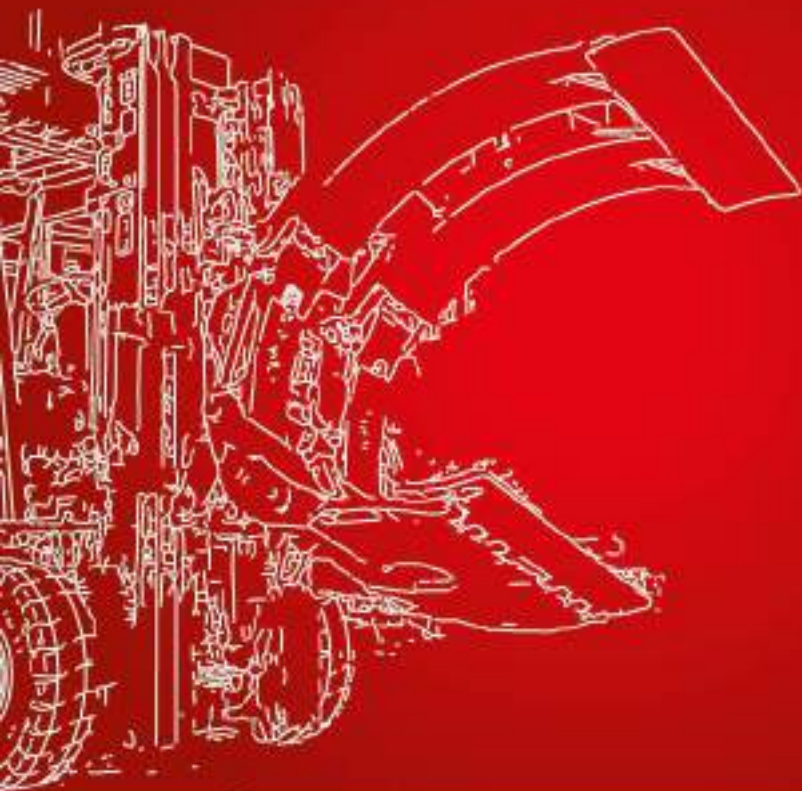

• material
handling
equipments •

ATTACHMENTS

paper roll clamps • rotators • rotating clamps and pallet inverters
side shifter and fork positioners • bale clamps • white good clamps
multi pallet handlers • push and pull units • brick/block and keystone clamps
buckets • mechanical attachments • special attachments



ABOUT US

GÜLMAK İSTİF MAKİNALARI SAN. VE TİC. LTD. ŞTİ.'s origin was established in 1968 by Selim Gül to provide maintenance and repair activities for forklifts, telehandlers, construction equipments and their attachments. In 2004, it continues its strong presence in the sector with the production of high quality forklift and telehandler attachments in the local and global markets of the sector under the brand of "Wagger Attachments".

Today, Wagger Is The Leading Manufacturer of Forklift Truck Attachments, Telehandler Attachments, Backhoe Loader Attachments And SSL Attachments, with The Most Extensive Product Range In Turkey.

WAGGER has been active for almost twenty years in the design, manufacture and distribution of forklift attachments and industrial material handling equipments.

WAGGER started by establishing a system that consistently produces attachments with high quality and aesthetic production methods, focused on customer satisfaction, which are accepted all over the world.

To achieve this, WAGGER created a model that will enable growth with both users and suppliers. WAGGER has always supported this philosophy with the slogan of "True success is repeatable success". WAGGER distributors, WAGGER suppliers and WAGGER employees were identified as the three most important elements that underpin this philosophy.

Above all, WAGGER defended its commitment to the systems approach. Thus, while many of its most famous attachments, such as bale clamps, rotators, paper roll clamps and multi pallet handlers, were carefully created, the WAGGER production system required adherence to the principles of quality, aesthetics and customer satisfaction in all of its products.

WAGGER's passion for quality meant testing components to fit the production system, perfecting products, WAGGER shared its vision for the future with suppliers and ensured their commitment to the system's quality concept. Thus, it has always succeeded in producing quality, aesthetic and customer oriented production at the same standard.

From its passion for quality and efficiency to its relentless pursuit of aesthetics, WAGGER's inspiring initiatives remain an integral part of WAGGER culture today and into the future.





CONTACT

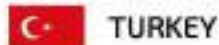

TURKEY

GULMAK ISTIF MAKINALARI SAN. VE TIC. LTD. ŞTI.
YESILOBA MAH. ORTA OLCEKLI SANAYI SITESI 46247 SOKAK NO:17
SEYHAN / ADANA / TURKEY

Phone: +90 (322) 428 08 58 - 428 08 97 Fax: +90 (322) 428 09 25
Web: www.wagger.com.tr E-mail: info@wagger.com.tr



THINK BIG!
HOLD THE WORLD

PAPER ROLL CLAMPS

1

ROTATORS

2

**ROTATING CLAMPS &
PALLET INVERTER**

3

**SIDE SHIFTER &
FORK POSITIONERS**

4

BALE CLAMPS

5

WHITE GOOD CLAMPS

6

MULTI PALLET HANDLERS

7

PUSH & PUSH PULLS

8

**BRICK/BLOCK &
KEYSTONE CLAMPS**

9

BUCKETS

10

MECHANICAL ATTACHMENTS

11

SPECIAL ATTACHMENTS

12



DATA SHEET

GENERAL TERMS AND CONDITIONS

1. Ordering Information

Following information is required to process your order as fast as possible:

- Product code of the required unit from the technical table.
- Lift track model and mounting class of fork carriage.

Orders for spare parts must be accompanied by the serial number of the Wagger attachment written on the name plate.

2. Dimensions, Weight and Technical Data

Dimensions, weight and pictures are non-binding and all are subject to change with the required unit specification. Technical drawings are mainly standart and can not display all available types, they only show the build principle. The right of technical changes and further developments without notice are reserved.

3. Special Products

Special or customized products are available on request. A complete description of the application is required to specify the technical requirements.

4. Painting

Wagger Attachments are painted with Wagger special red . Further colour is available on request.

5. Certificate

Wagger is certified according to DIN EN ISO 9001:2008 Quality Management System and DIN EN ISO 3834-2 Welding Quality Assurance.

6. Delivery

Delivery is EXW Adana Wagger Factory unless otherwise agreed upon.

7. Guarantee

For a period of 12 months, or 2.000 work hours (whichever comes first), from the date of delivery to customer, Wagger Attachments, at its option, will repair or replace for the original purchaser, free of charge, any part or parts of the attachment found, upon examination by Wagger Attachments, to be defective in material or workmanship, or both.

This warranty does not apply if such defect has been caused by alteration, improper use, failure to provide proper maintenance, or operation contrary to Wagger Attachment's installation and service instructions.

1. Attachment Capacity

The rated capacity of each Wagger attachment is a structural rating only. The type of product to be handled as well as the operating conditions must be considered before the working capacity for each application can be properly determined; hard, slippery loads, for example, require more clamping force, using the same clamp, than soft compressible ones. Fast driving across uneven surfaces produces far higher dynamic loadings than traveling slowly over smooth warehouse floors. Certain lift truck specifications, such as lift height, also influence the residual capacity and must also be considered.

The attachment capacities shown are nominal and they apply only to the individual attachment and not to the capacity of lift truck. Attachment capacity, combined with truck rating, determines the net working capacity of the combination. This net attachment/truck capacity must be determined by the lift truck manufacturer. An approximate estimate of the net capacity is available by following the step-by-step calculation on net capacity page of this catalogue.

Attachment capacities are given at 500mm load centres unless otherwise stated. For load centres greater than 500mm a lower capacity applies. Consult the attachment specification sheets or contact Wagger for capacity derations.

2. Mounting Class

Mounting Class refers to the type of mounting hooks that are on the rear face of the attachment and are used to mount the attachment to the lift truck. Mounting Class 2 refers to Standard ISO Class 2 hooks, Mounting Class 3 to Standard ISO Class 3 hooks etc. These standard hooks are supplied with the attachment, but the lift truck requires standard ISO hook type carriage bars to utilize these standard hooks. The rear face of each attachment has been designed so that other types of mounting adaptations can be used to mount on lift trucks that do not have ISO hook type carriage bars. For all mountings other than the standard ISO-2328 type, contact Wagger.

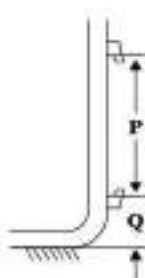

Mounting Class	Lift truck capacity at loadcentre kg/mm	P mm	Q mm
1A	Up to 999 kg at 500 mm	331	76
1B		331	114
2A	1000-2500kg at 500 mm	407	76
2B		407	152
3A	2501-4999kg at 500 mm	508	76
3B		508	203
4A	5000-8000kg at 600 mm	635	127
4B		635	254
5A	8001-10999kg at 600 mm	798	127
5B		798	257

Class A- Versions of these mountings are offered as standard.

Specifications for Wagger Attachments are based on 2A/3A/4A mounting. Specifications for 2B/3B/4B mountings may vary, please contact Wagger. Always specify the mounting you require. Note that for some clamps, especially those with extended opening ranges, the spacing of the mounting hooks may require a wider lift truck mast carriage.

3. Toe-in

The distance between the arms or forks (e.g. Bale Clamps, Brick Clamps, Fork Clamps) differs, measured on the tips of the arms compared to the rear side of the arms. This is referred to as clamp toe-in. The opening ranges given in our brochure are always measured at the rear of the arms. With an arm length of 1.000 mm the toe-in is approximately 30 mm (15 mm to each side). This is necessary to compensate the natural deflection of the clamping arms during transport. Without toe-in load would be clamped at the rear side but would fall through at the tips. For handling sensitive goods such as television sets, Appliance clamps and Carton Clamps with adjustable toe-in are available.

4. Installation

All hydraulic components required to mount the attachment on a lift truck and connect it to the truck's hydraulic circuit (auxiliary valve) are available from Wagger. Hydraulic Supply Group are listed in page ... of this catalogue.

4.1. Hydraulic Functions

A hydraulic operated lift truck attachment requires at least one hydraulic function from the lift truck hydraulic system. Fork positioners and clamps require normally two hydraulic functions.

Special attachments, and attachment combinations, may require three, four, or even more hydraulic functions. See the product data tables for further information.

4.2. Hydraulic Connections

SAE	Metric Pipe O.D.	BSP Female 60° Cone
No. 6	10 mm	6 mm
No. 8	12 mm	9 mm
-	15 mm	12 mm

Wagger attachments can be supplied with various hydraulic connectors. The following connections are available. Please specify on ordering.

4.3. Operating Pressures

All standart attachments are suitable for lift truck operating pressures up to 160 bar, unless otherwise indicated. Sideshift Carriages are suitable up to 210 bar, Hose reels 210 bar, Thinline hose reels 240 bar, these pressures are however limited by the maximum hose pressures.

4.4. Hydraulic Flow Rate

The quantity of oil supplied to an attachment per minute is of great importance for its satisfactory operation. Normally, a lift truck can supply sufficient flow to operate an attachment. Should this not be the case, contact Wagger. If the flow is too great, the oil temperature can increase, effecting service life of hydraulic components. Installation of a hydraulic flow control valve in the supply circuit is then recommended.

DATA SHEET

NET CAPACITY

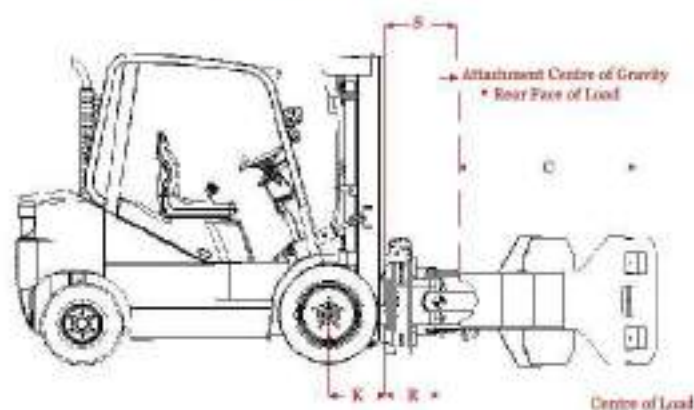
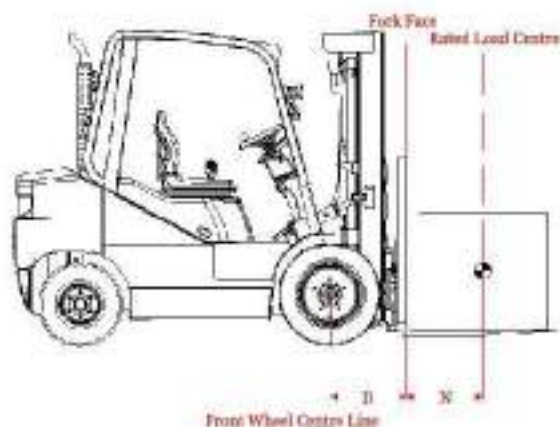

A : Truck's basic capacity

D : Distance from front wheel centre line to fork face

N : Distance from fork face to rated load centre

Z : Weight of attachment

K : Distance from front wheel centre line to carriage face

R : Distance from carriage face to attachment's centre of gravity (ACG)

S : Distance from carriage face to rear face of the load (ET)

C : Distance from rear face of load to centre of load

$$\text{Net capacity} = \frac{A(D+N) - Z(K+R)}{K+S+C}$$

Important remark : Formulas can give you a good estimate of how capacity will be affected. But in fact the residual capacity of the lift truck / attachment combination must be determined according to the instruction of the Lift Truck Manufacturer (EEC Directive 98 / 37)

DATA SHEET

LIFT TRUCK CARRIAGE STANDARDS

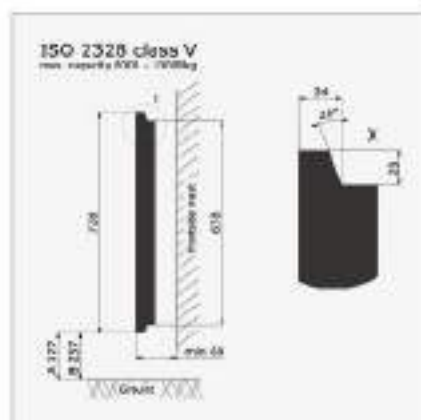
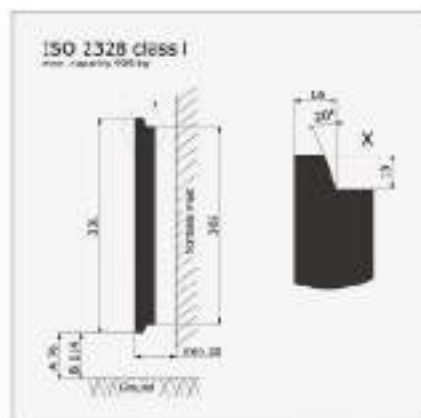

Wagner®
attachments

INDEX

PAPER ROLL CLAMPS

PRA	360° Rotating Paper Roll Clamps	1-1 . 1-3
PRC	360° Rotating Paper Roll Clamps - Split Arms	1-4 . 1-5
PRT	360° Rotating Tissue Paper Roll Clamps	1-6 . 1-7
PRR	Non-Rotating Paper Roll Clamps	1-8

ROTATORS

RBG	360° Rotators	2-1
RBC	180° Rotators	2-2
RBU-12	120° Rotators	2-3
RBU	90° Rotators	2-4
RBX-A	360° Rotators With Hydraulic Bin Retainer	2-5
RBX-F	180° Rotators With Hydraulic Bin Retainer	2-6
RBX-R	180° Rotators With Hydraulic Bin Retainer	2-7
RBX-C	180° Rotators With Prehensile Arm	2-8

ROTATING CLAMPS & PALLET INVERTER

CPT	360° Rotating Fork Clamps	3-1
CPR	360° Rotating Pallet Inverter Clamps	3-2

SIDE SHIFTERS & FORK POSITIONERS

YKX	Hook-On Side Shifters - S Profil / 2 - 4 Ton	4-1
YKZ	Hook-On Side Shifters - Heavy Duty / 4,5 - 8 Ton	4-2
FRN	Fork Positioners With Side Shifter	4-3
FPN	Heavy Duty Fork Positioners With Side Shifter	4-4
FPN-C	Heavy Duty Fork Positioners With Side Shifter And Forks	4-5
FAR	360° Rotating Fork Positioners	4-6

BALE CLAMPS

CAP	Cotton Bale Clamps	5-1 . 5-6
CBA	Recycling Bale Clamps	5-7
CSA	Cellulose Clamps	5-8
CSR	Tobacco Clamps	5-9
CSR-L	Tobacco Clamps - Long Arm	5-10
CFB	Foam Rubber Clamps	5-11
CTC	Pole Tine Clamps	5-12
CAN	Fork Clamps	5-13
CFP	Fork Clamps With Manually Turnable Forks	5-14

INDEX

WHITE GOODS CLAMPS

WGC	White Goods Clamps	6-1, 6-3
-----	--------------------	----------

MULTI PALLET HANDLERS

MPH	Multi Pallet Handlers	7-1
-----	-----------------------	-----

PUSH AND PUSH-PULL ATTACHMENTS

SCU	Load Push Attachments	8-1
SCK	Load Push-Pull Attachments	8-2
SPK	360° Rotating Load Push Attachments	8-3

BRICK - BLOCK AND KEYSTONE CLAMPS

BFP	Brick- Block Clamps With Forks	9-1
BSP	Brick- Block Clamps With Forks / Large Pads	9-2
BAP	Brick - Block Clamps With Pistons	9-3
DGA	Two Sided Keystone Clamps	9-4
SGA	Four Sided Keystone Clamps	9-5

BUCKETS

LMB	Hydraulic Buckets	10-1
LMF	Hydraulic Buckets On Forks	10-2
	Density Table of Some Product	10-3

MECHANICAL ATTACHMENTS

AX	Crane Hooks	11-1
AH	Jim Boom On Forks	11-2
AT	Jim Boom	11-3
DMS	Metal Drum Attachments	11-4
DPS	Plastic Drum Attachments	11-5
DRS	Plastic Drum Attachments	11-6
WPI	Working Platform	11-7
BK	Dumping Bucket	11-8
KK	Snow Plough	11-9
CK	Fork Extension	11-10, 11-12
CZ	Load Balancing Forks	11-13
CZ-R	Load Balancing Forks, Hook-On Type	11-14
CC	Carpet Carrying Rams	11-15, 11-22
FT	Heavy Material Carrying Rams	11-23

SPECIALTY PRODUCTS

FMA	Forging Manipulator	12-1
CPC	Concrete Pipe Clamp	12-1
PTC	Tyre Clamp	12-2
PLY	Picker Layer	12-2
DPC	Casting Ladle Attachment	12-3
CDR	Box Dumpers With 360 Rotating	12-3
DAT	Drums Pickle	12-4
SPU	Load Extender	12-4
LSB	Load Stabilizer	12-5
SPR-C33X	Forklift Sweeper - Hydraulic	12-5
CAX	Cotton Bale Clamp - Tubular Chassis	12-6
TGT	Logging Tong Clamp Without Forks	12-6
FXF	Fork Positioner	12-7
FKF	Fork Positioner	12-7
YKT	Integral Side Shifter	12-8
YKY	Integral Side Shifter	12-8
FMB	Forklift Mast	12-9
RBR	180° Rotator Board	12-9
RGA	360° Rotating Keystone Clamp	12-10
DAZ	180° Rotating Drum Clamp	12-10
DAV	360° Rotating Drum Clamp	12-11
DAX	360° Rotating Drum Clamp	12-11
HT	Hydraulic Jim Boom	12-12
CR	Forks Extension For Circle Loads	12-12
QC	Quick Coupling	12-13
BB	Big Bag Attachments	12-13
YD	Load Backrest	12-14
FB	Forklift Board	12-14
SCE	Load Extender	12-15
HBA	Hinged Bucket Attachment	12-15
CPT	360° Rotating Pallet Inverter	12-16
RBD	180° Box Rotator	12-16
CPC	360° Rotating Pallet Inverter	12-17
CPT	360° Rotating Pallet Inverter with Side Panel	12-17
HFA	Hinged Fork Attachment	12-18
RTC	360° Rotating Tyre Clamp	12-18
PHC	Pipe Handler with Fork Positioner	12-19

Wagger[®]

attachments

THINK BIG!
HOLD THE WORLD

Paper Roll Clamps

PRA	360° Rotating Paper Roll Clamps	I-1, 13
PRC	360° Rotating Paper Roll Clamps - Split Arms	I-4, 15
PRT	360° Rotating Tissue Paper Roll Clamps	I-6, 17
PRR	Non-Rotating Paper Roll Clamps	I-8

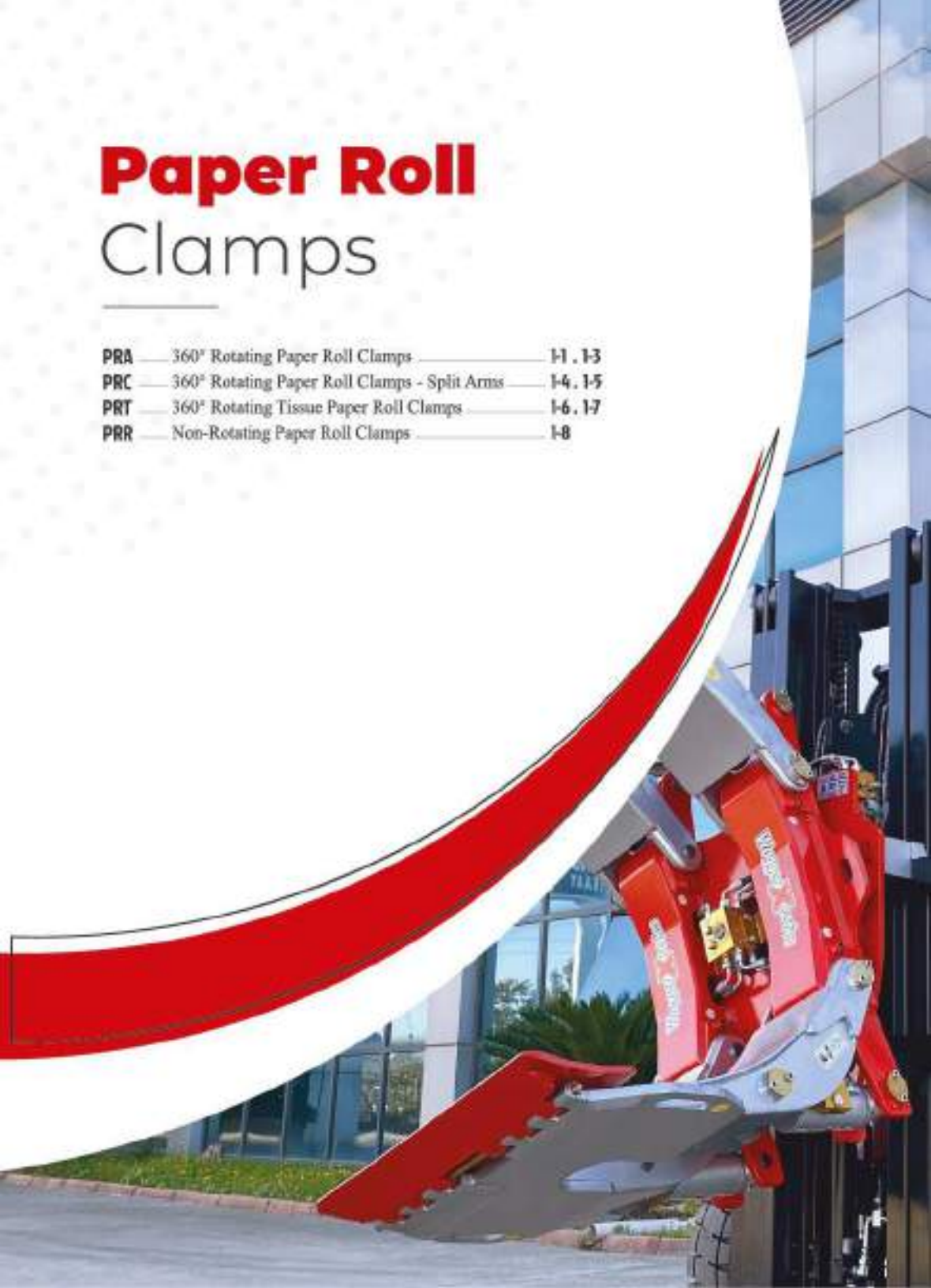



Waggener **X**series



Paper Roll
Clamps

PRA PAPER ROLL CLAMPS

360° Rotating Paper Roll Clamps

Wagner®
attachmore®

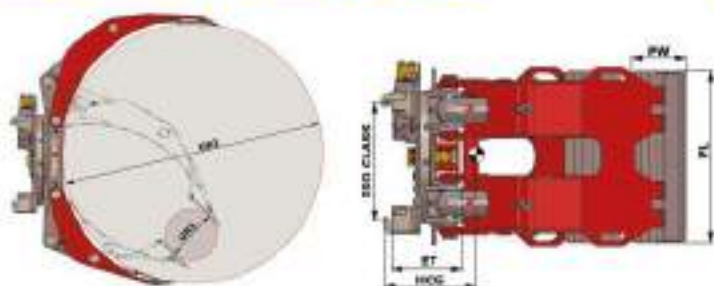

Catalogue Order No	Part No	Capacity (kg/mm)	Roll Range (mm)	Short Arm	Mounting Class	Pad Size (mm)	Effective Thickness (mm)	Horizontal Centre of Gravity (mm)	Weight (kg)	Price
			ORL-ORL	F+	ISO2528	PW-PL	ET	HCC	W	€
012PRA-A0250*	PRA122512	1200/900	250-1200	fixed	2A	240-690	262	350	455	
012PRA-A0450*	PRA123014	1100/700	300-1400	fixed	2A	240-660	262	390	415	
012PRA-A0652*	PRA123514	1000/900	350-1600	fixed	2A	240-640	262	425	548	
016PRA-B023U	PRA162512	1600/900	250-1200	variable	2A/3A	240-700	286	352	690	
016PRA-B025I	PRA164612	1600/900	460-1200	fixed	2A/3A	240-700	286	352	630	
016PRA-B048G	PRA162514	1520/700	250-1400	variable	2A/3A	240-700	286	360	690	
016PRA-B048G	PRA164614	1520/700	460-1400	fixed	2A/3A	240-700	286	360	670	
016PRA-B068Z	PRA142516	1450/900	250-1600	variable	2A/3A	240-700	286	394	760	
016PRA-B068Z	PRA144616	1450/900	460-1600	fixed	2A/3A	240-700	286	394	742	
020PRA-B048G	PRA202514	2000/700	250-1400	variable	3A	240-700	288	370	744	
020PRA-B048G	PRA204614	2000/700	460-1400	fixed	3A	240-700	288	370	728	
020PRA-B068Z	PRA182516	1880/900	250-1600	variable	3A	240-700	288	421	851	
020PRA-B068Z	PRA184616	1880/900	460-1600	fixed	3A	240-700	288	421	833	
026PRA-B048G	PRA262514	2600/700	250-1400	variable	3A	240-700	291	373	763	
026PRA-B048G	PRA264614	2600/700	460-1400	fixed	3A	240-700	291	373	748	
026PRA-B068Z	PRA242516	2450/900	250-1600	variable	3A	240-700	291	426	846	
026PRA-B068Z	PRA244616	2450/900	460-1600	fixed	3A	240-700	291	426	831	
026PRA-B083Y	PRA212518	2300/900	250-1800	variable	3A	240-700	291	448	938	
026PRA-B083Y	PRA214618	2300/900	460-1800	fixed	3A	240-700	291	448	878	

- 360° rotating paper roll clamp for vertical and horizontal handling of single rolls.
- Short arm that can be adjusted only 45°.
- 012PRA model is fixed short arm. Other models is hydraulically positionable short arm with wider roll diameter range.
- 2 hydraulic function.
- Standard contact pads ; Cast pad with high-friction surface.
- Contact pad options : Polyurethane, rubber faced.
- Side shift feature is not available.
- The quick release feature is optional.
- (*) Marked models are visually different.



PRA PAPER ROLL CLAMPS

360° Rotating Paper Roll Clamps

Wagger®
attachments

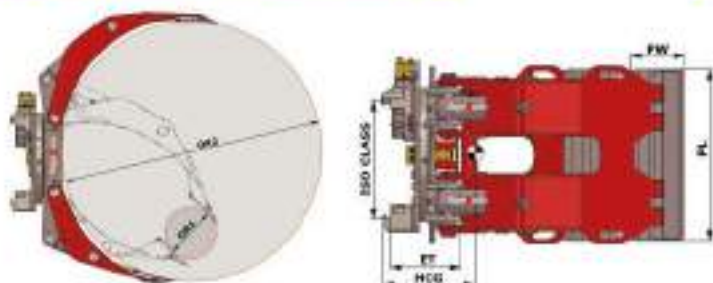

Catalogue Order No	Part No	Capacity (kg/mm)	Roll Range (mm)	Short Arm	Mounting Class	Pad Size (mm)	Effective Thickness (mm)	Horizontal Centre of Gravity (mm)	Weight (kg)	Price
			001-092	0°	ISO128	PW-PL	ET	HCCG	W	€
030PRA-B04HG	PRA302514	3000/700	250-1400	variable	3A	240-800	295	393	980	
030PRA-B04SG	PRA304614	3000/700	460-1400	fixed	3A	240-800	295	393	935	
030PRA-B06H2	PRA292516	2910/800	250-1600	variable	3A	240-800	295	412	1065	
030PRA-B06S2	PRA294616	2910/800	460-1600	fixed	3A	240-800	295	412	1000	
030PRA-B08H1Y	PRA282218	2800/900	250-1800	variable	3A	240-800	295	438	1125	
030PRA-B08S1Y	PRA284618	2800/900	460-1800	fixed	3A	240-800	295	438	1085	
030PRA-B10HP	PRA272520	2700/1000	250-2000	variable	3A	240-800	295	454	1174	
030PRA-B10SP	PRA274620	2700/1000	460-2000	fixed	3A	240-800	295	454	1199	
035PRA-C04HG	PRA352814	3500/700	280-1400	variable	3A/4A	240-900	305	363	1255	
035PRA-C04SG	PRA354314	3500/700	430-1400	fixed	3A/4A	240-900	305	363	1220	
035PRA-C06H2	PRA342816	3400/800	280-1600	variable	3A/4A	240-900	305	395	1325	
035PRA-C06S2	PRA344316	3400/800	430-1600	fixed	3A/4A	240-900	305	395	1285	
035PRA-C08H1Y	PRA322818	3300/900	280-1800	variable	3A/4A	240-900	305	412	1345	
035PRA-C08S1Y	PRA334318	3300/900	430-1800	fixed	3A/4A	240-900	305	412	1335	
035PRA-C10HP	PRA322820	3200/1000	280-2000	variable	3A/4A	240-900	305	431	1460	
035PRA-C10SY	PRA324320	3200/1000	430-2000	fixed	3A/4A	240-900	305	431	1410	

- 360° rotating paper roll clamp for vertical and horizontal handling of single rolls.
- Short arm that can be adjusted only 45°.
- 012PRA model is fixed short arm. Other models is hydraulically positionable short arm with wider roll diameter range.
- 2 hydraulic function.
- Standard contact pads ; Cast pad with high-friction surface. Contact pad options ; Polyurethane, rubber faced.
- Side shift feature is not available.
- The quick release feature is optional.



PRA PAPER ROLL CLAMPS

360° Rotating Paper Roll Clamps

Wagner®
attachmore®

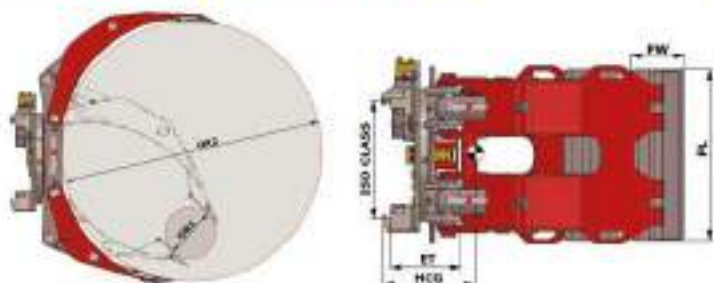

Catalogue Order No	Part No	Capacity (kg/mm)	Roll Range (mm)	Short Arm	Mounting Class	Pad Size (mm)	Effective Thickness (mm)	Horizontal Centre of Gravity (mm)	Weight (kg)	Price
			ORI-OR2	1°	ISO228	PW-PL	ET	HCG	W	€
040PRA-C04EK	PRA402814	4000/700	280-1400	variable	1A/1A	290-900	310	368	1330	
040PRA-C04SG	PRA404814	4000/700	480-1400	fixed	1A/1A	290-900	310	368	1245	
040PRA-C06EIZ	PRA382816	3800/800	280-1600	variable	3A/1A	290-900	310	397	1420	
040PRA-C06SZ	PRA385116	3800/800	510-1600	fixed	3A/1A	290-900	310	397	1375	
040PRA-C08EIZ	PRA362818	3600/900	280-1800	variable	3A/1A	290-900	310	438	1490	
040PRA-C08SY	PRA364318	3600/900	430-1800	fixed	3A/1A	290-900	310	438	1440	
040PRA-C10EIP	PRA345020	3400/1000	500-2000	variable	1A/4A	290-900	310	454	1815	
040PRA-C10SP	PRA347020	3400/1000	700-2000	fixed	1A/4A	290-900	310	454	1525	
050PRA-C06EIZ	PRA502816	5000/800	280-1600	variable	4A	290-1130	326	366	1655	
050PRA-C06SZ	PRA505016	5000/800	500-1600	fixed	4A	290-1130	326	366	1680	
050PRA-C08EIZ	PRA472818	4780/900	280-1800	variable	4A	290-1130	326	398	1720	
050PRA-C08SY	PRA474318	4780/900	430-1800	fixed	4A	290-1130	326	398	1670	
050PRA-C10EIP	PRA455020	4510/1000	500-2000	variable	4A	290-1130	326	412	1815	
050PRA-C10SP	PRA457020	4510/1000	700-2000	fixed	4A	290-1130	326	412	1745	

- 360° rotating paper roll clamp for vertical and horizontal handling of single rolls.
- Short arm that can be adjusted only 45°.
- 012PRA model is fixed short arm. Other models is hydraulically positionable short arm with wider roll diameter range.
- 2 hydraulic function.
- Standard contact pads ; Cast pad with high-friction surface. Contact pad options ; Polyurethane, rubber faced.
- Side shift feature is not available.
- The quick release feature is optional.



PRC PAPER ROLL CLAMPS

360° Rotating Paper Roll Clamps - Split Arms

Wagger®
attachments

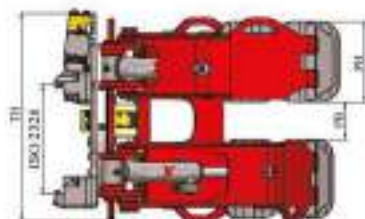
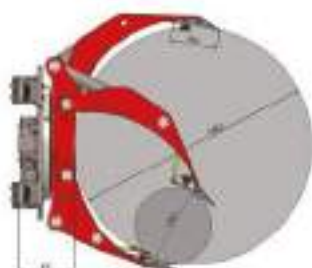

Catalogue Order No	Part No	Capacity (kg/mm)	Roll Range (mm)	Short Arm	Mounting Class	Pad Size (mm)	Effective Thickness (mm)	Horizontal Centre of Gravity (mm)	Weight (kg)	Price
016PRC-B04HG	PRC162514	1600/700	250-1400	variable	2A-3A	248-298	298	325	610	
016PRC-B04SG	PRC165614	1600/700	560-1400	fixed	2A-3A	248-298	298	325	595	
016PRC-B06HZ	PRC142516	1450/800	250-1600	variable	2A-3A	248-298	298	357	680	
016PRC-B06SZ	PRC145616	1450/800	560-1600	fixed	2A-3A	248-298	298	357	664	
020PRC-B04HG	PRC202514	2000/700	250-1400	variable	1A	248-298	311	347	650	
020PRC-B04SG	PRC205614	2000/700	560-1400	fixed	1A	248-298	311	347	626	
020PRC-B06HZ	PRC182516	1800/800	250-1600	variable	1A	248-298	311	376	735	
020PRC-B06SZ	PRC185616	1800/800	560-1600	fixed	1A	248-298	311	376	712	
026PRC-B04HG	PRC262514	2600/700	250-1400	variable	1A-4A	248-408	315	365	814	
026PRC-B04SG	PRC265614	2600/700	560-1400	fixed	1A-4A	248-408	315	365	792	
026PRC-B06HZ	PRC242516	2400/800	250-1600	variable	1A-4A	248-408	315	392	896	
026PRC-B06SZ	PRC245616	2400/800	560-1600	fixed	1A-4A	248-408	315	392	848	
026PRC-B08HY	PRC232518	2300/900	250-1800	variable	1A-4A	248-408	315	430	960	
026PRC-B08SY	PRC235618	2300/900	560-1800	fixed	1A-4A	248-408	315	430	954	

- 360° rotating paper roll clamp for vertical and horizontal handling of single or double rolls.
- Short arm that can be adjusted only 45°.
- 2 hydraulic function.
- Standard contact pads ; Cast pad with high-friction surface.
Contact pad options : Polyurethane, rubber faced.
- Side shift feature is not available.
- The quick release feature is optional.



PRC PAPER ROLL CLAMPS

360° Rotating Paper Roll Clamps - Split Arms

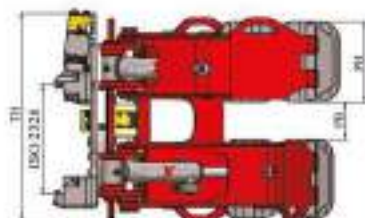
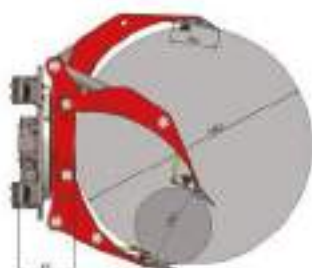

Catalogue Order No	Part No	Capacity (kg/mm)	Roll Range (mm)	Short Arm	Mounting Class	Pad Size (mm)	Effective Thickness (mm)	Horizontal Centre of Gravity (mm)	Weight (kg)	Price
			DR1-DR2	Ev	ISO2328	PW-PL	ET	HCG	W	€
090PRC-B048D	PRC302514	3000/700	250-1400	variable	3A-4A	240-400	323	382	1095	
090PRC-B048G	PRC305614	3000/700	560-1400	fixed	3A-4A	240-400	323	382	1058	
090PRC-B068Z	PRC282516	2900/800	250-1600	variable	3A-4A	240-400	323	408	1180	
090PRC-B068Z	PRC285616	2900/800	560-1600	fixed	3A-4A	240-400	323	408	1148	
090PRC-B088Y	PRC282518	2800/900	250-1800	variable	3A-4A	240-400	323	452	1237	
090PRC-B088Y	PRC285618	2800/900	560-1800	fixed	3A-4A	240-400	323	452	1205	
090PRC-B108Y	PRC272520	2700/1000	250-2000	variable	3A-4A	240-400	323	478	1310	
090PRC-B108Y	PRC275620	2700/1000	560-2000	fixed	3A-4A	240-400	323	478	1275	

- 360° rotating paper roll clamp for vertical and horizontal handling of single or double rolls.
- Short arm that can be adjusted only 45°.
- 2 hydraulic function.
- Standard contact pads; Cast pad with high-friction surface. Contact pad options: Polyurethane, rubber faced.
- Side shift feature is not available.
- The quick release feature is optional.



PRT PAPER ROLL CLAMPS

360° Rotating Tissue Paper Roll Clamps

Wagger®
attachments

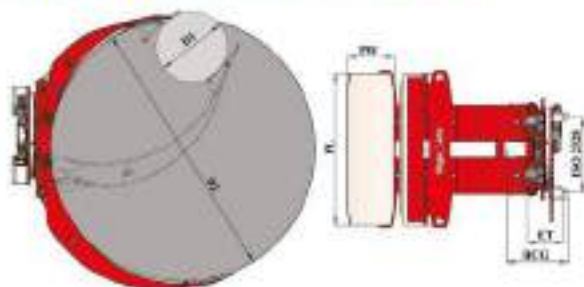

Catalogue Order No	Part No	Capacity (kg/m)	Roll Range (mm)	Sheet Arm	Mounting Class	Pad Size (mm)	Effective Thickness (mm)	Horizontal Centre of Gravity (mm)	Weight (kg)	Price
			B1-B2	D1	ISO2328	PW-PL	ET	BCG	W	€
016PRT-A04HZ	PRT162516	1600/800	250-1600	variable	2A	300-1200	261	420	712	
016PRT-A06SZ	PRT164616	1600/800	460-1600	fixed	2A	300-1200	261	420	684	
016PRT-A08HY	PRT142518	1400/900	250-1800	variable	2A	300-1200	261	458	748	
016PRT-A08SY	PRT144618	1400/900	460-1800	fixed	2A	300-1200	261	458	726	
020PRT-B081Y	PRT202519	2000/900	250-1800	variable	2A/3A	300-1300	276	464	865	
020PRT-B08SY	PRT204619	2000/900	460-1800	fixed	2A/3A	300-1300	276	464	838	
020PRT-B100Y	PRT182520	1800/1000	250-2000	variable	2A/3A	300-1300	276	502	996	
020PRT-B10SP	PRT184620	1800/1000	460-2000	fixed	2A/3A	300-1300	276	502	962	
020PRT-B100Y	PRT262520	2600/1000	250-2000	variable	3A	400-1500	291	526	1265	
020PRT-B10SP	PRT264620	2600/1000	460-2000	fixed	3A	400-1500	291	526	1228	
020PRT-B12HT	PRT232522	2300/1100	250-2200	variable	3A	400-1500	291	598	1380	
020PRT-B12ST	PRT234622	2300/1100	460-2200	fixed	3A	400-1500	291	598	1344	

- 360° rotating paper roll clamp for vertical and horizontal handling of single rolls.
- Sheet arm that can be adjusted only 45°.
- 2 hydraulic function.
- Side shift feature is not available.
- The quick release feature is optional.



PRT PAPER ROLL CLAMPS

360° Rotating Tissue Paper Roll Clamps

Wagner
attachmores

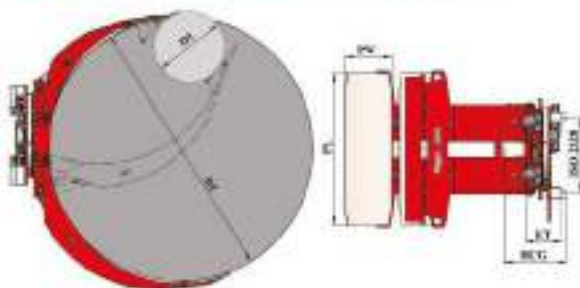

Catalogue Order No	Part No	Capacity (kg/mm)	Roll Range (mm)	Short Arm	Mounting Class	Pad Size (mm)	Effective Thickness (mm)	Horizontal Centre of Gravity (mm)	Weight (kg)	Price
			B1-D2	0°	ISO228	FW-PL	ET	HCG	W	€
830PRT-B10HP	PRT302520	3000/1000	250-2000	variable	3A	400-1400	296	544	1308	
830PRT-B10SP	PRT304620	3000/1000	460-2000	fixed	3A	400-1400	296	544	1276	
830PRT-B12HT	PRT282522	3800/1100	250-2200	variable	3A	400-1400	296	600	1398	
830PRT-B12ST	PRT284622	3800/1100	460-2200	fixed	3A	400-1400	296	600	1362	
840PRT-C13IX	PRT402527	4000/1150	250-2300	variable	3A/4A	400-1500	306	565	1785	
840PRT-C13SX	PRT404627	4000/1150	460-2300	fixed	3A/4A	400-1500	306	565	1748	
840PRT-C15HQ	PRT362524	3600/1250	250-2500	variable	3A/4A	400-1500	306	617	1876	
840PRT-C15SQ	PRT364624	3600/1250	460-2500	fixed	3A/4A	400-1500	306	617	1842	
850PRT-C13IX	PRT502523	5000/1150	250-2300	variable	4A	400-1800	311	582	2135	
850PRT-C13SX	PRT504623	5000/1150	460-2300	fixed	4A	400-1800	311	582	2096	
850PRT-C15HQ	PRT452525	4500/1250	250-2500	variable	4A	400-1800	311	643	2250	
850PRT-C15SQ	PRT454625	4500/1250	460-2500	fixed	4A	400-1800	311	643	2212	

- 360° rotating paper roll clamp for vertical and horizontal handling of single rolls.
- Short arm that can be adjusted only 45°.
- 2 hydraulic function.
- Side shift feature is not available.
- The quick release feature is optional.



PRR PAPER ROLL CLAMPS

Non-Rotating Paper Roll Clamps

Wagger®
attachments

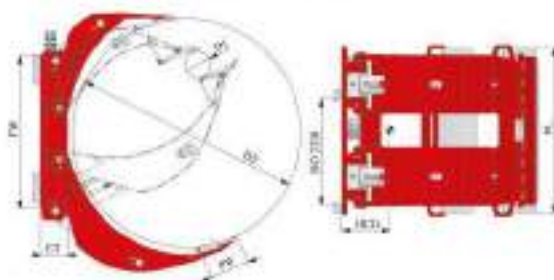

Catalogue Order No	Part No	Capacity (kg/mm)	Roll Range (mm)	Chassis Width	Mounting Class	Post Size (mm)	Effective Thickness (mm)	Horizontal Centre of Gravity (mm)	Weight (kg)	Price
			D1-D2	PW	EM2328	PW-PL	EE	HCL	W	€
018PRR-A08DR	PRR104014	1000/500	400-1000	1000	2A	240-700	96	283	394	
014PRR-A08DR	PRR144014	1400/500	400-1000	1000	2A	240-700	96	290	440	
018PRR-A06DR	PRR184518	1800/500	450-1600	1000	2A	240-700	96	290	485	
023PRR-B06DM	PRR234518	2300/500	450-1600	1000	2A/3A	240-700	101	324	510	
026PRR-B08DM	PRR265518	2600/500	550-1800	1100	2A/3A	240-700	101	352	596	
038PRR-B08DM	PRR385518	3000/500	550-1800	1100	3A	240-700	106	348	663	
035PRR-C10DE	PRR356020	3500/600	600-2000	1200	3A/4A	240-660	116	385	698	

- Non-rotating paper roll clamp for vertical handling of single rolls.
- 1 hydraulic function.
- Side shift feature add-on valve. (Requires additional hydraulic function)
- The quick release feature is optional.



Wagner[®]

attachments

THINK BIG!

HOLD THE WORLD

Rotators

RBG	360° Rotators	2-1
RBC	360° Rotators	2-2
RBU-TZ	360° Rotators	2-3
RBU	90° Rotators	2-4
RBX-A	360° Rotators With Hydraulic Bin Retainer	2-5
RBX-F	180° Rotators With Hydraulic Bin Retainer	2-6
RBX-R	180° Rotators With Hydraulic Bin Retainer	2-7
RBX-C	180° Rotators With Prehensile Arm	2-8



Waggen



Xseries

Rotators
Attachments



WARNING
AVOID INJURY
OR DEATH
Keep 10 feet (3m)
away from machine
and attachment
when in use.



RBG ROTATORS

360° Rotators

Wagner®
attachments

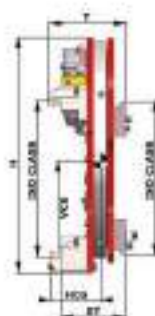

Catalogue Order No	Part No	Capacity (kg/ton)	Fork Carriage Width (mm)	Mounting Class	Rotating Torque	Effective Thickness (mm)	Horizontal Centre of Gravity (mm)	Weight (kg)	Price
			CW	ISO 1328	KN on 140bar	ET	HCG	W	€
01RRBG-A1040	RBG181040	1800/500	1040	2A	5.5	217	133	282	
020RBG-A1080	RBG201080	2000/500	1080	2A	5.5	217	133	284	
025RBG-A1100	RBG251100	2500/500	1100	2A	6.8	217	133	286	
032RBG-B1200	RBG321200	3200/500	1200	3A	8.5	217	133	337	
055RBG-B1200	RBG351200	3500/500	1200	3A	8.5	222	143	387	
040RBG-B1250	RBG401250	4000/500	1250	3A	9.8	237	151	431	
046RBG-B1300	RBG461300	4600/500	1300	3A	9.8	242	155	469	
050RBG-B1350	RBG501350	5000/500	1350	3A	16	249	158	633	
050RBG-C1400	RBG501400	5000/600	1400	4A	16	254	159	674	
055RBG-C1500	RBG551500	5500/600	1500	4A	16	259	125	824	

- This attachment, has continuous 360° rotation in both directions.
- Available for heavy duty.
- Attachment sell without forks. You can use forklift's own forks.
- 1 hydraulic function.
- The forks are manually adjustable and can be locked in position.
- Side shift feature is not available.



RBC ROTATORS

180° Rotators

Wagger®
attachments

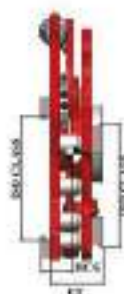

Catalogue Order No	Part No	Capacity (kg/arm)	Fork Carriage Width (mm)	Mounting Class	Rotating Torque	Effective Thickness (mm)	Horizontal Centre of Gravity (mm)	Weight (kg)	Price
014RBC-A1040	RBC361040	1600/500	1040	2A	-	232	104	254	
020RBC-A1080	RBC302080	2000/500	1080	2A	-	232	108	281	
025RBC-A1100	RBC251100	2500/500	1100	2A	-	232	113	298	
010RBC-B1200	RBC301280	3000/500	1200	3A	-	232	122	335	

- This attachment, has 180° rotation in one directions.
- Attachment sell without forks. You can use forklift's own forks.
- 1 hydraulic function.
- The forks are manually adjustable and can be locked in position.
- Side shift feature is not available.



RBU-12 ROTATORS

120° Rotators

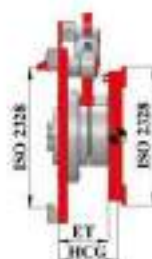

Catalogue Order No	Part No	Capacity (kg/mm)	Fork Carriage Width (mm)	Mounting Class	Rotating Torque	Effective Thickness (mm)	Horizontal Centre of Gravity (mm)	Weight (kg)	Price
			FCW	ISO 2328	kNm @ 1400bar	ET	HCG	W	€
025RBU12-A1100	RBU122511	1500/500	1100	2A	-	199	102	310	
015RBU12-B1200	RBU123512	1500/500	1200	3A	-	190	104	345	

- This attachment, has 120° rotation in one directions. Attachment sell without forks. You can use forklift's own forks.
- 1 hydraulic function.
- Side shift feature is not available.



RBU ROTATORS

90° Rotators

Wagner®
attachments

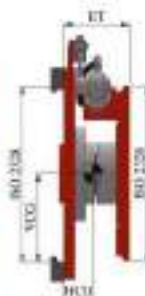
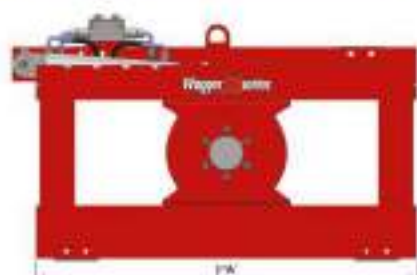

Catalogue Order No	Part No	Capacity (kg/mm)	Fork Carriage Width (mm)	Mounting Class	Raising Torque	Effective Thickness (mm)	Horizontal Centre of Gravity (mm)	Weight (kg)	Price
		CM	ISO 2328	kN.m/140Bar	ET	HCC	W	€	
025RBU9-A1100	RBU092511	2500/500	1100	2A	-	199	85	120	
035RBU9-B1200	RBU093512	3500/500	1200	3A	-	190	85	155	

- This attachment, has 90° rotation in one directions.
- Attachment sell without forks. You can use forklift's own forks.
- 1 hydraulic function.
- Side shift feature is not available.



RBX-A ROTATORS

360° Rotators With Hydraulic Bin Retainer

Wagner
attachments

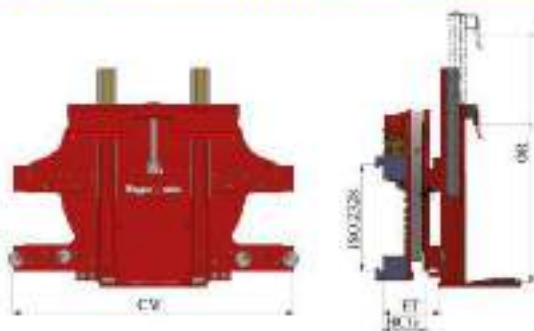

Catalogue Order No	Part No	Capacity on Forks (kg/mm)	Capacity on Rotating (kg/mm)	Fork Carriage Width (mm)	Opening Range (mm)	Mounting Class	Effective Thickness (mm)	Horizontal Centre of Gravity (mm)	Weight (kg)	Price
				CW	OR	ISO 1128	ET	HCG	W	€
022RBXA-A4277	RBXA224277	2200/500	3600/500	1070	420-770	2A	250	184	368	
022RBXA-A6297	RBXA226297	2200/500	3600/500	1070	620-970	2A	250	184	368	
030RBXA-B4277	RBXA304277	3000/500	3000/500	1100	420-770	3A	260	205	375	
030RBXA-B6297	RBXA306297	3000/500	3000/500	1100	620-970	3A	260	205	375	

- This attachment, has continuous 360° rotation in both directions.
- Attachment sell without forks. You can use forklift's own forks.
- 2 hydraulic function.
- The forks are manually adjustable and can be locked in position.
- Side shift feature is not available.
- Pressure adjustment valve available.



RBX-F ROTATORS

180° Rotators With Hydraulic Bin Retainer

Wagner
Attachments

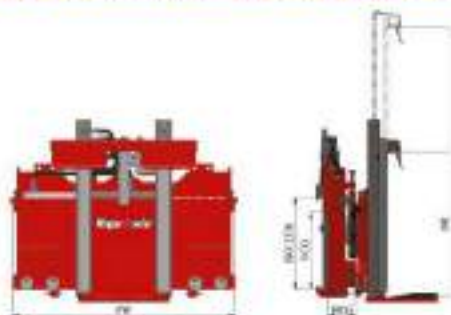

Catalogue Order No	Part No	Capacity on Fork (kg/mm)	Capacity in Rotating (kg/mm)	Fork Carriage Width (mm)	Opening Range (mm)	Moulding Class	Effective Thickness (mm)	Horizontal Centre of Gravity (mm)	Weight (kg)	Price
				FW	OR	ISO 2128	ET	ECG	W	€
016RBXF-A40	RBXF164910	1600/500	1200/500	1070	400 - 740	2A	322	142	328	
016RBXF-A60	RBXF166910	1600/500	1200/500	1070	600 - 940	2A	322	142	330	
016RBXF-B40	RBXF164911	1600/500	1200/500	1100	400 - 740	3A	322	148	342	
016RBXF-B60	RBXF166911	1600/500	1200/500	1100	600 - 940	3A	322	148	344	
020RBXF-A40	RBXF204910	2000/500	1600/500	1070	400 - 740	2A	327	146	334	
020RBXF-A60	RBXF206910	2000/500	1600/500	1070	600 - 940	2A	327	146	336	
020RBXF-B40	RBXF204911	2000/500	1600/500	1100	400 - 740	3A	327	152	348	
020RBXF-B60	RBXF206911	2000/500	1600/500	1100	600 - 940	3A	327	152	350	

- This attachment, has 180° rotation in one directions.
- Attachment sell without forks. You can use forklift's own forks.
- 3 movements with 1 hydraulic function.
- The forks are manually adjustable and can be locked in position.
- Side shift feature is not available.
- Pressure adjustment valve available.



RBX-R ROTATORS

180° Rotators With Hydraulic Bin Retainer

Wagner
attachments

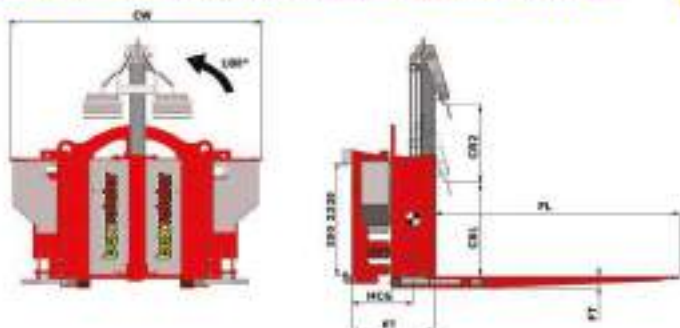

Catalogue Order No	Part No	Capacity on Fork (kg/mm)	Capacity in Rotating (kg/mm)	Fork Carriage Width (mm)	Opening Range (mm)	Mounting Class	Effective Thickness (mm)	Horizontal Centre of Gravity (mm)	Weight (kg)	Price
				C/W	CR1 - CR2	ISO 2328	ET	HCG	W	€
016RBXR.A40	RBXR160010	1600/500	1300/500	665	400-765	2A/3A	374	269	362	
016RBXR.A60	RBXR160010	1600/500	1300/500	665	600-940	2A/3A	374	269	365	
020RBXR.B40	RBXR200010	2000/500	1600/500	665	400-765	2A/3A	376	270	385	
020RBXR.B60	RBXR200010	2000/500	1600/500	665	600-940	2A/3A	376	270	389	

- This attachment, has 180° rotation in one direction.
- Attachment sell without forks. You can use forklift's own forks.
- 2 movements with 1 hydraulic function.
- Side shift feature is not available.
- Pressure adjustment valve available.



RBX-C ROTATORS

180° Rotators With Prehensile Arm

Wagger®
attachments



Catalogue Order No	Part No	Capacity (kg/mm)	Capacity in Rotating (kg/mm)	Fork Carriage Width (mm)	Mounting Class	Effective Thickness (mm)	Horizontal Centre of Gravity (mm)	Weight (kg)	Price
				FCW	ISO 2328	ET	HCG	W	C
014RBXC-A16	RBXC161293	1600/500	1200/500	930	2A/3A	276	248	275	
024RBXC-B20	RBXC201493	2000/500	1600/500	930	2A/3A	281	153	289	

- This attachment, has 180° rotation in one directions.
- Locking system with arm.
- Attachment sell without forks. You can use forklift's own forks. 2 movements with 1 hydraulic function.
- Side shift feature is not available.
- Pressure adjustment valve available.



Wagner[®]

attachments

THINK BIG!

HOLD THE WORLD

Rotating Clamps

Pallet Inverter

CPT	360° Rotating Fork Clamps	3-1
CPR	Non-Rotating Pallet Inverter Clamps	3-2





Waggen **X** series

| 3



Rotating Clamps
Pallet inverter

CPT ROTATING CLAMPS & PALLET INVERTER

360° Rotating Fork Clamps

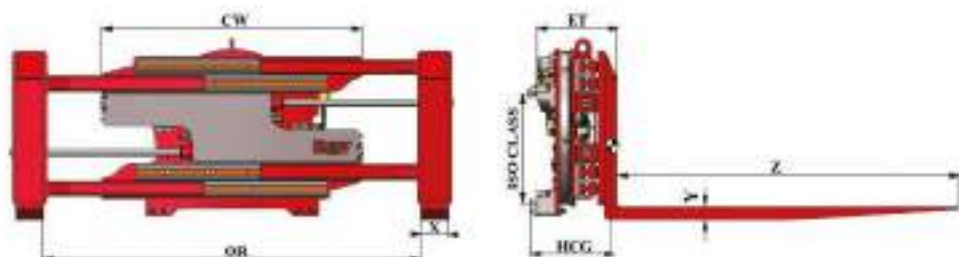

Catalogue Order No	Part No	Capacity (kg/mm)	Opening Range (mm)	Chassis Width (mm)	Mounting Class	Fork Section (mm)	Effective Thickness (mm)	Horizontal Centre of Gravity (mm)	Weight (kg)	Price
			OR	CW	ISO2128	X / Y / Z	ET	HCG	W	€
022CPT A02GJ	CPT215011	1200/500	500-1850	1200	2A/3A	125x45x1200	372	268	646	
022CPT A03GJ	CPT216029	1200/500	600-2000	1200	2A/3A	125x45x1200	372	268	648	
026CPT B02GJ	CPT265011	1600/500	500-1850	1400	3A	125x50x1200	372	273	678	
026CPT B03GJ	CPT266029	1600/500	600-2000	1400	3A	125x50x1200	372	273	680	

- This attachment, has continuous 360° rotation in both directions.
- Including forks. The forks are hydraulically adjustable.
- 2 hydraulic function.
- Side shift feature is not available.
- Pressure adjustment valve is optional.



CPR ROTATING CLAMPS & PALLET INVERTER

360° Rotating Pallet Inverter Clamps

Wagner®
attachments

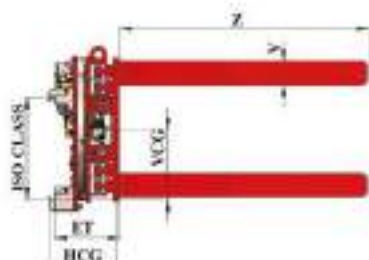
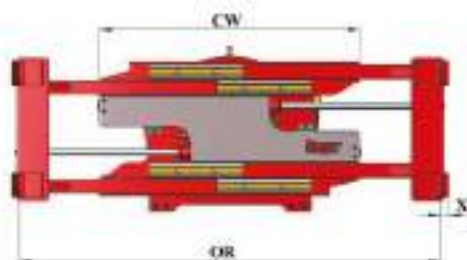

Catalogue Order No	Part No	Capacity (kg/ton)	Opening Range (mm)	Chassis Width (mm)	Mounting Class	Fork Section (mm)	Height (mm)	Effective Thickness (mm)	Horizontal Centre of Gravity (mm)	Weight (kg)	Price
			OR	CW	D02J28	X / Y / Z	H	ET	HCG	W	€
022CPR-A03GJ	CPR225519	2200/100	550-1900	1200	3A/3A	125x45x1200	690	357	321	678	
022CPR-A07GJ	CPR226620	2200/100	600-2000	1200	3A/3A	125x45x1200	690	357	321	680	
026CPR-B03GJ	CPR265519	2600/100	550-1900	1400	3A	125x50x1200	690	362	328	710	
026CPR-B07GJ	CPR266620	2600/100	600-2000	1400	3A	125x50x1200	690	362	328	712	

- This attachment, has continuous 360° rotation in both directions.
- Pallet inverter are used for turning goods during the production process, for example, for turning coated boards upside down or for changing pallets
- Including forks. The forks are hydraulically adjustable.
- 2 hydraulic function.
- Side shift feature is not available.
- Pressure adjustment valve is optional.



Wagger[®]

attachments

THINK BIG!
HOLD THE WORLD

Side Shifters

Fork Positioners

YKX	Hook-On Side Shifters - S Profil / 2 - 4 Ton	4-1
YKZ	Hook-On Side Shifters - Heavy Duty / 4,5 - 8 Ton	4-2
FRN	Fork Positioners With Side Shifter	4-3
FPN	Heavy Duty Fork Positioners With Side Shifters	4-4
FPN-C	Heavy Duty Fork Positioners With Side Shifters And	4-5
FAR	360° Rotating Forks Positioners	4-6



ger X series



Wagner **X** series



side shifters
Fork Positioners

YKX SIDE SHIFTER & FORK POSITIONERS

Hook-On Side Shifters - S Profil / 2-4 Ton

Wagner
attachments



Catalogue Order No	Part No	Capacity (kg/ton)	Side Shift Stroke (mm)	Channel Width (mm)	Mounting Class	Effective Thickness (mm)	Horizontal Centre of Gravity (mm)	Weight (kg)	Price
		S	CW	ISO228	ET	HCG	W	€	
020YKX-A928	YKX286928	2000/500	100+100	920	2A	57	23	44	
020YKX-A976	YKX286976	2000/500	100+100	970	2A	57	23	47	
020YKX-A1040	YKX281040	2000/500	100+100	1040	2A	57	23	51	
025YKX-A1040	YKX251040	2500/500	100+100	1040	2A	58	24	52	
025YKX-A1060	YKX251060	2500/500	100+100	1060	2A	58	24	53	
025YKX-A1190	YKX251190	2500/500	100+100	1190	2A	58	24	54	
025YKX-A1150	YKX251150	2500/500	100+100	1150	2A	58	24	55	
035YKX-B1060	YKX351060	3500/500	100+100	1060	3A	63	26	74	
035YKX-B1100	YKX351100	3500/500	100+100	1100	3A	63	26	77	
035YKX-B1200	YKX351200	3500/500	100+100	1200	3A	63	26	82	
035YKX-B1300	YKX351300	3500/500	100+100	1300	3A	63	26	87	
040YKX-B1190	YKX401190	4000/500	100+100	1190	3A	65	24	85	
040YKX-B1250	YKX401250	4000/500	100+100	1250	3A	65	24	90	
040YKX-B1300	YKX401300	4000/500	100+100	1300	3A	65	24	94	
040YKX-B1350	YKX401350	4000/500	100+100	1350	3A	65	24	98	

- To move the load to the left or right without moving the forklift.
- S profile was used in production.
- 1 hydraulic function.
- Load backrest and forks are excluded.
- 100 mm side shift stroke.





Catalogue Order No	Part No	Capacity (kg/mm)	SideShift Stroke (mm)	Chassis Width (mm)	Mounting Class	Effective Thickness (mm)	Horizontal Centre of Gravity (mm)	Weight (kg)	Price
			S	CW	ISO2328	ET	HCG	W	€
04FYKZ-01250	YK2451250	4500/500	150+150	1250	3A	82	37	148	
045YKZ-01350	YK2451350	4500/500	150+150	1350	3A	82	37	175	
050YKZ-01250	YK2501250	5000/500	150+150	1250	3A	83	39	173	
050YKZ-01350	YK2501350	5000/500	150+150	1350	3A	83	39	182	
050YKZ-C1270	YK2501230	5000/600	150+130	1250	4A	85	39	243	
050YKZ-C1330	YK2501350	5000/600	150+130	1350	4A	83	39	252	
050YKZ-C1400	YK2501400	5000/600	150+150	1400	4A	85	39	261	
060YKZ-C1500	YK2601500	6000/600	150+150	1500	4A	84	45	270	
060YKZ-C1600	YK2601600	6000/600	150+150	1600	4A	84	45	281	
060YKZ-C1700	YK2601700	6000/600	150+150	1700	4A	84	45	290	
070YKZ-C1700	YK2701700	7000/600	150+150	1700	4A	85	46	296	
070YKZ-C1800	YK2701800	7000/600	150+150	1800	4A	85	46	305	
070YKZ-C2000	YK2702000	7000/600	150+150	2000	4A	85	46	326	
080YKZ-C1800	YK2801800	8000/600	150+150	1800	4A	95	51	339	
080YKZ-C2000	YK2802000	8000/600	150+150	2000	4A	95	51	358	
080YKZ-C2100	YK2802100	8000/600	150+150	2100	4A	95	51	371	
090YKZ-C2200	YK2802200	8000/600	150+150	2200	4A	95	51	382	

- To move the load to the left or right without moving the forklift.
- For heavy duty.
- 1 hydraulic function.
- Load backrest and forks are excluded.
- 150 mm side shift stroke.



FRN SIDE SHIFTER & FORK POSITIONERS

Fork Positioners With Side Shifters

Wagner
attachments



Catalogue Order No	Part No	Capacity (kg/ton)	Opening flange (mm)	Chassis Width (mm)	Mounting Class	Height	Effective Thickness (mm)	Horizontal Centre of Gravity (mm)	Weight (kg)	Price
			OR	CW	ISO1128	D	ET	HCG	W	€
020FRN-A1140	FRN201100	2000/500	320-950	1100	2A	710	100	40	112	
025FRN-A1150	FRN251150	2500/500	320-1000	1150	2A	710	100	40	118	
035FRN-B1200	FRN351200	3500/500	320-1050	1200	3A	815	104	43	145	
040FRN-B1250	FRN401250	4000/500	320-1100	1250	3A	815	104	43	156	

- You may use it to position forks for pallet dimension.
- 2 hydraulic function.
- With separate side shift.
- Load backrest and forks are excluded.



FPN SIDE SHIFTER & FORK POSITIONERS

Heavy Duty Fork Positioners With Side Shifters

Wagner[®]
attachments

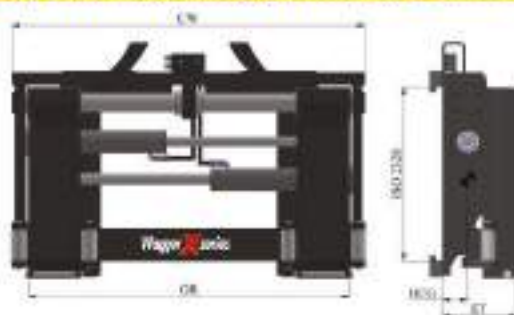

Catalogue Order No	Part No	Capacity (kg/mm)	Opening Range (mm)	Characteristic Width (mm)	Mounting Class	Effective Thickness (mm)	Horizontal Centre of Gravity (mm)	Weight (kg)	Price
020FPN-A1060	FPN201060	2000/590	340-980	1060	2A	143	60	165	
025FPN-A1100	FPN251100	2500/590	340-1000	1100	2A	145	61	174	
035FPN-B1200	FPN351200	3500/590	385-1085	1200	3A	170	69	260	
040FPN-B1250	FPN401250	4000/590	385-1125	1250	3A	181	72	276	
045FPN-B1300	FPN451300	4500/590	385-1185	1300	3A	182	73	283	
050FPN-B1350	FPN501350	5000/590	440-1190	1350	3A	184	75	325	
050FPN-C1450	FPN501450	5000/690	480-1300	1450	4A	250	97	541	
060FPN-C1600	FPN601600	6000/690	480-1430	1600	4A	260	102	648	
070FPN-C1800	FPN701800	7000/690	480-1630	1800	4A	260	105	678	
080FPN-C2100	FPN802100	8000/690	480-1930	2100	4A	260	106	732	

- You may use it to position forks for pallet dimension
- For heavy duty.
- 2 hydraulic function.
- Side shift feature available.
- Load backrest and forks are excluded.



FPN-C SIDE SHIFTER & FORK POSITIONERS

Heavy Duty Fork Positioners With Side Shifters And Forks

Wagger®
attachworks

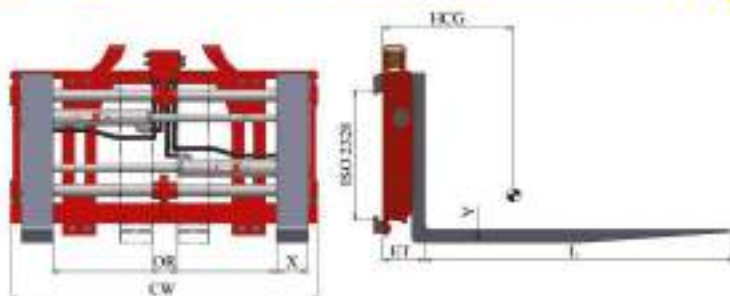

Catalogue Order No	Part No	Capacity (kg/mm)	Opening Range (mm)	Chassis Width (mm)	Fork Section (mm)	Mounting Class	Effective Thickness (mm)	Horizontal Centre of Gravity (mm)	Weight (kg)	Price
			OR	CW	X / Y / Z	ISO228	ET	HCG	W	£
025FPNC-A1100	FPNC251100	2500/500	85-740	1100	125/45/1200	2A	145	237	274	
035FPNC-B1200	FPNC351200	3500/500	102-870	1200	125/50/1200	3A	163	221	353	
065FPNC-C1350	FPNC451350	4500/600	105-960	1350	125/50/1200	4A	176	204	412	

- You may use it to position forks for pallet dimension.
- For heavy duty.
- 2 hydraulic function.
- Side shift feature available.
- With forks.
- Load backrest excluded.



FAR SIDE SHIFTER & FORK POSITIONERS

360° Rotating Fork Positioners

Wagner®
attachments

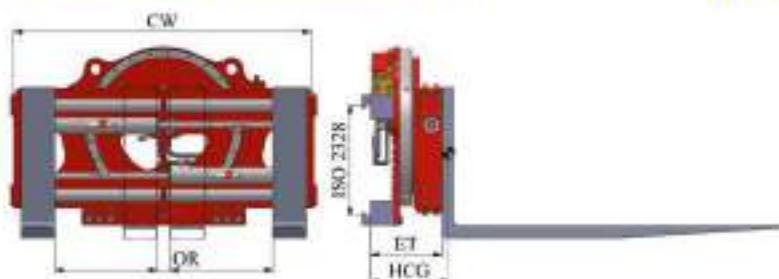

Catalogue Order No	Part No	Capacity (kg/mm)	Opening Range (mm)	Chassis Width (mm)	Mounting Class	Effective Thickness (mm)	Horizontal Centre of Gravity (mm)	Weight (kg)	Price
			OM	CW	ISO2328	ET	HCG	W	€
020FAR-A1100	FAR201100	2000/500	100-1030	1100	2A	260	157	445	
026FAR-B1200	FAR261200	2600/500	100-1130	1200	3A	286	178	585	
032FAR-B1250	FAR321250	3200/500	100-1180	1250	3A	313	183	798	

- This attachment, has continuous 360° rotation in both directions.
- 2 hydraulic function.
- Side shift feature is not available.
- With forks.



Wagner[®]

attachments

THINK BIG!

HOLD THE WORLD

Bale Clamps

CAP	Cotton Bale Clamps	5-1, 5-6
CBA	Recycling Bale Clamps	5-7
CSA	Cellulose Bale Clamps	5-8
CSR	Tobacco Clamps	5-9
CSR-L	Tobacco Clamps - Long Arm	5-10
CFB	Foam Rubber Clamps	5-11
CTC	Pole Tine Clamps	5-12
CAN	Fork Clamps	5-13
CFP	Fork Clamps With Manually Turnable Forks	5-14





Custom Bale
Clamps

Waggen
attachments



Turnable Fork
Clamps



Custom Bale
Clamps

Waggen
attachments



Turnable Fork
Clamps

CAP BALE CLAMPS

Cotton Bale Clamps

Wagger®
attachment/18

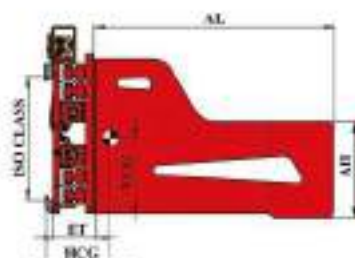
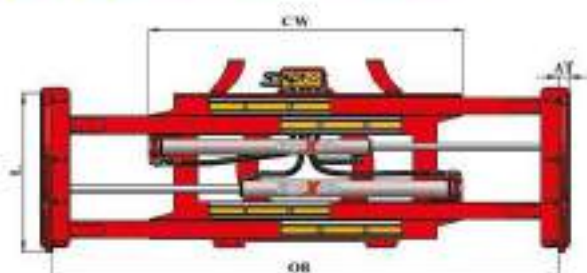

Catalogue Order No	Part No	Capacity (kg/min)	Opening Range (mm)	Chassis Width (mm)	Mounting Class	Arm Dimensions (mm)	Effective Thickness (mm)	Horizontal Centre of Gravity (mm)	Weight (kg)		Price
									W	L	
			OH	CW	ISO238	A/L/H/T	ET	HCG	W	L	
010CAP-A01GI	CAP104015	1000/500	400-1500	1000	2A	1000/530/350/45	96	203	302		
010CAP-A02GI	CAP104716	1000/500	475-1600	1000	2A	1000/530/350/45	96	202	303		
010CAP-A03GI	CAP104817	1000/500	480-1770	1100	2A	1000/530/350/45	96	270	316		
010CAP-A12GI	CAP105618	1000/500	565-1800	1100	2A	1000/530/350/45	96	269	317		
010CAP-A06GI	CAP104919	1000/500	495-1900	1200	2A	1000/530/350/45	96	237	332		
010CAP-A11GI	CAP105620	1000/500	560-2030	1200	2A	1000/530/350/45	96	236	333		
014CAP-A06GI	CAP144919	1400/500	495-1900	1200	2A	1000/530/350/45	111	265	413		
014CAP-A11GI	CAP145620	1400/500	560-2030	1200	2A	1000/530/350/45	111	264	414		
014CAP-A12GI	CAP145921	1400/500	590-2100	1200	2A	1000/530/350/45	111	263	415		
014CAP-A05GI	CAP144920	1400/500	490-2000	1300	2A	1000/530/350/45	111	230	438		
014CAP-A09GI	CAP145521	1400/500	530-2130	1300	2A	1000/530/350/45	111	248	439		

- This attachment is used for loading, unloading or stacking cotton and wool bales.
- 2 hydraulic function.
- Side shift feature available.
- Optional ;
 - Quick release,
 - Load backrest,
 - Pressure adjustment valve,
 - Special opening ranges,
 - Arms of different diameters.



CAP BALE CLAMPS

Cotton Bale Clamps

Wagger®
attachments

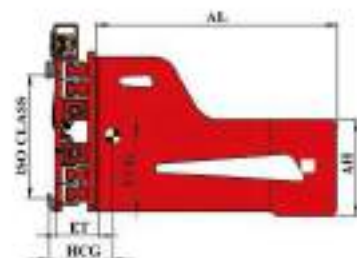
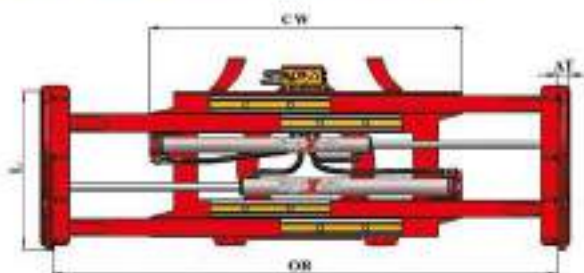

Catalogue Order No	Part No	Capacity (kg/mm)	Opening Range (mm)	Chassis Width (mm)	Mowing Class	Arm Dimensions (mm)	Effective Thickness (mm)	Horizontal Centre of Gravity (mm)	Weight (kg)	Price
			OR	CW	ISO2328	A / L / H / T	ET	HCG	W	€
020CAP-A06GI	CAP204919	2000/500	495-1900	1200	2A	1000/530/350/45	121	255	445	
020CAP-A11GI	CAP205620	2000/500	560-2070	1200	2A	1000/530/350/45	121	254	446	
020CAP-A05GI	CAP204920	2000/500	490-2000	1300	2A	1000/530/350/45	121	242	469	
020CAP-A09GI	CAP205521	2000/500	550-2130	1300	2A	1000/530/350/45	121	241	470	
020CAP-A19GI	CAP206022	2000/500	600-2230	1300	2A	1000/530/350/45	121	240	470	
020CAP-A15GI	CAP206523	2000/500	650-2330	1300	2A	1000/530/350/45	121	240	471	
020CAP-A17GI	CAP207524	2000/500	750-2450	1300	2A	1000/530/350/45	121	238	472	
020CAP-A04GI	CAP204821	2000/500	485-2100	1400	2A	1000/530/350/45	121	224	496	
020CAP-A10GI	CAP205522	2000/500	555-2245	1400	2A	1000/530/350/45	121	225	497	
020CAP-A14GI	CAP206424	2000/500	640-2440	1400	2A	1000/530/350/45	121	221	498	
020CAP-A07GI	CAP205022	2000/500	500-2270	1550	2A	1000/530/350/45	121	198	548	
020CAP-A08GI	CAP205424	2000/500	545-2420	1550	2A	1000/530/350/45	121	197	550	
020CAP-A16GI	CAP206725	2000/500	670-2550	1550	2A	1000/530/350/45	121	197	551	

- This attachment is used for loading, unloading or stacking cotton and wool bales.
- 2 hydraulic function.
- Side shift feature available.
- Optional :
 - Quick release,
 - Load backrest,
 - Pressure adjustment valve,
 - Special opening ranges,
 - Arms of different dimensions.



CAP BALE CLAMPS

Cotton Bale Clamps

Wagger®
attachment/18

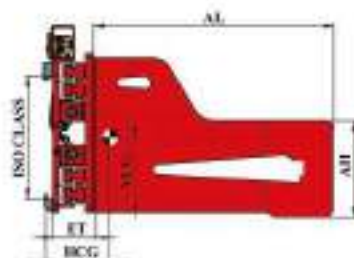
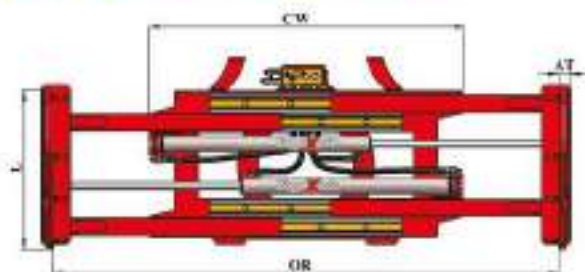

Catalogue Order No	Part No	Capacity (kg/m³)	Opening Range (mm)	Chainlink Width (mm)	Mounting Class	Arm Dimensions (mm)	Effective Thickness (mm)	Horizontal Centrifuge of Gravity (mm)	Weight (kg)	Price
023CAP-B06GI	CAP234919	2300/500	495-1960	1200	3A	1080/640/345/50	121	262	495	
023CAP-B11GI	CAP235620	2300/500	566-2030	1200	3A	1080/640/345/50	121	261	496	
023CAP-B05GI	CAP234920	2300/500	496-2060	1300	3A	1080/640/345/50	121	256	518	
023CAP-B09GI	CAP235521	2300/500	556-2130	1300	3A	1080/640/345/50	121	254	521	
023CAP-B19GI	CAP236022	2300/500	606-2230	1300	3A	1080/640/345/50	121	254	521	
023CAP-B15GI	CAP236523	2300/500	656-2330	1300	3A	1080/640/345/50	121	254	521	
023CAP-B17GI	CAP237524	2300/500	756-2450	1300	3A	1080/640/345/50	121	253	524	
023CAP-B04GI	CAP234825	2300/500	485-2180	1400	3A	1080/640/345/50	121	233	523	
023CAP-B10GI	CAP235522	2300/500	553-2245	1400	3A	1080/640/345/50	121	232	524	
023CAP-B14GI	CAP236424	2300/500	646-2440	1400	3A	1080/640/345/50	121	232	525	
023CAP-B07GI	CAP235022	2300/500	506-2270	1550	3A	1080/640/345/50	121	217	548	
023CAP-B08GI	CAP235424	2300/500	545-2420	1550	3A	1080/640/345/50	121	216	549	
023CAP-B16GI	CAP236725	2300/500	676-2550	1550	3A	1080/640/345/50	121	214	549	

- This attachment is used for loading, unloading or stacking cotton and wool bales.
- 2 hydraulic function.
- Side shift feature available.
- Optional ;
 - Quick release,
 - Load backrest,
 - Pressure adjustment valve,
 - Special opening ranges,
 - Arms of different diameters.



CAP BALE CLAMPS

Cotton Bale Clamps

Wagner®
attachments

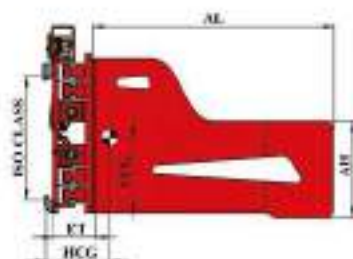
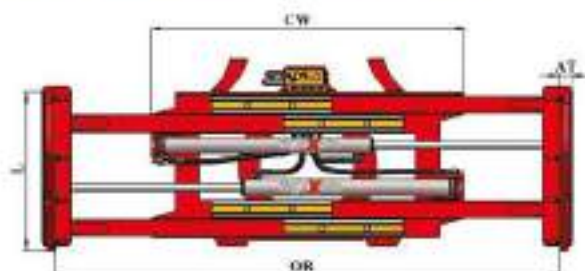

Catalogue Order No	Part No	Capacity (kg/ton)	Opening Range (mm)	Chassis Width (mm)	Mounting Class	Arm Dimensions (mm)	Effective Thickness (mm)	Horizontal Centre of Gravity (mm)	Weight (kg)		Price
									W	€	
			OR	CW	ISO2328	A / L / H / T	ET	HCG	W	€	
026CAP-B06GI	CAP264919	2600/500	495-1900	1200	3A	1000/640/345/50	114	275	547		
026CAP-B11GI	CAP265620	2600/500	560-2070	1200	3A	1000/640/345/50	114	274	549		
026CAP-B05GI	CAP264920	2600/500	490-2000	1200	3A	1000/640/345/50	114	268	568		
026CAP-B04GI	CAP265521	2600/500	550-2130	1300	3A	1000/640/345/50	114	267	569		
026CAP-B14GI	CAP266022	2600/500	600-2230	1300	3A	1000/640/345/50	114	267	570		
026CAP-B15GI	CAP266523	2600/500	650-2330	1300	3A	1000/640/345/50	114	266	571		
026CAP-B17GI	CAP267524	2600/500	750-2450	1300	3A	1000/640/345/50	114	266	572		
026CAP-B04GI	CAP264821	2600/500	485-2100	1400	3A	1000/640/345/50	114	246	584		
026CAP-B10GI	CAP265522	2600/500	555-2245	1400	3A	1000/640/345/50	114	245	586		
026CAP-B14GI	CAP266424	2600/500	640-2440	1400	3A	1000/640/345/50	114	245	588		
026CAP-B07GI	CAP265022	2600/500	500-2270	1550	3A	1000/640/345/50	114	251	601		
026CAP-B08GI	CAP265424	2600/500	545-2420	1550	3A	1000/640/345/50	114	229	603		
026CAP-B10GI	CAP266725	2600/500	670-2550	1550	3A	1000/640/345/50	114	226	605		

- This attachment is used for loading, unloading or stacking cotton and wool bales.
- 2 hydraulic function.
- Side shift feature available.
- Optional :
 - Quick release,
 - Load backrest,
 - Pressure adjustment valve,
 - Special opening ranges,
 - Arms of different dimensions.



CAP BALE CLAMPS

Cotton Bale Clamps

Wagger®
attachment

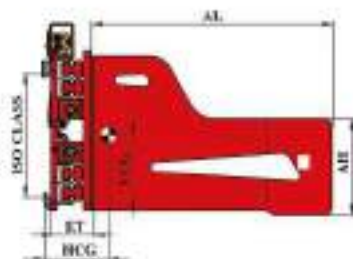
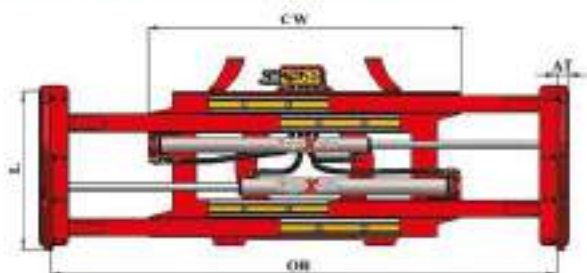

Catalogue Order No	Part No	Capacity (kg/m ³)	Opening Range (mm)	Chassis Width (mm)	Mounting Class	Arm Dimensions (mm)	Effective Thickness (mm)	Horizontal Centre of Gravity (mm)	Weight (kg)	Price
030CAP-B09GI	CAP305521	3000/500	550-2130	1300	3A	1000/640/345/50	139	262	597	
030CAP-B19GI	CAP306022	3000/500	600-2230	1300	3A	1000/640/345/50	139	262	598	
030CAP-B15GI	CAP306523	3000/500	650-2330	1300	3A	1000/640/345/50	139	299	599	
030CAP-B04GI	CAP304821	3000/500	485-2100	1400	3A	1000/640/345/50	139	239	612	
030CAP-B10GI	CAP305522	3000/500	555-2245	1400	3A	1000/640/345/50	139	218	613	
030CAP-B14GI	CAP306424	3000/500	640-2440	1400	3A	1000/640/345/50	139	236	617	
030CAP-B07GI	CAP305022	3000/500	500-2270	1550	3A	1000/640/345/50	139	224	625	
030CAP-B08GI	CAP305424	3000/500	545-2420	1550	3A	1000/640/345/50	139	222	629	
030CAP-B16GI	CAP306725	3000/500	670-2550	1550	3A	1000/640/345/50	139	221	631	

- This attachment is used for loading, unloading or stacking cotton and wool bales.
- 2 hydraulic function.
- Side shift feature available.
- Optional ;
 - Quick release,
 - Load backrest,
 - Pressure adjustment valve,
 - Special opening ranges,
 - Arms of different dimensions.



CAP BALE CLAMPS

Cotton Bale Clamps

Wagger®
attachments

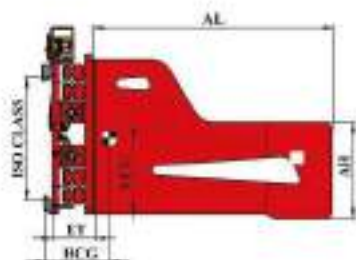
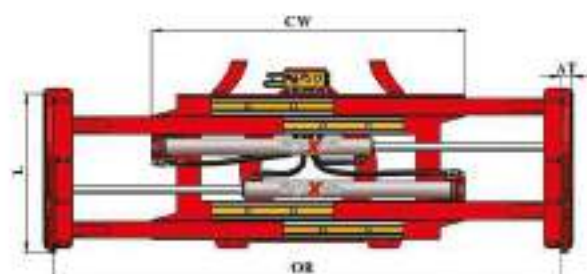

Catalogue Order No	Part No	Capacity (kg/mm)	Opening Range (mm)	Chassis Width (mm)	Mounting Class	Arm Dimensions (mm)	Effective Thickness (mm)	Horizontal Centre of Gravity (mm)	Weight (kg)	Price
			OR	CW	ISO2328	A / L / H / T	ET	HCG	W	C
046CAP-C09GI	CAP49552I	4000/600	550-2130	1300	4A	1206/800/520/55	142	310	828	
046CAP-C19GI	CAP496022	4000/600	600-2230	1300	4A	1206/800/520/55	142	310	829	
046CAP-C15GI	CAP496523	4000/600	650-2330	1300	4A	1206/800/520/55	142	309	831	
046CAP-C17GI	CAP497524	4000/600	750-2450	1300	4A	1206/800/520/55	142	307	833	
046CAP-C04GI	CAP49482I	4000/600	485-2100	1400	4A	1206/800/520/55	142	302	853	
046CAP-C10GI	CAP495522	4000/600	555-2245	1400	4A	1206/800/520/55	142	302	856	
046CAP-C14GI	CAP496424	4000/600	640-2440	1400	4A	1206/800/520/55	142	301	858	
046CAP-C07GI	CAP495022	4000/600	500-2270	1550	4A	1206/800/520/55	142	294	874	
046CAP-C08GI	CAP495424	4000/600	545-2420	1550	4A	1206/800/520/55	142	295	876	
046CAP-C16GI	CAP496725	4000/600	670-2550	1550	4A	1206/800/520/55	142	291	879	

- This attachment is used for loading, unloading or stacking cotton and wool bales.
- 2 hydraulic function.
- Side shift feature available.
- Optional :
 - Quick release,
 - Load backrest,
 - Pressure adjustment valve,
 - Special opening ranges,
 - Arms of different dimensions.



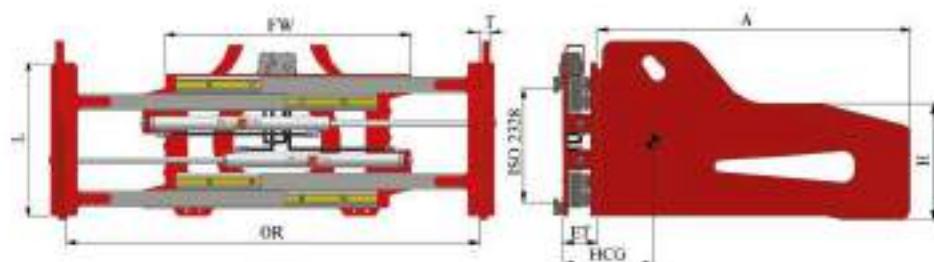

Catalogue Order No	Part No	Capacity (kg/m ³)	Opening Range (mm)	Chassis Width (mm)	Mounting Class	Arm Dimensions (mm)	Effective Thickness (mm)	Horizontal Centre of Gravity (mm)	Weight (kg)	
									W	F
			OR	CW	ISO2338	A / L / H / T	ET	HCG	W	F
020CBA-A05GJ	CBA204820	2090/500	490-2000	1300	2A	1200/550/400/50	111	249	516	
020CBA-A09GJ	CBA205521	2090/500	550-2130	1300	2A	1200/550/400/50	111	248	518	
020CBA-A19GJ	CBA206822	2090/500	600-2230	1300	2A	1200/550/400/50	111	248	518	
020CBA-A15GJ	CBA206523	2090/500	650-2330	1300	2A	1200/550/400/50	111	246	519	
020CBA-A17GJ	CBA207524	2090/500	750-2430	1300	2A	1200/550/400/50	111	244	523	
023CBA-A05GJ	CBA234820	2390/500	490-2000	1300	2A/3A	1200/650/450/50	121	268	542	
023CBA-A09GJ	CBA235521	2390/500	550-2130	1300	2A/3A	1200/650/450/50	121	268	544	
020CBA-A19GJ	CBA206822	2390/500	600-2230	1300	2A/3A	1200/650/450/50	121	268	545	
023CBA-A15GJ	CBA236523	2390/500	650-2330	1300	2A/3A	1200/650/450/50	121	267	547	
023CBA-A17GJ	CBA237524	2390/500	750-2430	1300	2A/3A	1200/650/450/50	121	265	549	
026CBA-B05GJ	CBA264820	2690/500	490-2000	1300	3A	1200/650/450/50	126	286	593	
026CBA-B09GJ	CBA265521	2690/500	550-2130	1300	3A	1200/650/450/50	126	285	595	
020CBA-A19GJ	CBA206822	2690/500	600-2230	1300	3A	1200/650/450/50	126	285	595	
026CBA-B15GJ	CBA266523	2690/500	650-2330	1300	3A	1200/650/450/50	126	283	596	
026CBA-B17GJ	CBA267524	2690/500	750-2430	1300	3A	1200/650/450/50	126	282	598	
030CBA-B15GJ	CBA306523	3090/500	650-2330	1300	3A	1200/650/450/55	139	278	634	
030CBA-B10GJ	CBA305522	3090/500	555-2245	1400	3A	1200/650/450/55	139	277	636	
030CBA-B16GJ	CBA306725	3090/500	670-2550	1550	3A	1200/650/450/55	139	274	637	
040CBA-C17GJ	CBA407524	4090/600	750-2430	1300	3A/4A	1400/900/550/60	142	406	982	
040CBA-C14GJ	CBA406424	4090/600	640-2440	1400	3A/4A	1400/900/550/60	142	404	985	
040CBA-C16GJ	CBA406725	4090/600	670-2550	1550	3A/4A	1400/900/550/60	142	401	987	

- This attachment is used for loading, unloading or stacking recycling bales.
- 2 hydraulic function.
- Side shift feature available.
- Optional :
 - Quick release,
 - Load backrest,
 - Pressure adjustment valve,
 - Special opening ranges,
 - Arms of different dimensions.



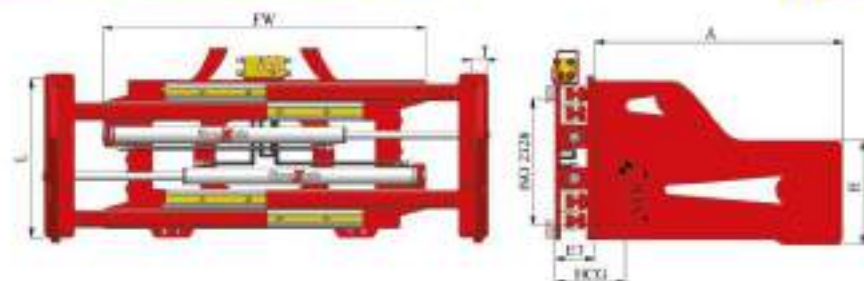

Catalogue Order No	Part No	Capacity (kg/ton)	Opening Range (mm)	Chassis Width (mm)	Mounting Class	Arm Dimensions (mm)	Effective Thickness (mm)	Horizontal Centre of Gravity (mm)	Weight (kg)	Price
									W	€
020CSA-A05GJ	CSA204920	2000/500	490-2000	1300	2A	1000/550/400/50	111	244	496	
020CSA-A09GJ	CSA205521	2000/500	550-2130	1300	2A	1000/550/400/50	111	243	498	
020CSA-A19GJ	CSA206022	2000/500	600-2230	1300	2A	1000/550/400/50	111	243	498	
020CSA-A15GJ	CSA206523	2000/500	650-2330	1300	2A	1000/550/400/50	111	241	499	
020CSA-A17GJ	CSA207524	2000/500	750-2450	1300	2A	1000/550/400/50	111	239	504	
025CSA-A05GJ	CSA234920	2300/500	490-2000	1300	2A/3A	1000/650/450/50	121	265	523	
025CSA-A09GJ	CSA235521	2300/500	550-2130	1300	2A/3A	1000/650/450/50	121	263	524	
020CSA-A19GJ	CSA206022	2300/500	600-2230	1300	2A/3A	1000/650/450/50	121	263	524	
025CSA-A15GJ	CSA236523	2300/500	650-2330	1300	2A/3A	1000/650/450/50	121	262	529	
025CSA-A17GJ	CSA237524	2300/500	750-2450	1300	2A/3A	1000/650/450/50	121	261	532	
026CSA-B05GJ	CSA264920	2600/500	490-2000	1300	2A/3A	1000/650/450/50	126	282	572	
026CSA-B09GJ	CSA265521	2600/500	550-2130	1300	2A/3A	1000/650/450/50	126	281	575	
020CSA-A19GJ	CSA206022	2600/500	600-2230	1300	2A/3A	1000/650/450/50	126	281	576	
026CSA-B15GJ	CSA266523	2600/500	650-2330	1300	2A/3A	1000/650/450/50	126	278	578	
026CSA-B17GJ	CSA267524	2600/500	750-2450	1300	2A/3A	1000/650/450/50	126	276	603	
030CSA-B15GJ	CSA306523	3000/500	650-2330	1300	3A	1200/650/450/55	139	271	611	
030CSA-B10GJ	CSA305522	3000/500	555-2245	1400	3A	1200/650/450/55	139	271	614	
030CSA-B16GJ	CSA306725	3000/500	670-2550	1550	3A	1200/650/450/55	139	269	616	
040CSA-C17GJ	CSA407524	4000/600	750-2450	1300	3A/4A	1200/900/550/60	142	376	957	
040CSA-C14GJ	CSA406424	4000/600	640-2440	1400	3A/4A	1200/900/550/60	142	375	959	
040CSA-C16GJ	CSA406725	4000/600	670-2550	1550	3A/4A	1200/900/550/60	142	372	962	

- This attachment is used for loading, unloading or stacking cellulose bales.
- 2 hydraulic function.
- Side shift feature available.
- Optional :
 - Quick release,
 - Load backrest,
 - Pressure adjustment valve,
 - Special opening ranges,



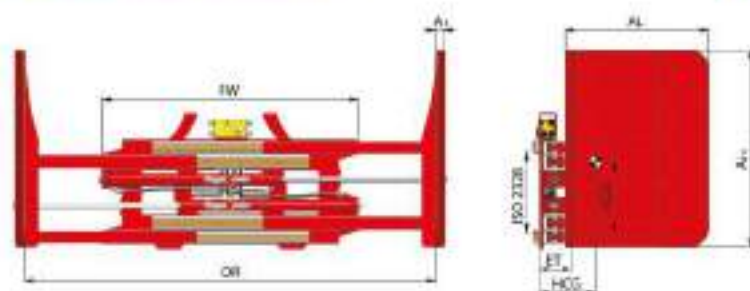

Catalogue Order No	Part No	Capacity (kg/m ³)	Opening Range (mm)	Chassis Width (mm)	Moulding Class	Arm Dimensions (mm)	Effective Thickness (mm)	Horizontal Centre of Gravity (mm)	Weight (kg)	Price
			DR	CW	ISO1328	A / H / T	ET	HCG	W	€
010CSR-A02GR	CSR104716	1000/500	475-1680	1000	2A	700/1000/25	96	268	182	
010CSR-A03GR	CSR104817	1000/500	480-1770	1190	2A	700/1000/25	96	267	304	
010CSR-A04GR	CSR104919	1000/500	495-1900	1200	2A	700/1000/25	96	256	411	
010CSR-A11GR	CSR105420	1000/500	560-2010	1200	2A	700/1000/25	96	255	414	
014CSR-A12GR	CSR145618	1400/500	565-1800	1190	2A	700/1000/25	111	262	422	
014CSR-A04GR	CSR144919	1400/500	495-1900	1200	2A	700/1000/25	111	241	434	
014CSR-A11GR	CSR145620	1400/500	560-2010	1200	2A	700/1000/25	111	240	436	
014CSR-A13GR	CSR145921	1400/500	590-2100	1200	2A	700/1000/25	111	237	439	

- This attachment is used for loading, unloading or stacking tobacco boxes.
- 2 hydraulic function.
- Side shift feature available.
- Optional ;
 - Quick release,
 - Load backrest,
 - Pressure adjustment valve,
 - Special opening ranges,
 - Arms of different dimensions.



CSR-L BALE CLAMPS

Tobacco Clamps - Long Arm

Wagger®
attachments

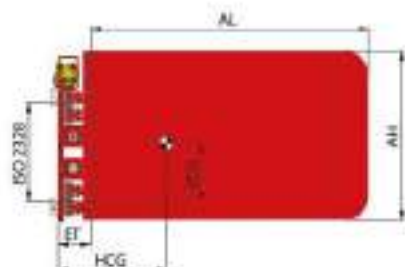
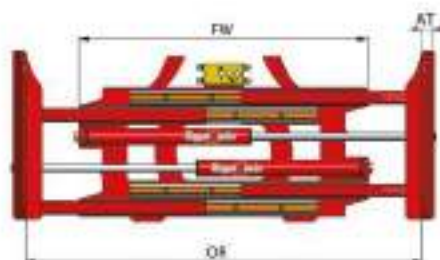

Catalogue Order No	Part No	Capacity (kg/m ²)	Opening Range (mm)	Chassis Width (mm)	Mounting Class	Arm Dimensions (mm)	Effective Thickness (mm)	Horizontal Centre of Gravity (mm)	Weight (kg)	Price
			OR	CW	ISO338	A/L/T	ET	HCG	W	€
010CSRL-A02GR	CSRL104716	1000/500	475-1600	1000	2A	800/1100/30	96	312	452	
010CSRL-A03GR	CSRL104817	1000/500	480-1770	1100	2A	800/1100/30	96	303	466	
010CSRL-A06GR	CSRL104919	1000/500	495-1900	1200	2A	800/1100/30	96	285	485	
010CSRL-A11GR	CSRL105620	1000/500	560-2030	1200	2A	800/1100/30	96	282	487	
014CSRL-A12GR	CSRL145618	1400/500	565-1800	1100	2A	800/1100/30	111	342	508	
014CSRL-A06GR	CSRL144919	1400/500	495-1900	1200	2A	800/1100/30	111	327	527	
014CSRL-A11GR	CSRL145620	1400/500	560-2030	1200	2A	800/1100/30	111	325	529	
014CSRL-A13GR	CSRL145921	1400/500	590-2100	1200	2A	800/1100/30	111	321	532	

- This attachment is used for loading, unloading or stacking tobacco boxes.
- 2 hydraulic function.
- Side shift feature available.
- Optional ;
 - Quick release,
 - Load backrest,
 - Pressure adjustment valve,
 - Special opening ranges,



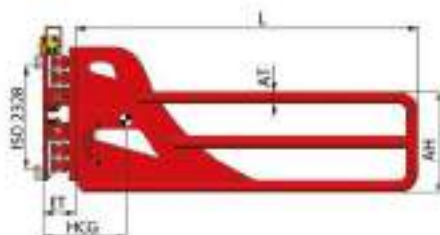
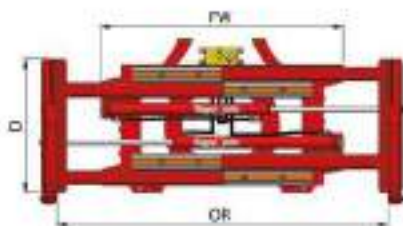

Catalogue Order No	Part No	Capacity (kg/mm)	Opening Range (mm)	Channel Width (mm)	Mounting Class	Arm Dimensions (mm)	Effective Thickness (mm)	Horizontal Centre of Gravity (mm)	Weight (kg)	Price
			OR	CW	ISO2378	A / L / H / T	ET	HCG	W	€
010CTB-B20GZ	CFB702116	1000/590	700-2300	1300	2A/3A	1600/580/460/40	117	392	509	
010CTB-B20GY	CFB702118	1000/590	700-2300	1300	2A/3A	1800/580/460/40	117	416	523	
010CTB-B20GP	CFB702120	1000/590	700-2300	1300	2A/3A	2000/580/460/40	117	424	534	
010CTB-B18GZ	CFB802616	1000/590	800-2600	1300	2A/3A	1600/580/460/40	117	391	511	
010CTB-B18GY	CFB802618	1000/590	800-2600	1300	2A/3A	1800/580/460/40	117	408	526	
010CTB-B18GP	CFB802620	1000/590	800-2600	1300	2A/3A	2000/580/460/40	117	421	538	

- This attachment is used for loading, unloading or stacking rubber foams, sponges.
- 2 hydraulic function.
- Side shift feature available.
- Optional ;
 - Quick release,
 - Load backrest,
 - Pressure adjustment valve,
 - Special opening ranges,
 - Arms of different dimensions.



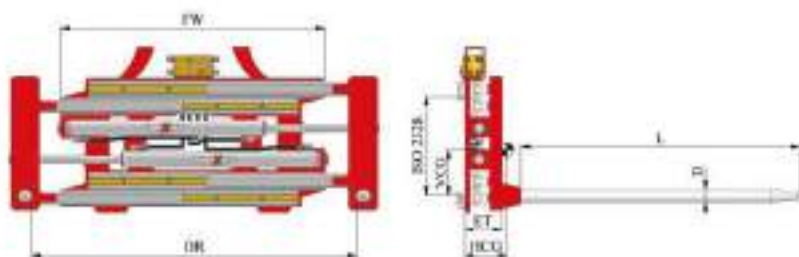

Catalogue Order No	Part No	Capacity (kg/mm)	Opening Range (mm)	Chassis Width (mm)	Mounting Class	Pole Tine Diameter (mm)	Tine Length (mm)	Effective Thickness (mm)	Horizontal Centre of Gravity (mm)	Weight (kg)	Price
			OR	CW	ISO2328	D	L	KT	HCG	W	€
018CTC-A133GJ	CTC103113	1000	310-1334	1000	2A	55	1160	154	191	272	
019CTC-A148GJ	CTC103614	1000	360-1483	1100	2A	55	1160	154	186	284	
014CTC-A158GJ	CTC143115	1400	310-1583	1200	2A	60	1160	159	179	340	
014CTC-A163GJ	CTC143616	1400	360-1633	1200	2A	60	1160	159	175	343	
028CTC-A158GJ	CTC203115	2000	310-1583	1200	2A	70	1160	164	177	368	
028CTC-A168GJ	CTC203616	2000	360-1683	1200	2A	70	1160	164	175	372	
023CTC-B163GJ	CTC233616	2300	360-1633	1200	2A-3A	80	1160	169	182	432	
023CTC-C183GJ	CTC233618	2300	360-1833	1300	2A-3A	80	1160	169	168	446	

- This attachment is used for loading, unloading or stacking horizontally paper rolls.
- 2 hydraulic function.
- Side shift feature available.
- Optional ;
 - Quick release,
 - Load backrest,
 - Pressure adjustment valve,
 - Special opening ranges,



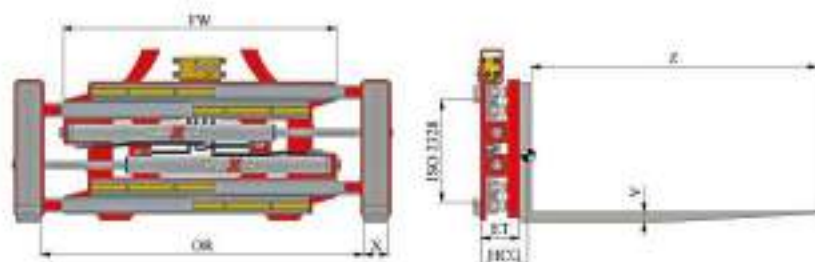

Catalogue Order No	Part No	Capacity (kg/mm)	Opening Range (mm)	Chassis Width (mm)	Mounting Class	Fork Section (mm)	Effective Thickness (mm)	Horizontal Centre of Gravity (mm)	Weight (kg)	Price
			OR	CW	ISO3318	X / Y / Z	ET	HCG	W	€
014CAN-A177GJ	CAN143517	1400/500	150-1770	1200	2A	100x46x1200	154	224	394	
014CAN-A187GJ	CAN144218	1400/500	420-1870	1200	2A	100x46x1200	154	226	398	
023CAN-B197GJ	CAN234219	2300/500	420-1970	1200	2A-3A	125x45x1200	159	289	461	
023CAN-B207GJ	CAN235220	2300/500	520-2070	1300	2A-3A	125x45x1200	159	288	463	
030CAN-C207GJ	CAN305220	3000/600	520-2070	1300	3A-4S	125x56x1200	164	215	478	
030CAN-C217GJ	CAN305221	3000/600	520-2170	1400	3A-4S	125x56x1200	164	193	484	

- 2 hydraulic function.
- Side shift feature available.
- Optional ;
 - Quick release,
 - Load backrest,
 - Pressure adjustment valve,
 - Special opening ranges,
 - Forks of different dimensions.



CFP BALE CLAMPS

Fork Clamps With Manually Turnable Forks

Wagner[®]
attachments

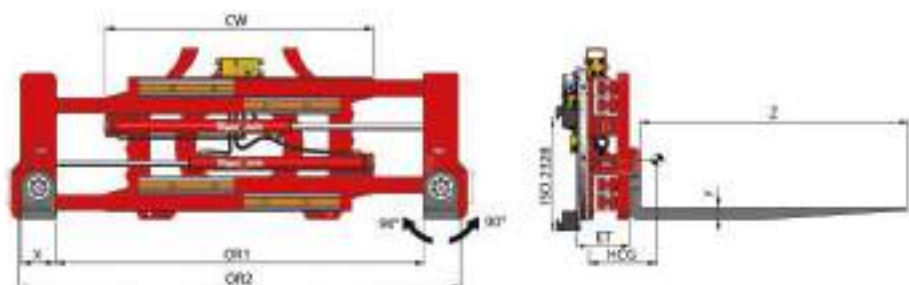

Catalogue Order No	Part No	Capacity on Forks (kg/mm)	Capacity as Clamps (kg/mm)	Opening Range (mm)	Opening Range (mm)	Channel Width (mm)	Mounting Class	Fork Section (mm)	Effective Thickness (mm)	Horizontal Centre of Gravity (mm)	Weight (kg)	Price
				OR-1	OR-2	CW	ISO328	X/Y/Z	ET	HCG	W	€
024CFP-B10GJ	CFP263017	2600/500	1300/300	300-1700	600-2000	1200	2A-3A	150/50/1200	179	219	504	
024CFP-B12GJ	CFP264018	2600/500	1300/300	400-1800	700-2100	1200	2A-3A	150/50/1200	179	228	506	
024CFP-B14GJ	CFP264019	2600/500	1300/300	400-1900	700-2200	1300	2A-3A	150/50/1200	179	219	518	
024CFP-B16GJ	CFP265020	2600/500	1300/300	500-2000	800-2300	1300	2A-3A	150/50/1200	179	217	521	

- Z hydraulic function.
- Side shift feature available.
- Optional :
 - Quick release,
 - Load backrest,
 - Pressure adjustment valve,
 - Special opening ranges,
 - Forks of different dimensions,
 - Slip-on arms for bale.



Wagner[®]

attachments

THINK BIG!

HOLD THE WORLD

White Good Clamps

WGC — White Goods Clamps — 6-1.6-3

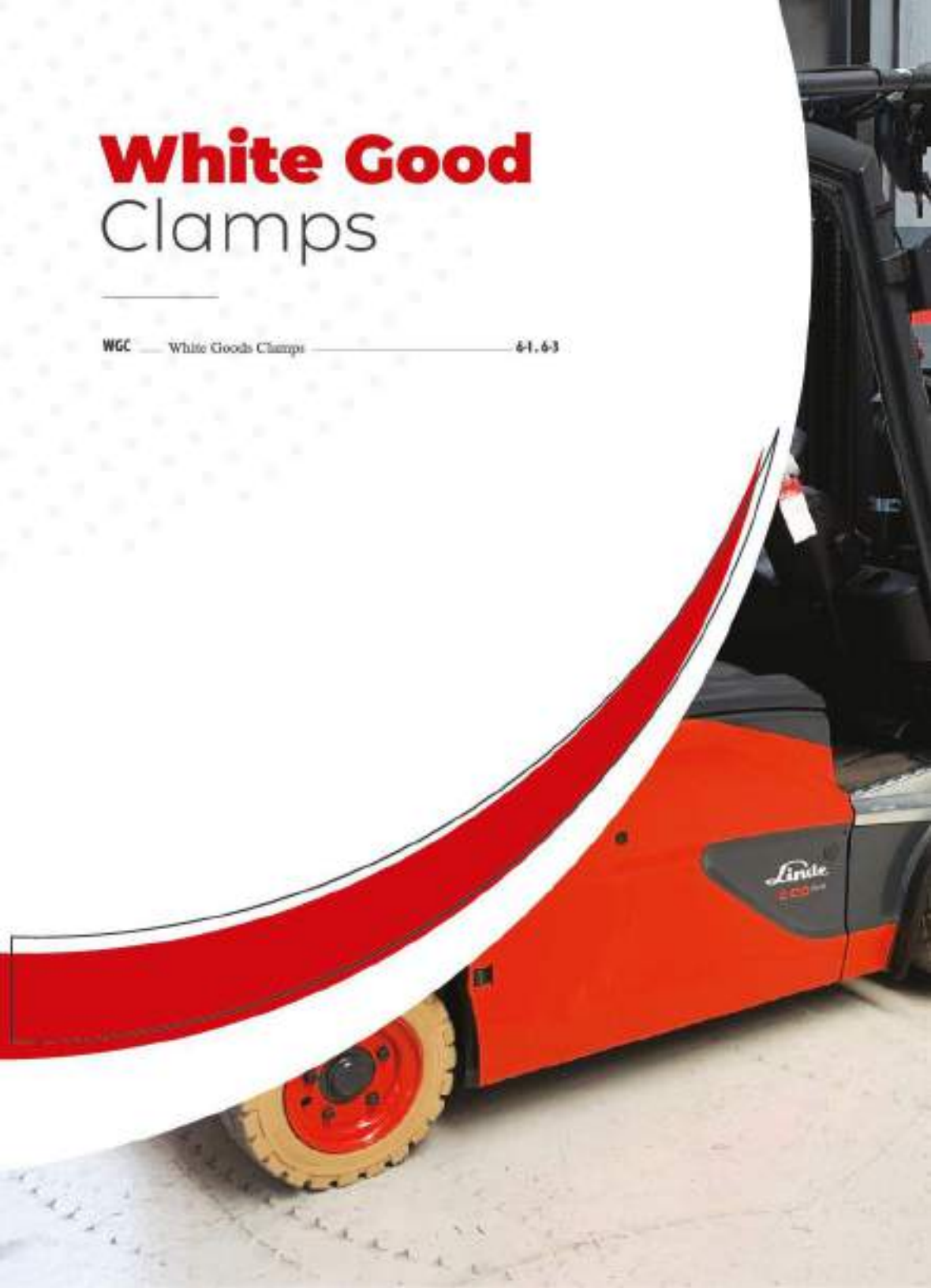





SAMSUNG

REFRIGERATO I

SAMSUNG

REFRIGERATO I

SAMSUNG

REFRIGERATO

White Good
Clamps

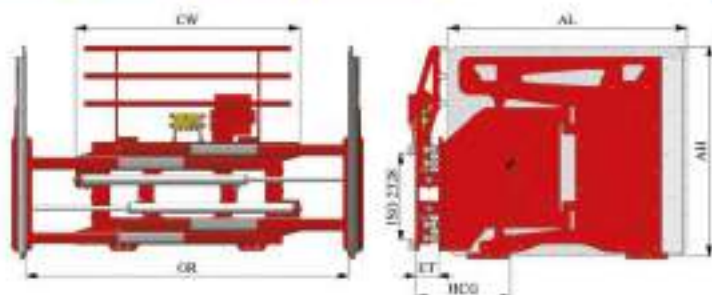

Catalogue Order No	Part No	Capacity	Opening Range (mm)	Chassis Width (mm)	Mounting Class	Arm Height (mm)	Arm length (mm)	Effective Thickness (mm)	Horizontal Centre of Gravity (mm)	Weight (kg)	Price
			GR	CW	ISO 2128	AH	AL	ET	HCG	W	€
009WGC-A02EH	WGC5100102	900/500	500-1980	1200	2A	1000	1000	97	486	585	
009WGC-A02FH	WGC6100102	900/500	600-2180	1300	2A	1000	1000	97	488	587	
009WGC-A07EH	WGC5100107	900/500	500-1980	1200	2A	1000	1070	97	481	598	
009WGC-A07FH	WGC6100107	900/500	600-2180	1300	2A	1000	1070	97	479	601	
009WGC-A17EH	WGC5110117	900/500	500-1980	1200	2A	1100	1170	97	496	647	
009WGC-A17FH	WGC6110117	900/500	600-2180	1300	2A	1100	1170	97	494	649	
009WGC-A20EH	WGC5110120	900/500	500-1980	1200	2A	1100	1200	97	507	662	
009WGC-A20FH	WGC6110120	900/500	600-2180	1300	2A	1100	1200	97	505	665	
010WGC-A22EH	WGC5120122	1000/500	500-1980	1200	2A	1200	1220	101	524	683	
010WGC-A22FH	WGC6120122	1000/500	600-2180	1300	2A	1200	1220	101	521	684	
010WGC-A25EH	WGC5120125	1000/500	500-1980	1200	2A	1200	1250	101	529	689	
010WGC-A25FH	WGC6120125	1000/500	600-2180	1300	2A	1200	1250	101	528	691	
010WGC-A30EH	WGC5120130	1000/500	500-1980	1200	2A	1200	1300	101	538	702	
010WGC-A30FH	WGC6120130	1000/500	600-2180	1300	2A	1200	1300	101	536	704	
010WGC-A32EH	WGC5120132	1000/500	500-1980	1200	2A	1200	1320	101	545	713	
010WGC-A32FH	WGC6120132	1000/500	600-2180	1300	2A	1200	1320	101	541	716	

- This attachment is used for loading, unloading or stacking white goods.
- Standart rubber coated arms.
- 1 hydraulic function.
- Pressure adjustment valve available.
- Optional :
 - Side shift feature,
 - Quick release feature,
 - Arms of different dimensions.

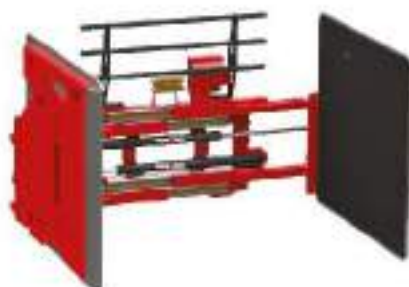

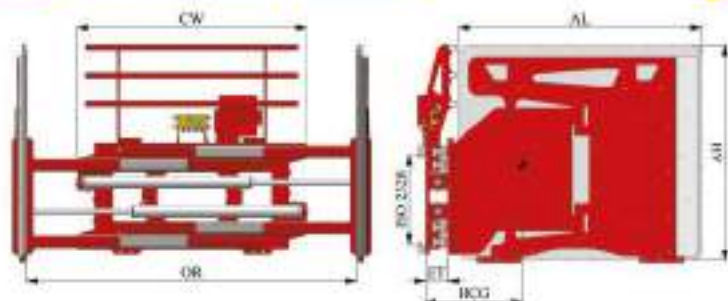

Catalogue Order No	Part No	Capacity	Opening Range (mm)		Chassis Width (mm)	Mounting Class	Arm Height (mm)	Arm Length (mm)	Effective Thickness (mm)	Horizontal Centre of Gravity (mm)	Weight (kg)	Price
			OR	CW								
012WGC-A35EH	WGC5120135	1200/500	580-1980	1280	2A	1200	1350	107	548	726		
012WGC-A35FH	WGC6120135	1200/500	680-2180	1280	2A	1300	1350	107	547	727		
012WGC-A38EH	WGC5120138	1200/500	580-1980	1280	2A	1200	1380	107	558	735		
012WGC-A38FH	WGC6120138	1200/500	680-2180	1280	2A	1300	1380	107	554	737		
012WGC-A40EH	WGC5120140	1200/500	580-1980	1280	2A	1200	1400	107	561	743		
012WGC-A40FH	WGC6120140	1200/500	680-2180	1280	2A	1300	1400	107	559	745		
012WGC-A43EH	WGC5120143	1200/500	580-2080	1380	2A	1200	1430	107	572	786		
012WGC-A43FH	WGC6120143	1200/500	680-2280	1380	2A	1300	1430	107	571	788		

- This attachment is used for loading, unloading or stacking white goods.
- Standard rubber coated arms.
- 1 hydraulic function.
- Pressure adjustment valve available.
- Optional :
 - Side shift feature,
 - Quick release feature,
 - Arms of different dimensions.



WGC WHITE GOOD CLAMPS

White Good Clamps

Wagger[®]
attachments

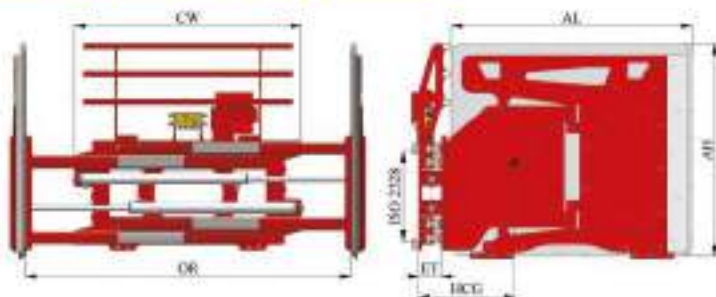

Catalogue Order No	Part No	Capacity	Opening Range (mm)	Chassis Width (mm)	Mounting Class	Arm Height (mm)	Arm Length (mm)	Effective Thickness (mm)	Horizontal Centre of Gravity (mm)	Weight (kg)	Price
			OR	CW	ISO2328	AH	AL	ET	HCG	W	€
013WGC-B40EH	WGC5140140	1300/500	500-2080	1300	2A-3A	1400	1400	121	603	1025	
013WGC-B40FH	WGC6140140	1300/500	600-2280	1300	2A-3A	1400	1400	121	601	1028	
013WGC-B45EH	WGC5145145	1300/500	500-2080	1300	2A-3A	1450	1450	121	614	1067	
013WGC-B45FH	WGC6145145	1300/500	600-2280	1300	2A-3A	1450	1450	121	612	1068	
013WGC-B50EH	WGC5150150	1300/500	500-2080	1300	2A-3A	1500	1500	121	628	1095	
013WGC-B50FH	WGC6150150	1300/500	600-2280	1300	2A-3A	1500	1500	121	627	1097	
013WGC-B60EH	WGC5150160	1300/500	500-2280	1550	2A-3A	1500	1600	125	618	1169	
013WGC-B60FH	WGC6150160	1300/500	600-2380	1550	2A-3A	1500	1600	125	615	1174	

- This attachment is used for loading, unloading or stacking white goods.
- Standard rubber coated arms.
- 1 hydraulic function.
- Pressure adjustment valve available.
- Optional :
 - Side shift feature,
 - Quick release feature,
 - Arms of different dimensions.





Wagger[®]

attachments

THINK BIG!
HOLD THE WORLD

Multi Pallet Handlers

MPH — Multi Pallet Handlers — 71







Multi Pallet
Handlers

MPH MULTI PALLET HANDLERS

Multi Pallet Handlers

Wagner
attachments

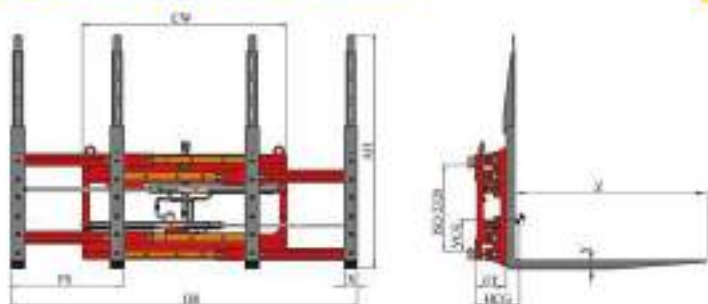

Catalogue Order No	Part No	Capacity (kg/ton)	Opening Range (mm)	Chassis Width (mm)	Fork Section (mm)	Load Centre Height (mm)	Fork Spread (mm)	Fork Section (mm)	Effective Thickness (mm)	Horizontal Centre of Gravity (mm)	Weight (kg)	Price
												€
			OR	CW	ISO208	AH	PS	N/Y/Z	ET	HCG	W	€
026MPH-A43GF	MPH265719	2600/500	570-1930	1220	2A-3A	1200	565-695	8040/1150	170	234	515	
026MPH-A44GF	MPH266220	2600/500	620-2030	1220	2A-3A	1200	565-695	8040/1150	170	233	517	
028MPH-B43GJ	MPH285719	2800/500	570-1930	1220	3A	1200	565-695	8050/1150	190	245	562	
028MPH-B44GJ	MPH286220	2800/500	620-2030	1220	3A	1200	565-695	8050/1150	180	247	564	
032MPH-B43GJ	MPH325719	3200/500	570-1930	1220	3A	1200	565-695	8060/1150	190	256	611	
032MPH-B44GJ	MPH326220	3200/500	620-2030	1220	3A	1200	565-695	8060/1150	190	253	614	

- With the multi pallet handler the fork opening ranges can be adjusted hydraulically, so that alternatively 1 or 2 and 2 or 4 pallets can be picked up.
- 1 hydraulic function.
- Side shift feature optional.





Wagner[®]

attachments

THINK BIG!

HOLD THE WORLD

Push and Push Pull Attachments

SCU	Load Push Attachments	0-1
SCK	Load Push-Pull Attachments	0-2
SPK	360° Rotating Load Push Attachments	0-3





Wagner **X**series

| 8



Push and Push
Pull Attachments

SCU PUSH AND PUSH-PULL ATTACHMENTS

Load Push Attachments

Wagner
attachments

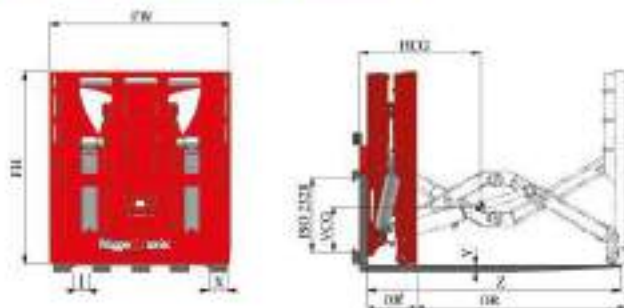

Catalogue Order No	Part No	Capacity (kg/mm)	Opening Range (mm)	Chassis Width (mm)	Mounting Class	Push Plate (mm)	In-to-In (mm)	Fork Section (mm)	Forks Quantity	Horizontal Centre of Gravity (mm)	Weight (kg)	Price
			OK OH	CW	ISO228	FH-FW	I	N/Y/Q		HCG	W	€
02sSCU-B10EH	SCU263114	2600/500	315-1340	1000	3A	1066-1000	140	80/50/1400	5	263	736	
02sSCU-C11FH	SCU323114	3200/500	315-1340	1100	3A-4A	1066-1100	125	80/50/1400	6	257	851	

- This attachment used to push unit loads without pallets or slip sheets into containers or trailers.
- 1 hydraulic function.
- Forks are included.



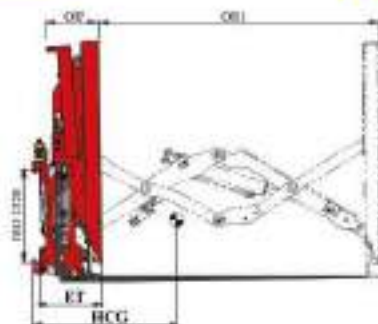
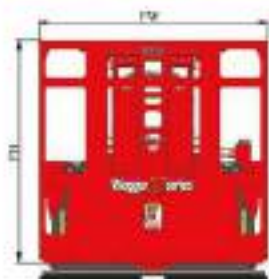

Catalogue Order No	Part No	Capacity (kg/ton)	Opening Range (mm)	Chassis Width (mm)	Mounting Class	Push Plate (mm)	Horizontal Centre of Gravity (mm)	Weight (kg)	Price
			OR - ORL	CW	SHO23A	FI-FW	HCG	W	€
016SCK-A1510	SCK163115	1600/500	350-1160	610	2A	970-1015	334	526	
020SCK-B1510	SCK203115	2000/500	350-1160	610	3A	970-1015	342	548	

- They enable transportation of loads with inexpensive and place saving slip sheets which are usually made of plastic or cardboard.
- 1 hydraulic function.
- No sheet retainer.



SPK PUSH AND PUSH-PULL ATTACHMENTS

360° Rotating Load Push Attachments

Wagger®
attachments

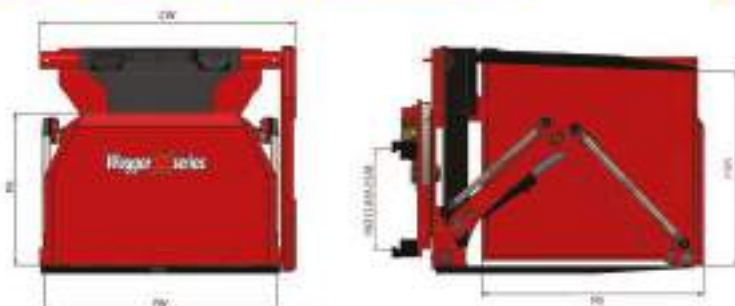

Catalogue Order No	Part No	Capacity (kg/mm)	Opening Range (mm)	Fork Opening Range (mm)	Chassis Width (mm)	Mounting Class	Push Piston (mm)	Horizontal Centre of Gravity (mm)	Weight (kg)	Price
			OR1-OR	FOR	CW	ISO2328	PI-8W	HCC	W	€
823SPK-B1550	SPK231550	2680/500	260-1100	780-1280	1250	3A	768-1220	593	1446	

- This attachment are put into operation when loads have to be transferred from a production pallet to a cheaper transport pallet (one way pallet) or directly loaded into containers, onto lorries, etc.
- This attachment, has continuous 360° rotation in both directions.
- 2 hydraulic function.





Wagner[®]

attachments

THINK BIG!

HOLD THE WORLD

Brick-Block and Keystone Clamps

BFP	Brick - Block Clamps With Forks	9-1
BSP	Brick - Block Clamps With Forks / Large Pads	9-2
BAP	Brick - Block Clamps With Pistons	9-3
DGA	Two Sided Keystone Clamps	9-4
SGA	Four Sided Keystone Clamps	9-5

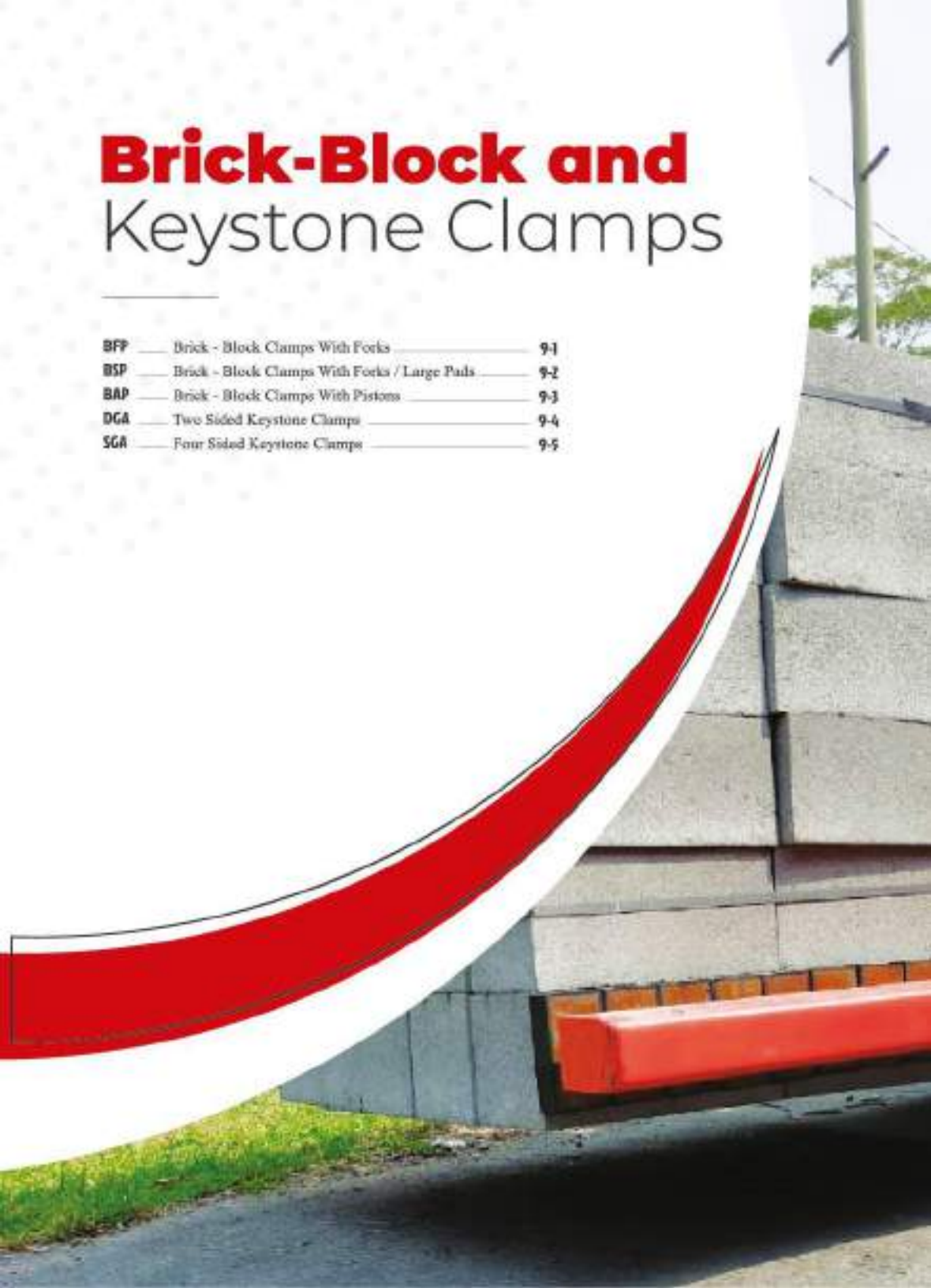



Waggoner **X**series

Wagger X series



Brick-Block and
Keystone Clamps

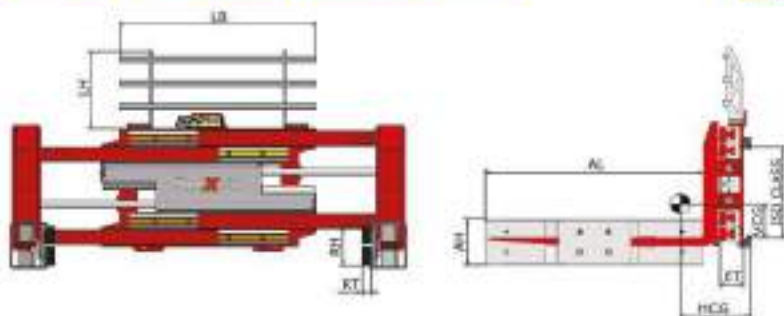

Catalogue Order No	Part No	Capacity (kg/tons)	Opening Range (mm)	Chassis Width	Mounting Class	Arm Height (mm)	Arm Weight (mm)	Arm Length (mm)	Effective Thickness (mm)	Horizontal Centre of Gravity (mm)	Weight (kg)	Price
			OR	CW	ISO2128	AH	AW	AL	ET	HCG	W	€
0168FP-A17GF	BFP164017	1600/500	400-1700	1200	2A	135	245	1250	152	362	450	
0208FP-B17GF	BFP204017	2000/500	400-1700	1200	2A-3A	135	245	1250	155	340	510	

- This attachment is used for loading, unloading or stacking brick.
- Forked type's other function :
When you take out the coupling arms from the forks, you can use it for pallet loading.
- 2 hydraulic function.
- Standart rubber coated arms.
- Side shift feature available.
- Pressure adjustment valve optional.



BSP BRICK - BLOCK AND KEYSTONE CLAMPS

Brick - Block Clamps With Forks / Large Pads

Wagner®
attachmenT

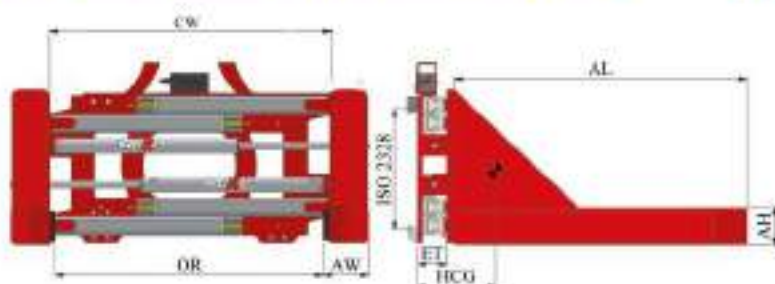

Catalogue Order No	Part No	Capacity (kg/m ³)	Opening Range (mm)	Chassis Width (mm)	Mounting Class	Arm Height (mm)	Arm Width (mm)	Arm Length (mm)	Effective Thickness (mm)	Horizontal Centre of Gravity (mm)	Weight (kg)	Price
			OE	CW	ISO2328	AH	AW	AL	ET	HCG	W	€
010BSP-A17GS	BSP169017	1600/500	400-1700	1200	2A	128	210	1100	152	148	483	
020BSP-B17GS	BSP209017	2000/500	400-1700	1200	3A	128	210	1100	157	143	518	
026BSP-B17GS	BSP269017	2600/500	400-1700	1200	3A	242	220	1400	157	134	542	

- This attachment is used for loading, unloading or stacking brick.
- 2 hydraulic function.
- Standard rubber coated arms.
- Side shift feature available.
- Pressure adjustment valve optional.



BAP BRICK - BLOCK AND KEYSTONE CLAMPS

Brick - Block Clamps With Pistons

Wagger
attachments

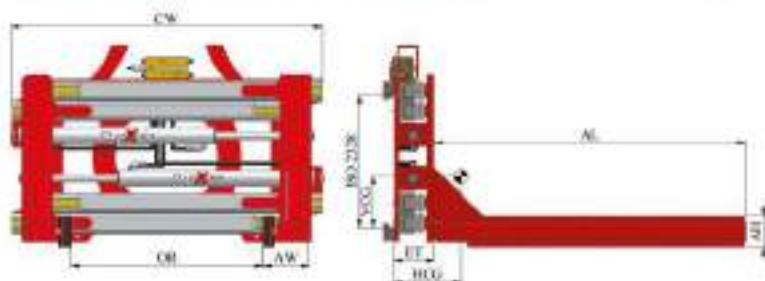

Catalogue Order No	Part No	Capacity (kg/psn)	Opening Range (mm)	Chassis Width (mm)	Mounting Class	Arm Height (mm)	Arm Width (mm)	Arm Length (mm)	Effective Thickness (mm)	Horizontal Centre of Gravity (mm)	Weight (kg)	Price
			OH	CW	ISO128	AH	AW	AL	ET	HCG	W	€
014BAP-A17GA	BAP144017	1600/500	480-1700	1200	2A	120	190	1250	152	380	430	
020BAP-B17GA	BAP204017	2000/500	480-1700	1200	2A-5A	120	190	1250	152	328	480	

- This attachment is used for loading, unloading or stacking brick.
- 2 hydraulic function.
- Standart rubber coated arms.
- Side shift feature available.
- Pressure adjustment valve optional.



DGA BRICK - BLOCK AND KEYSTONE CLAMPS

Two Sided Keystone Clamps

Wagner
 attachment

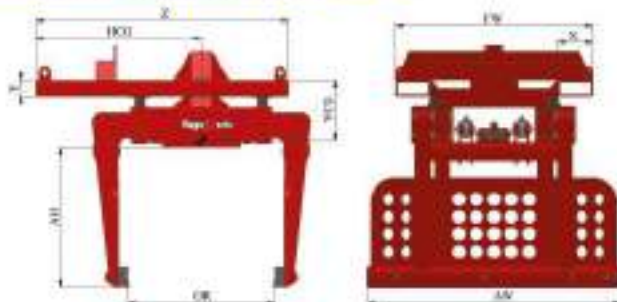

Catalogue Order No	Part No	Capacity (kg/mm)	Opening Range (mm)	Chassis Width (mm)	Fork Section (mm)	Arm Height (mm)	Arm Width (mm)	Horizontal Centre of Gravity (mm)	Weight (kg)	Price
			CHL	FW	X/Y/Z	AH	AW	HCG	W	€
01SDGA-X0800	DGA150720	1500/500	500-1400	1048	160/60/1300	720	1300	790	700	
018DGA-X1000	DGA180880	1800/500	500-1400	1048	160/60/1300	880	1300	788	790	
021DGA-X1200	DGA211040	2100/500	500-1400	1048	160/60/1300	1040	1300	785	880	

- This attachment, is used for by two sided to move products such as keystone, borders, brick and tiles.
- 1 hydraulic function.



SGA BRICK - BLOCK AND KEYSTONE CLAMPS

Four Sided Keystone Clamps

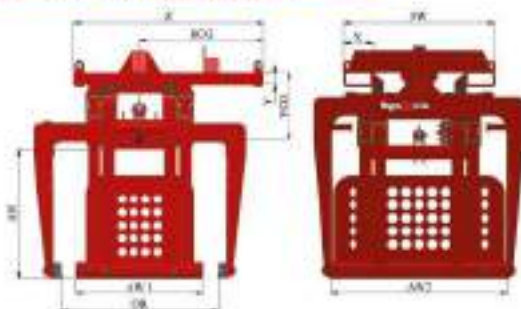

Catalogue Order No	Part No	Capacity (kg/mm)	Opening Range (mm)	Chassis Width (mm)	Fork Section (mm)	Arm Height (mm)	Arm Width (mm)	Horizontal Centre of Gravity (mm)	Weight (kg)	Price
			ØB	ØW	X/Y/Z	AB	AW	BCG	W	€
019SGA-X1800	SGA150720	1500/500	918-1310 1000-1400	1080	160/90/1300	720	870-1200	802	952	
019SGA-X1000	SGA180690	1000/500	918-1200 1000-1400	1040	160/90/1300	890	870-1200	793	1044	
021SGA-X1200	SGA211040	2100/500	918-1200 1000-1400	1040	160/90/1300	1040	870-1200	781	1131	

- This attachment, is used for by four sided to move products such as keystone, borders, brick and tiles.
- 1 hydraulic function.





Wagner[®]
attachments

Wagger[®]

attachments

THINK BIG!

HOLD THE WORLD

Buckets

Attachments

LMB	Hydraulic Buckets	10-1
LNF	Hydraulic Buckets On Forks	10-2
	Density Table of Some Product	10-3







Bucket
Attachments

LMB BUCKETS

Hydraulic Buckets

Wagner®
attachmores

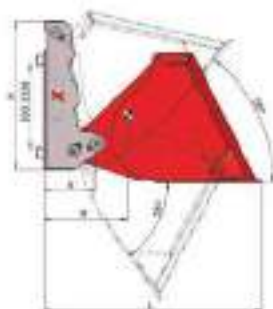
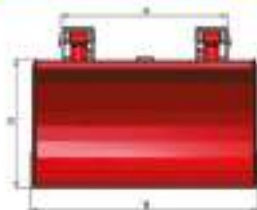

Catalogue Order No	Part No	Stack Capacity (m³)	Heaped Capacity (m³)	Capacity (kg)	Mounting Class	Back Chassis Width (mm)	Front Bucket Width (mm)	Height (mm)	Chassis Height (mm)	Effective Thickness (mm)	Length (mm)	Center Of Gravity (mm)	Weight (kg)	Price
						CW	W	H	FH	E1	L	COG	W	€
050LMB-A1350	LMB050135A	0,5	0,6	1100	2A	986	1350	765	880	315	1295	500	495	
050LMB-B1350	LMB050135B	0,5	0,6	1100	3A	986	1350	765	880	315	1295	500	495	
070LMB-A1500	LMB070150A	0,7	0,8	1540	2A	986	1500	850	880	315	1415	500	555	
070LMB-B1500	LMB070150B	0,7	0,8	1540	3A	986	1500	850	880	315	1415	500	555	
100LMB-A1700	LMB100170A	1,0	1,1	2200	2A	986	1700	960	880	315	1555	600	605	
100LMB-B1700	LMB100170B	1,0	1,1	2200	3A	986	1700	960	880	315	1555	600	605	
120LMB-B2060	LMB120206B	1,2	1,4	2640	3A	986	2060	960	880	315	1555	600	830	
120LMB-C2060	LMB120206C	1,2	1,4	2640	4A	986	2060	960	880	315	1555	600	830	
150LMB-B2100	LMB150210B	1,5	2,1	3300	3A	986	2100	1030	880	315	1655	670	940	
150LMB-C2100	LMB150210C	1,5	2,1	3300	4A	986	2100	1030	880	315	1655	670	940	
200LMB-B2300	LMB200230B	2,0	2,5	4400	3A	986	2300	1125	880	315	1785	770	1050	
200LMB-C2300	LMB200230C	2,0	2,5	4400	4A	986	2300	1125	880	315	1785	770	1050	

- This attachment, is used for loading coal, droppings, clay, sand, broken stone, seed, etc.
- 1 hydraulic function.
- Hook-on type (2A – 3A)



LMF BUCKETS

Hydraulic Buckets On Forks

Wagner®
attachments

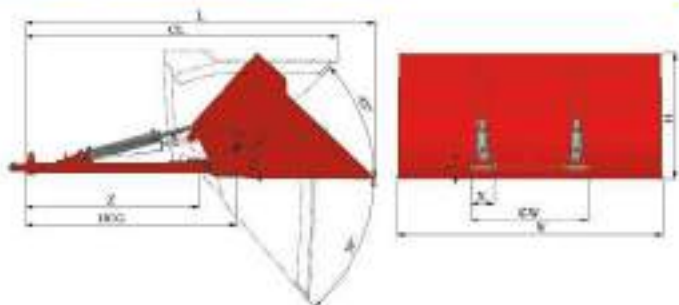

Catalogue Order No	Part No	Struck Capacity (m³)	Heaped Capacity (m³)	Capacity (kg)	Bucket Width (mm)	Chassis Width (mm)	Bucket Height (mm)	Length in Upright Position (mm)	Length (mm)	Fork Section (mm)	Horizontal Centre of Gravity (mm)	Weight (kg)	Price
					W	CB	H	CL	L	X / Y / Z	HCG	W	€
050LMF-X1900	LMF059100	0,5	0,6	1100	1000	810	800	2050	2430	150/70/1200	1306	395	
060LMF-X1200	LMF069120	0,6	0,7	1320	1200	810	800	2050	2430	150/70/1200	1412	421	
070LMF-X1300	LMF079130	0,7	0,8	1540	1300	810	800	2050	2430	150/70/1200	1428	434	
080LMF-X1500	LMF089150	0,8	0,9	1710	1500	810	800	2050	2430	150/70/1200	1447	462	
090LMF-X1850	LMF099185	0,9	1,1	1980	1850	810	800	2050	2430	150/70/1200	1476	511	

- This attachment, is used for loading coal, droppings, clay, sand, broken stone, seed, etc.
- 1 hydraulic function.
- On fork type.



DENSITY TABLE OF SOME PRODUCTS

Cement (Powder)	1,75 - 1,95 t/m ³
Fertilizer	1,10 - 1,30 t/m ³
Aluminum (Casting - Forging)	2,55 - 2,80 t/m ³
Brass (Cast - Rolled)	8,40 - 8,70 t/m ³
Lead Ore, Galena	7,30 - 7,60 t/m ³
Gravel	2,76 t/m ³
Tire	1,5 gr/cm ³
Pine	2,4 - 2,8 gr/cm ³
Coal	0,7 - 0,9 gr/cm ³
Paper	0,93 gr/cm ³
Soil	1,2 - 1,5 gr/cm ³
Limestone	1,2 - 1,6 gr/cm ³
Oat	0,45 - 0,55 t/m ³
Potato	0,65 - 0,75 t/m ³
Wheat	0,70 - 0,80 t/m ³
Sand (Wet)	1,90 - 2,10 t/m ³
Sand (Dry)	1,40 - 1,65 t/m ³
Concrete	2,10 - 2,20 t/m ³

- The values given may vary according to different situations.



Wagger
THINK BIG!
HOLD THE WORLD

THINK BIG!



Wagger
green factory



Wagner[®]

attachments

THINK BIG!

HOLD THE WORLD

Mechanical Attachments

AX	Crane Hooks	11-1
AH	Jim Boom On Forks	11-2
AT	Telescopic Jim Boom On Forks	11-3
DMS	Metal Drum Attachments	11-4
DPS	Plastic Drum Attachments	11-5
DRS	Plastic Drum Attachments	11-6
WPI	Working Platform	11-7
BK	Dumping Bucket	11-8
KX	Snow Plough	11-9
CK	Fork Extension	11-10, 11-12
CZ	Load Balancing Forks	11-13
CZ-R	Load Balancing Forks, Hook-On Type	11-14
CC	Carpet Carrying Rams	11-15, 11-22
FT	Heavy Material Carrying Rams	11-23





MAX. CAPACITY

400 kg

CE

Wagner

Mechanical
Attachments



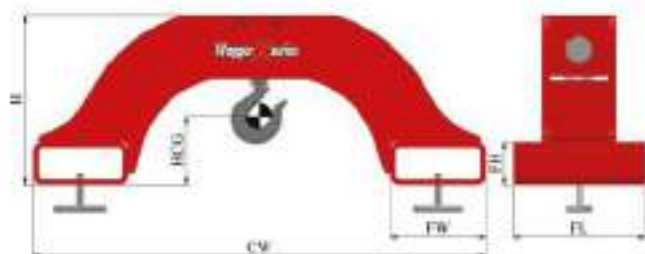

Catalogue Order No	Part No	Capacity (kg/mm)	Fork Section (mm)	Fork Section (mm)	Height (mm)	Width (mm)	Horizontal Centre of Gravity (mm)	Weight (kg)	Price
			C	FW / FH / FL	H	W	HCG	W	€
025AX	AX062500	2500	680	160/60/250	320	800	125	47	
040AX	AX064000	4000	680	160/60/250	320	800	125	54	

- Provides a quick and economical method of the lifting and positioning of un palletised loads.
- Its position along the forks can be easily adjusted.



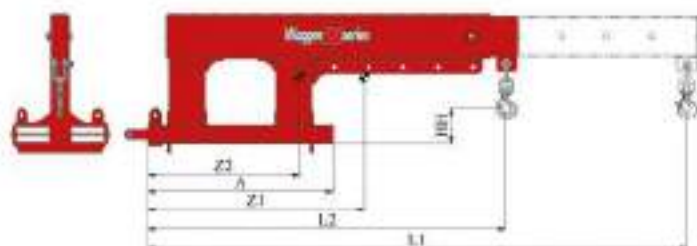

Catalogue Order No	Part No	Load Capacity (kg)	Load Centre (mm)	Hook Height (mm)	Fork Case Length (mm)	Extended Centre of Gravity (mm)	Closed centre of Gravity (mm)	Extended Hook Distance (mm)	Closed Hook Distance (mm)	Weight (kg)	Price
Q	L.C.	III	L	Z1	Z2	L1	L2	W	€		
020AH	A18003000	2000	600	384	900	893	630	3073	1755	230	
030AH	A18003000	3000	600	384	900	900	641	3073	1755	220	
040AH	A18004000	4000	600	384	900	910	649	3073	1755	233	
050AH	A18005000	5000	600	384	900	921	660	3073	1755	250	
060AH	A18006000	6000	600	384	900	933	673	3073	1755	260	

Product	Hook Position	Hook Distance (mm)											
		1	2	3	4	5	6	7	8	9	10	11	12
020AH	Capacity (kg)	830	1000	1170	1340	1510	1805	2025	2245	2465	2685	2905	3075
	Capacity (kg)	1445	1700	2025	2340	2655	2955	3300	3550	4085	4450	4815	5000
	Capacity (kg)	2165	1800	1535	1340	1190	995	890	800	750	670	620	585
	Capacity (kg)	2890	2400	2050	1790	1590	1330	1185	1070	975	894	825	780
	Capacity (kg)	3615	3000	2565	2240	1990	1690	1335	1235	1215	115	1030	975
050AH	Capacity (kg)	4335	3600	3075	2685	2380	1990	1775	1600	1490	1340	1225	1170

- This attachment makes it possible to lift loads beyond the tips of the forks.



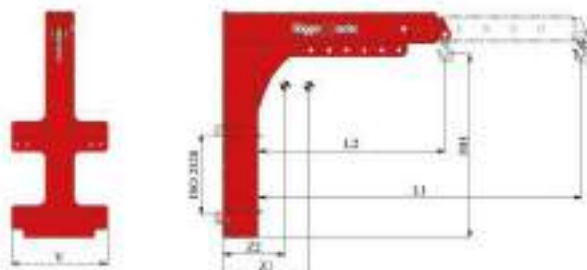

Catalogue Order No	Part No	Load Capacity (kg)	Load Centre (mm)	Hook Height (mm)	Mounting Class	Body Width (mm)	Extended Centre of Gravity (mm)	Closed Centre of Gravity (mm)	Extended Hook Distance (mm)	Closed Hook Distance (mm)	Weight (kg)	Price
		Q	L.C	H	END228	V	Z1	Z2	L1	L2	W	€
815AT-A1060	AT001500	1500	400	1000	2A	208	490	368	2215	1375	260	
825AT-A1060	AT002500	2500	400	1000	2A	208	530	376	2215	1375	300	
830AT-B1060	AT003000	3000	400	1000	3A	208	535	378	2215	1375	400	
840AT-B1060	AT004000	4000	400	1000	3A	208	536	381	2215	1375	430	
850AT-C1060	AT005000	5000	400	1000	4A	208	547	384	2215	1375	460	

Product	Hook Position	Hook Distance (mm)					
		1	2	3	4	5	6
Product	815AT	450	590	520	475	435	485
	825AT	1085	995	870	790	725	670
	830AT	1300	1160	1045	950	870	810
	840AT	1725	1545	1390	1265	1160	1080
	850AT	2170	1925	1740	1585	1455	1320
		Capacity (kg)					



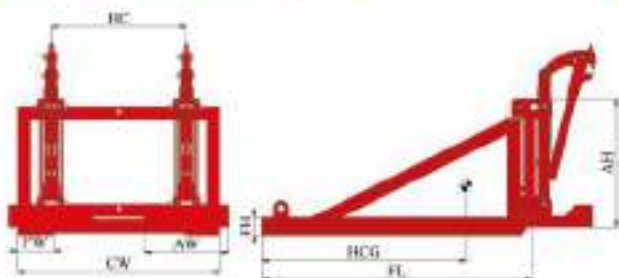

Catalogue Order No	Part No	Drum Quantity	Capacity (kg/mm)	Chassis Width (mm)	Fork Section (mm)	Arm Height (mm)	Arm Width (mm)	Hook Carriage (mm)	Horizontal Centre of Gravity (mm)	Weight (kg)	Price
				CW	FW / FH / FL	AH	AW	BC	HCG	W	€
001DMS-S150	DMS0150	Single	150	600	175/75/1150	870	380	-	851	105	
007DMS-1700	DMS0700	Double	700	600	175/75/1150	870	380	600	945	112	

- This attachment is for use stacking, picking and racking of steel drums without the need for pallets.



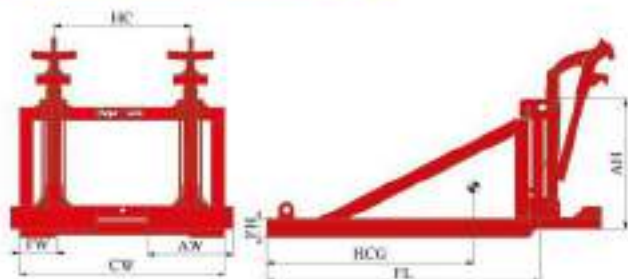

Catalogue Order No	Part No	Drum Quantity	Capacity (kg/m ³)	Chassis Width (mm)	Fork Section (mm)	Arm Height (mm)	Arm Width (mm)	Hook Centre (mm)	Horizontal Centre of Gravity (mm)	Weight (kg)	Price
				CW	FW / FL / FL	AH	AW	HC	HCG	W	+
000DPS-S150	DPS0350	Single	350	600	175/75/1150	570	380	-	853	104	
000DPS-D700	DPS0700	Double	700	900	175/75/1150	570	380	600	945	135	

- This attachment is for use stacking, picking and racking of plastic drums without the need for pallets.



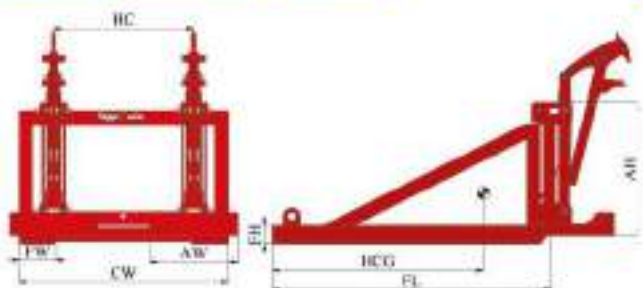

Catalogue Order No	Part No	Drum Quantity	Capacity (kg/m)	Chassis Width (mm)	Fork Section (mm)	Arm Height (mm)	Arm Width (mm)	Hook Centre (mm)	Horizontal Centre of Gravity (mm)	Weight (kg)	Price
				CW	FW / FH / FL	AH	AW	HC	HCG	W	€
001DRS-S150	DRS0350	Single	250	800	175/75/1150	570	380	-	353	103	
007DRS-D100	DRS0700	Double	700	800	175/75/1150	570	380	600	945	132	

- This attachment is for use stacking, packing and racking of plastic drums without the need for pallets.



WP1 MECHANICAL ATTACHMENTS

Working Platform

Wagner®
attachments

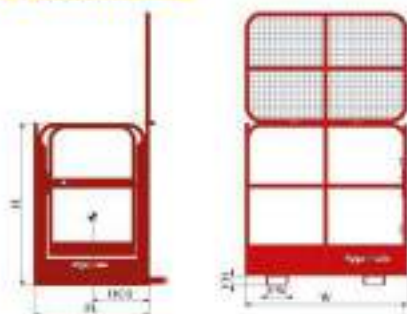

Catalogue Order No.	Part No.	Capacity (kg/mm)	Fork Center (mm)	Fork Section	Height (mm)	Width (mm)	Length (mm)	Horizontal Centre of Gravity	Weight (kg)	Price
		CW	FW / FL / CL	H	W	L	BCK	W	€	
002WP1	WP1X0200	200	715	135/60/850	1120	1200	850	425	152	

- This attachment suited for installation work carried out in elevated positions.
- When working on working platforms, local Accident Prevention Regulations must be observed.
- This attachment ;
 - Has four sided plates to prevent tool or component loss.
 - Has fork locking pins for safe attachment to truck.
 - Has self - closing door.
 - Fully tested with certificate.





Catalogue Order No	Part No	Capacity (kg/m ³)	Chassis Width (mm)	Fork Section	Bucket Height (mm)	Bucket Width (mm)	Bucket Length (mm)	Height (mm)	Horizontal Centre of Gravity (mm)	Weight (kg)	Price
			CW	FW / FH / FL	BH	BW	BL	H	HCG	W	€
005BK-X0900	BK050800	0,5m ³	620	140/90/1260	770	800	1270	955	530	215	
008BK-X1000	BK081000	0,8m ³	620	140/90/1260	850	1000	1345	1032	570	264	
010BK-X1150	BK101150	1,0m ³	1000	140/90/1260	960	1150	1532	1156	648	347	
015BK-X1300	BK151300	1,5m ³	1000	140/90/1260	1066	1300	1697	1242	717	483	

- Attach it to your forklift forks and dump the waste easily thanks to the automatic tipping system.



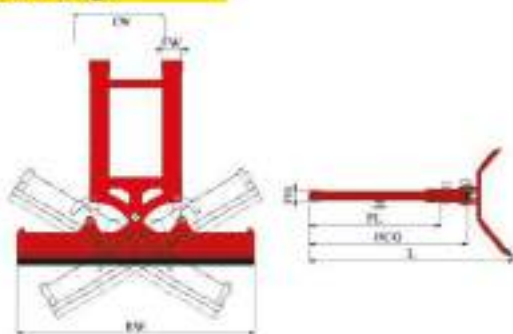

Catalogue Order No	Part No	Chassis Width (mm)	Fork Section (mm)	Bucket Height (mm)	Bucket Width (mm)	Length (mm)	Horizontal Centre of Gravity (mm)	Weight (kg)	Price
		CW	FW / FH / FL	BH	BW	L	HCG	W	C
018KK-X1800	KK1800	695	135/55/1090	825	1800	1554	1162	298	

- Snow plough are used for removing snow from large areas and paths.
- They are mounted by means of fork pockets that are secured with clamping screws.
- Due to the swiveling angle to the right or to the left the snow will slide to the side.



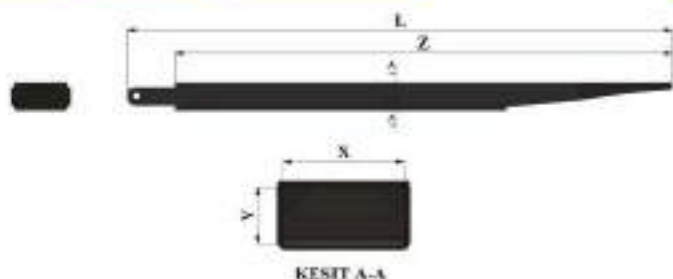

Catalogue Order No	Part No	Load Capacity of Lift Truck	Fork Cross Section (mm)	External Dimensions (mm)	Length (mm)	Weight (kg)	Price
		kg/mm	A / B / C	X / Y	Z	W	€
018CK-200116	CK080516	1800	80/35/C	105/60	1600	58	
018CK-200118	CK080518	1800	80/35/C	105/60	1800	64	
018CK-200120	CK080520	1800	80/35/C	105/60	2000	71	
020CK-200216	CK0804016	2000	80/40/C	105/60	1600	60	
020CK-200218	CK0804018	2000	80/40/C	105/60	1800	66	
020CK-200220	CK0804020	2000	80/40/C	105/60	2000	73	
020CK-200316	CK1003516	2000	100/35/C	125/60	1600	62	
020CK-200318	CK1003518	2000	100/35/C	125/60	1800	69	
020CK-200320	CK1003520	2000	100/35/C	125/60	2000	77	
025CK-200416	CK1004016	2500	100/40/C	125/65	1600	64	
025CK-200418	CK1004018	2500	100/40/C	125/65	1800	71	
025CK-200420	CK1004020	2500	100/40/C	125/65	2000	79	
025CK-200516	CK1004516	2500	100/45/C	125/70	1600	66	
025CK-200518	CK1004518	2500	100/45/C	125/70	1800	73	
025CK-200520	CK1004520	2500	100/45/C	125/70	2000	81	
030CK-200616	CK1005016	3000	100/50/C	125/75	1600	67	
030CK-200618	CK1005018	3000	100/50/C	125/75	1800	75	
030CK-200620	CK1005020	3000	100/50/C	125/75	2000	84	

- It was made to extend the length of standard forks.
- Fork extensions are easy to use and fast.
- It is used to put the load further away or to get it from a distance.



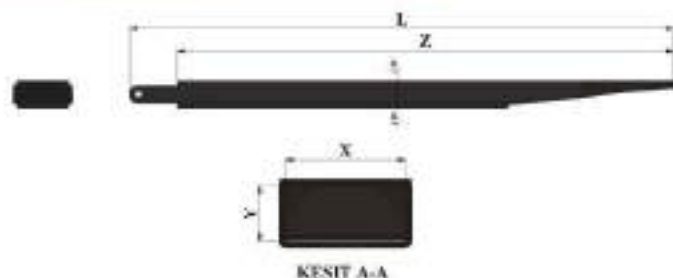

Catalogue Order No	Part No	Load Capacity of Lift Truck	Fork Gross Section (mm)	External Dimensions (mm)	Length (mm)	Weight (kg)	Price
030CK-X0716	CK1204016	3000	120/40C	145/65	1600	66	
030CK-X0718	CK1204018	3000	120/40C	145/65	1800	77	
030CK-X0720	CK1204020	3000	120/40C	145/65	2000	85	
030CK-X0816	CK1204516	3000	120/45C	145/70	1600	71	
030CK-X0818	CK1204518	3000	120/45C	145/70	1800	80	
030CK-X0820	CK1204520	3000	120/45C	145/70	2000	88	
035CK-X0916	CK1205016	3500	120/50C	145/75	1600	75	
035CK-X0918	CK1205018	3500	120/50C	145/75	1800	82	
035CK-X0920	CK1205020	3500	120/50C	145/75	2000	90	
030CK-X1016	CK1254016	3000	125/40C	150/65	1600	70	
030CK-X1018	CK1254018	3000	125/40C	150/65	1800	76	
030CK-X1020	CK1254020	3000	125/40C	150/65	2000	85	
030CK-X1116	CK1254516	3000	125/45C	150/70	1600	72	
030CK-X1118	CK1254518	3000	125/45C	150/70	1800	81	
030CK-X1120	CK1254520	3000	125/45C	150/70	2000	90	
035CK-X1216	CK1255016	3500	125/50C	150/75	1600	74	
035CK-X1218	CK1255018	3500	125/50C	150/75	1800	83	
035CK-X1220	CK1255020	3500	125/50C	150/75	2000	92	

- It was made to extend the length of standard forks.
- Fork extensions are easy to use and fast.
- It is used to put the load further away or to get it from a distance.



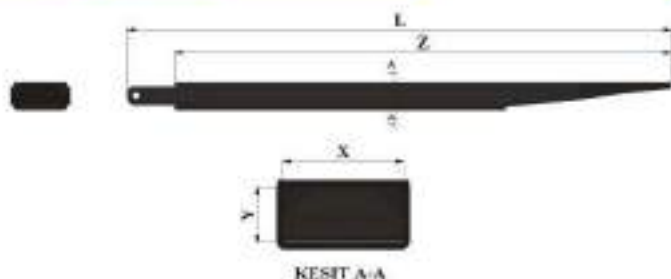

Catalogue Order No	Part No	Load Capacity of Lift Truck	Fork Cross Section (mm)	External Dimensions (mm)	Length (mm)	Weight (kg)	Price
		kg/mm	A / B / C	X / Y	Z	W	€
015CK-X1316	CK1304516	3500	13045/C	155/70	1600	74	
015CK-X1318	CK1304518	3500	13045/C	155/70	1800	83	
015CK-X1320	CK1304520	3500	13045/C	155/70	2000	92	
015CK-X1416	CK1305016	3500	13050/C	155/75	1600	75	
015CK-X1418	CK1305018	3500	13050/C	155/75	1800	85	
015CK-X1420	CK1305020	3500	13050/C	155/75	2000	94	
040CK-X1518	CK1504518	4800	15045/C	175/70	1800	89	
040CK-X1520	CK1504520	4800	15045/C	175/70	2000	98	
040CK-X1522	CK1504522	4800	15045/C	175/70	2200	107	
060CK-X1618	CK1505018	5800	15050/C	175/75	1800	91	
060CK-X1620	CK1505020	5800	15050/C	175/75	2000	100	
060CK-X1622	CK1505022	5800	15050/C	175/75	2200	110	
060CK-X1718	CK1505518	6800	15055/C	175/80	1800	107	
060CK-X1720	CK1505520	6800	15055/C	175/80	2000	119	
060CK-X1722	CK1505522	6800	15055/C	175/80	2200	131	
070CK-X1818	CK1506018	7800	15060/C	175/85	1800	121	
070CK-X1820	CK1506020	7800	15060/C	175/85	2000	135	
070CK-X1822	CK1506022	7800	15060/C	175/85	2200	148	

- It was made to extend the length of standard forks.
- Fork extensions are easy to use and fast.
- It is used to put the load further away or to get it from a distance.





Catalogue Code No	Part No	Capacity (kg/mm)	Load Centre (mm)	Fork Dimension (mm)	Fork Dimension (mm)	Fork Dimension (mm)	Height (mm)	Horizontal Centre of Gravity (mm)	Weight (kg)	Price
		kg/mm	CW	X	Y	Z	H	HCG	W	F
025CZ-X30	CZ253000	2500/500	3000	100	40	1200	500	349	107	
030CZ-X30	CZ303000	3000/500	3000	125	45	1200	500	368	148	
040CZ-X40	CZ404000	4000/600	4000	125	50	1200	500	281	197	
050CZ-X40	CZ504000	5000/600	4000	150	50	1200	500	580	463	

- The load balancing forks has been designed for the occasional handling of particularly long and instable loads such as plastic tubes, sheet metal board etc.



CZ-R MECHANICAL ATTACHMENTS

Load Balancing Forks, Hook-On Type

Wagner®
attachments



Catalogue Order No	Part No	Capacity (kg/min)	Mounting Class	Chassis Width (mm)	Fork Dimension (mm)	Fork Dimension (mm)	Fork Dimension (mm)	Height (mm)	Horizontal Centre of Gravity (mm)	Weight (kg)	Price
				1902328 CW	X	Y	Z	H	HCG	W	€
025CZR-A30	CZR253000	2500/500	2A	3000	100	40	1200	500	286	422	
030CZR-B30	CZR303000	3000/500	3A	3000	125	45	1200	500	304	486	
040CZR-C40	CZR404000	4000/500	4A	4000	125	50	1200	500	245	542	
050CZR-C40	CZR504000	5000/500	4A	4000	150	50	1200	500	518	588	

- The load balancing forks has been designed for the occasional handling of particularly long and instable loads such as plastic tubes, sheet metal board etc.



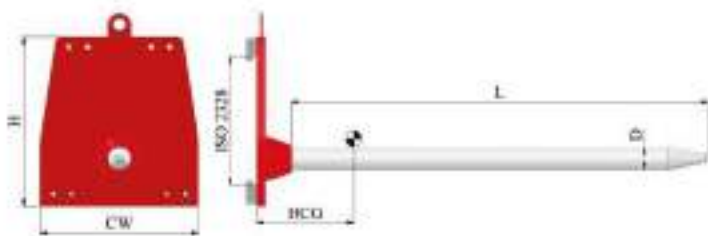

Catalogue Order No	Part No	Capacity (kg/min)	Chassis Width (mm)	Mounting Class	Boom Diameter (mm)	Boom Length (mm)	Height (mm)	Horizontal Centre of Gravity (mm)	Weight (kg)	Price
			CW	ISO 2328	D	L	H	HCC	W	€
013CC-065A1250	CC0651250	1354	410	2A	65	1250	505	254	106	
011CC-065A1500	CC0651500	1152	410	2A	65	1500	505	325	112	
008CC-065A2000	CC0652000	849	410	2A	65	2000	505	485	125	
006CC-065A2500	CC0652500	679	410	2A	65	2500	505	661	138	
005CC-065A3000	CC0653000	566	410	2A	65	3000	505	850	151	
004CC-065A3500	CC0653500	485	410	2A	65	3500	505	1049	164	
004CC-065A4000	CC0654000	424	410	2A	65	4000	505	1255	177	
003CC-065A5000	CC0655000	340	410	2A	65	5000	505	1685	203	
017CC-070A1250	CC0701250	1702	410	2A	70	1250	505	278	113	
014CC-070A1500	CC0701500	1418	410	2A	70	1500	505	357	119	
010CC-070A2000	CC0702000	1063	410	2A	70	2000	505	527	134	
008CC-070A2500	CC0702500	851	410	2A	70	2500	505	713	149	

- Carpet carrying ram with small diameters made of solid material are used for handling carpet rolls
- Can be manufactured in any length and diameter and to suit any type or capacity of forklift.



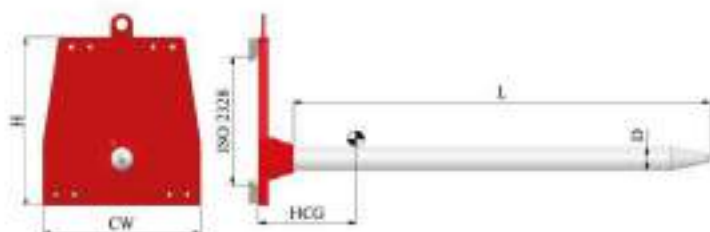

Catalogue Order No	Part No	Capacity (kg/m ²)	Chassis Width (mm)	Mounting Class	Beam Diameter (mm)	Beam Length (mm)	Height (mm)	Horizontal Centre of Gravity (mm)	Weight (kg)	Price
			CW	ISO3328	D	L	H	HCG	W	€
007CC-07BA3000	CC0703000	709	430	2A	70	3800	505	910	164	
006CC-07BA3500	CC0703500	607	430	2A	70	3500	505	1117	179	
005CC-07BA4000	CC0704000	532	430	2A	70	4800	505	1330	194	
004CC-07BA5000	CC0705000	425	430	2A	70	5800	505	1771	224	
021CC-075A1250	CC0751250	2100	430	2A	75	1250	505	301	117	
017CC-075A1500	CC0751500	1750	430	2A	75	1500	505	381	125	
013CC-075A2000	CC0752000	1312	430	2A	75	2000	505	363	143	
010CC-075A2500	CC0752500	1050	430	2A	75	2500	505	757	160	
008CC-075A3000	CC0753000	875	430	2A	75	3000	505	962	177	
007CC-075A3500	CC0753500	750	430	2A	75	3500	505	1178	195	
006CC-075A4000	CC0754000	656	430	2A	75	4800	505	1396	212	
005CC-075A5000	CC0755000	525	430	2A	75	5800	505	1849	247	

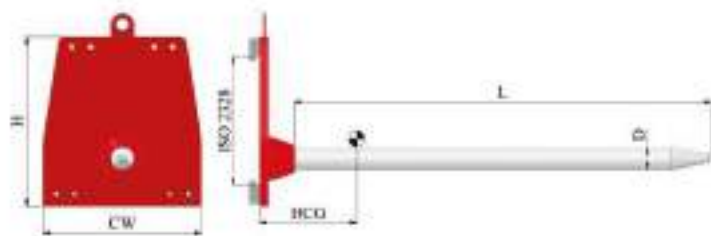

Catalogue Order No.	Part No.	Capacity (kg/m ²)	Chassis Width (mm)	Mounting Class	Ram Diameter (mm)	Ram Length (mm)	Height (mm)	Horizontal Centre of Gravity (mm)	Weight (kg)	Price
			CW	ISO 2328	D	L	H	HCG	W	€
025CC-088A1250	CC0801250	2531	410	2A	80	1250	505	322	125	
021CC-088A1500	CC0801500	2109	410	2A	80	1500	505	409	133	
015CC-088A2000	CC0802000	1582	410	2A	80	2000	505	595	152	
012CC-088A2500	CC0802500	1265	410	2A	80	2500	50	799	172	
010CC-088A3000	CC0803000	1054	410	2A	80	3000	505	1012	192	
069CC-088A3500	CC0803500	904	410	2A	80	3500	505	1232	212	
007CC-088A4000	CC0804000	791	410	2A	80	4000	505	1455	231	
066CC-088A5000	CC0805000	632	410	2A	80	5000	505	1917	271	
010CC-085A1250	CC0851250	3044	410	2A	85	1250	505	341	129	
025CC-085A1500	CC0851500	2536	410	2A	85	1500	505	432	140	
019CC-085A2000	CC0852000	1902	410	2A	85	2000	505	627	162	
015CC-085A2500	CC0852500	1522	410	2A	85	2500	505	838	185	

1 diameters made handling carpet rolls right and diameter of forklift.



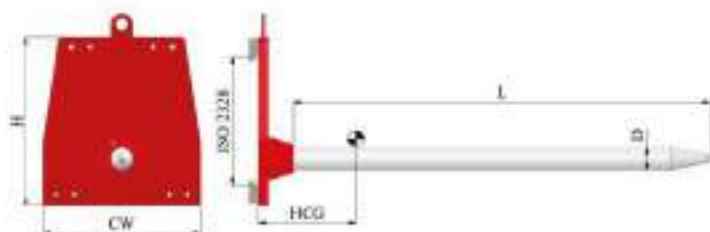

Catalogue Order No	Part No	Capacity (kg/mm)	Chassis Width (mm)	Mounting Class	Beam Diameter (mm)	Beam Length (mm)	Height (mm)	Horizontal Centre of Gravity (mm)	Weight (kg)	Price
			CW	ISO2328	D	L	H	HCG	W	€
012CC-085A3000	CC0853000	1268	410	2A	85	3000	505	1055	207	
010CC-085A3500	CC0853500	1087	410	2A	85	3500	505	1279	229	
009CC-085A4000	CC0854000	951	410	2A	85	4000	505	1507	251	
007CC-085A5000	CC0855000	761	410	2A	85	5000	505	1975	296	
015CC-098A1250	CC0901250	3391	410	2A	90	1250	505	361	136	
009CC-098A1500	CC0901500	2993	410	2A	90	1500	505	455	148	
022CC-098A2000	CC0902000	2244	410	2A	90	2000	505	658	173	
017CC-098A2500	CC0902500	1795	410	2A	90	2500	505	872	198	
014CC-098A3000	CC0903000	1496	410	2A	90	3000	505	1095	223	
012CC-098A3500	CC0903500	1282	410	2A	90	3500	505	1323	248	
011CC-098A4000	CC0904000	1122	410	2A	90	4000	505	1555	273	
008CC-098A5000	CC0905000	897	410	2A	90	5000	505	2028	323	

- Carpet carrying ram with small diameters made of solid material are used for handling carpet rolls.
- Can be manufactured in any length and diameter and to suit any type or capacity of forklift.



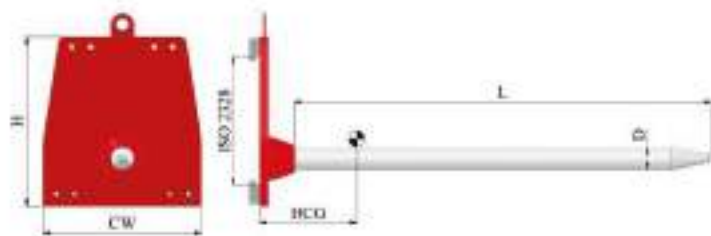

Catalogue Order No	Part No	Capacity (kg/mm)	Chassis Width (mm)	Mounting Class	Boom Diameter (mm)	Boom Length (mm)	Height (mm)	Horizontal Centre of Gravity (mm)	Weight (kg)	Price
			CW	ISO2124	D	L	H	HCG	W	€
821CC-075B1250	CC0751250	2100	580	3A	75	1250	612	213	178	
817CC-075B1500	CC0751500	1750	580	3A	75	1500	612	270	186	
813CC-075B2000	CC0752000	1312	580	3A	75	2000	612	408	204	
810CC-075B2500	CC0752500	1050	580	3A	75	2500	612	560	221	
806CC-075B3000	CC0753000	875	580	3A	75	3000	612	727	238	
807CC-075B3500	CC0753500	750	580	3A	75	3500	612	908	256	
806CC-075B4000	CC0754000	656	580	3A	75	4000	612	1094	275	
805CC-075B5000	CC0755000	523	580	3A	75	5000	612	1492	308	
825CC-080B1250	CC0801250	2531	580	3A	80	1250	612	230	184	
821CC-080B1500	CC0801500	2109	580	3A	80	1500	612	295	194	
815CC-080B2000	CC0802000	1582	580	3A	80	2000	612	438	215	
812CC-080B2500	CC0802500	1265	580	3A	80	2500	612	602	235	

- Carpet carrying ram with small diameters made of solid material are used for handling carpet rolls.
- Can be manufactured in any length and diameter and to suit any type or capacity of forklift.



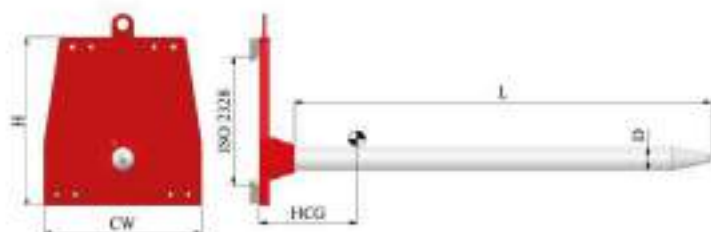

Catalogue Order No	Part No	Capacity (kg/ton)	Chassis Width (mm)	Mounting Class	Ram Diameter (mm)	Ram Length (mm)	Height (mm)	Horizontal Centre of Gravity (mm)	Weight (kg)	Price
			CW	ISO 2328	D	L	H	HCG	W	€
010CC-081B3000	CC0803000	1054	580	3A	80	3000	612	779	253	
009CC-081B3500	CC0803500	904	580	3A	80	3500	612	967	273	
007CC-081B4000	CC0804000	791	580	3A	80	4000	612	1160	292	
006CC-081B5000	CC0805000	632	580	3A	80	5000	612	1573	332	
010CC-085B1250	CC0851250	3044	580	3A	85	1250	612	246	190	
025CC-085B1500	CC0851500	2536	580	3A	85	1500	612	314	201	
019CC-085B2000	CC0852000	1900	580	3A	85	2000	612	468	223	
015CC-085B2500	CC0852500	1522	580	3A	85	2500	612	642	246	
012CC-085B3000	CC0853000	1268	580	3A	85	3000	612	825	268	
010CC-085B3500	CC0853500	1067	580	3A	85	3500	612	1019	290	
009CC-085B4000	CC0854000	951	580	3A	85	4000	612	1221	312	
007CC-085B5000	CC0855000	761	580	3A	85	5000	612	1645	357	

- Carpet carrying ram with small diameters made of solid material are used for handling carpet rolls.
- Can be manufactured in any length and diameter and to suit any type or capacity of forklift.



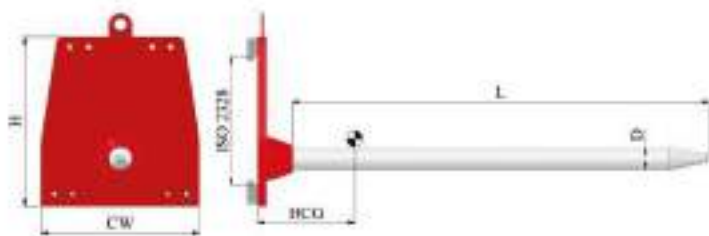

Catalogue Order No.	Part No.	Capacity (kg/ton)	Chassis Width (mm)	Mounting Class	Ram Diameter (mm)	Ram Length (mm)	Height (mm)	Horizontal Centre of Gravity (mm)	Weight (kg)	Price
			CW	ISO 2328	D	L	H	HCG	W	€
035CC-090B1250	CC0901250	3591	580	3A	90	1250	612	263	197	
029CC-090B1500	CC0901500	2993	580	3A	90	1500	612	336	209	
022CC-090B2000	CC0902000	2244	580	3A	90	2000	612	498	254	
017CC-090B2500	CC0902500	1795	580	3A	90	2500	612	678	259	
014CC-090B3000	CC0903000	1498	580	3A	90	3000	612	870	264	
012CC-090B3500	CC0903500	1282	580	3A	90	3500	612	1071	309	
011CC-090B4000	CC0904000	1122	580	3A	90	4000	612	1280	354	
009CC-090B5000	CC0905000	897	580	3A	90	5000	612	1713	384	
042CC-095B1250	CC0951250	4236	580	3A	95	1250	612	280	204	
035CC-095B1500	CC0951500	3530	580	3A	95	1500	612	357	218	
029CC-095B2000	CC0952000	2648	580	3A	95	2000	612	528	246	
021CC-095B2500	CC0952500	2118	580	3A	95	2500	612	712	273	

- Carpet carrying ram with small diameters made of solid material are used for handling carpet rolls.
- Can be manufactured in any length and diameter and to suit any type or capacity of forklift.



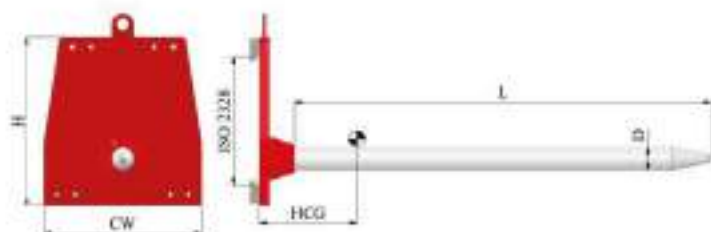

Catalogue Order No	Part No	Capacity (kg/m ²)	Chassis Width (mm)	Mounting Class	Boom Diameter (mm)	Boom Length (mm)	Height (mm)	Horizontal Centre of Gravity (mm)	Weight (kg)	Price
			CW	ISO2328	D	L	H	HCG	W	€
017CC-095B3000	CC0953000	1765	580	1A	95	3800	612	911	301	
015CC-095B3500	CC0953500	1513	580	1A	95	3500	612	1119	329	
013CC-095B4000	CC0954000	1324	580	1A	95	4800	612	1333	357	
010CC-095B5000	CC0955000	1059	580	1A	95	5800	612	1774	412	
049CC-100B1250	CC1001250	4955	580	1A	100	1250	612	297	212	
041CC-100B1500	CC1001500	4127	580	1A	100	1500	612	377	227	
030CC-100B2000	CC1002000	3095	580	1A	100	2000	612	355	258	
024CC-100B2500	CC1002500	2476	580	1A	100	2500	612	748	289	
020CC-100B3000	CC1003000	2063	580	1A	100	3000	612	951	319	
017CC-100B3500	CC1003500	1769	580	1A	100	3500	612	1163	350	
015CC-100B4000	CC1004000	1548	580	1A	100	4000	612	1382	381	
012CC-100B5000	CC1005000	1234	580	1A	100	5000	612	1832	443	

- Carpet carrying ram with small diameters made of solid material are used for handling carpet rolls.
- Can be manufactured in any length and diameter and to suit any type or capacity of forklift.



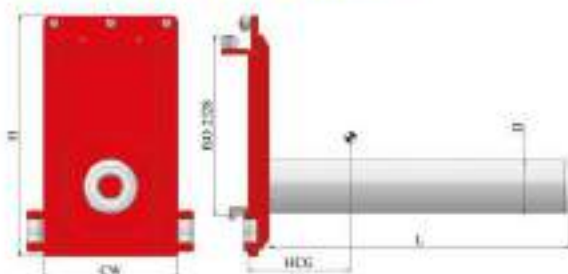

Catalogue Order No	Part No	Capacity (kg/mm)	Choasis Width (mm)	Mounting Class	Boom Diameter (mm)	Boom Length (mm)	Height (mm)	Horizontal Centre of Gravity (mm)	Weight (kg)	Price
			CW	ISO 2323	D	L	H	HCG	W	€
040FT-16A1200	FT0401612	4000	650	3A	160	1200	600	355	178	
060FT-20B1200	FT0602012	6000	700	4A	200	1200	700	446	315	
100FT-21B1200	FT1002112	10000	700	4A	250	1200	700	482	366	

- Coil booms are used for handling wire or steel coils, tubes or goods of a similar geometry.
- Can be manufactured in any length and diameter and to suit any type or capacity of forklift.



Wagner
Attachments

Wagner
Attachments
THINK BIG!
HOLD THE WORLD

THINK BIG!
HOLD THE WORLD

Wagner[®]

attachments

THINK BIG!

HOLD THE WORLD

Special Attachments

EMA	Fungus Mangalizer	12-1
CPC	Concrete Pipe Clamp	12-1
PTC	Tyre Clamp	12-2
PLY	Picker Layer	12-2
DPC	Castling Ladle Attachment	12-3
CDR	Box Dumpers With 360 Rotating	12-3
DAT	Drum Fickle	12-4
SPU	Load Extender	12-4
LSB	Load Subfloor	12-5
SPR-C33X	Forklift Scooper - Hydraulic	12-5
CAX	Cotton Bale Clamp - Tubular Class	12-6
TGT	Logging Tong Clamp Without Forks	12-6
EXF	Fork Positioner	12-7
EKF	Fork Positioner	12-7
YKT	Integral Side Shifter	12-8
YKY	Integral Side Shifter	12-8
FMB	Forklift Mast	12-8
RBR	180° Rotating Board	12-9
RGA	360° Rotating Koyote Clamp	12-10
DAZ	180° Rotating Drum Clamp	12-10
DAV	360° Rotating Drum Clamp	12-10
DAX	360° Rotating Drum Clamp	12-10
HT	Hydraulic Jib Boom	12-11
CR	Fork Extension For Circle Loads	12-11
QC	Quick Coupling	12-11
BB	Big Bag Attachments	12-11
YD	Load Buckrest	12-14
FB	Forklift Board	12-14
SCE	Load Extender	12-15
HBA	Hinged Bucket Attachment	12-18
CPT	360° Rotating Pallet Inverter	12-15
RBD	180° Box/Retainer	12-15
CPC	360° Rotating Pallet Inverter	12-17
CPH	200° Rotating Pallet Inverters with Side Panel	12-17
HFA	Hinged Fork Attachment	12-18
RTC	360° Rotating Tyre Clamp	12-18
PHC	Pipe Handler with Fork Positioner	12-19



**SILAGE
MASTER**



Waggoner **X**series

| 12



Special
Attachments

FMA SPECIAL ATTACHMENTS
Forging Manipulator



CPC SPECIAL ATTACHMENTS
Concrete Pipe Clamp



PTC SPECIAL ATTACHMENTS
Tyre Clamp

Wagner[®]
attachments



PLY SPECIAL ATTACHMENTS
Smart Layer Picker



DPC SPECIAL ATTACHMENTS
Casting Ladge Attachment



CDR SPECIAL ATTACHMENTS
Box Dumpers With 360° Rotating



DAT SPECIAL ATTACHMENTS
Drums Pickle

Wagner®
attachments



SPU SPECIAL ATTACHMENTS
Load Extender



LSB

SPECIAL ATTACHMENTS

Load Stabilizer

Wagner[®]
attachments



SPR-C33X

SPECIAL ATTACHMENTS

Forklift Sweeper - Hydraulic



CAX

SPECIAL ATTACHMENTS

Cotton Bale Clamp - Tubular Chassis

Wagner[®]
attachments



TGT

SPECIAL ATTACHMENTS

Logging Tong Clamp Without Forks



FXF**SPECIAL ATTACHMENTS**

Fork Positioner

Wagner
attachments**FKF****SPECIAL ATTACHMENTS**

Fork Positioner



YKT

SPECIAL ATTACHMENTS

Integral Side Shifter

Wagner[®]
attachments



YKY

SPECIAL ATTACHMENTS

Integral Side Shifter



FMB SPECIAL ATTACHMENTS
Forklift Mast



RBR SPECIAL ATTACHMENTS
180° Rotator Board



RGA

SPECIAL ATTACHMENTS

360° Rotating Keystone Clamp

Wagner[®]
Attachments



DAZ

SPECIAL ATTACHMENTS

180° Rotating Drum Clamp



DAV SPECIAL ATTACHMENTS
360° Rotating Drum Clamp

Wagger[®]
attachments



DAX SPECIAL ATTACHMENTS
360° Rotating Drum Clamp



HT**SPECIAL ATTACHMENTS**

Hydraulic Jim Boom

Wagner[®]
attachments**CR****SPECIAL ATTACHMENTS**

Forks Extension For Circle Loads

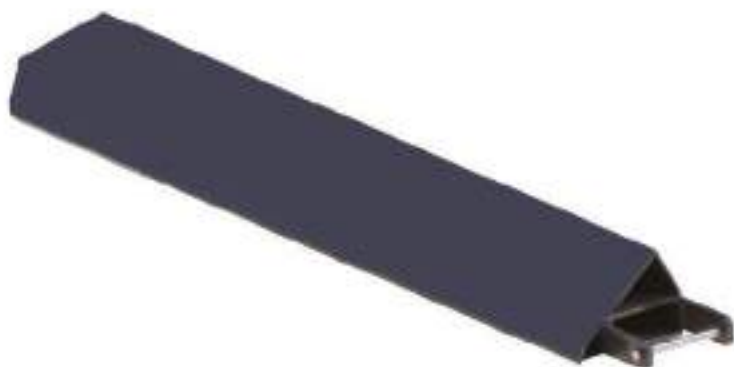

QC

SPECIAL ATTACHMENTS

Quick Coupling

Wagner[®]
attachments



BB

SPECIAL ATTACHMENTS

Big Bag Attachments



YD

SPECIAL ATTACHMENTS

Load Backrest

Wagner[®]
attachments



FB

SPECIAL ATTACHMENTS

Forklift Board



SCE SPECIAL ATTACHMENTS
Load Extender

Wagner[®]
attachments



HBA SPECIAL ATTACHMENTS
Hinged Bucket Attachment



CPT SPECIAL ATTACHMENTS
360° Rotating Pallet Inverter

Wagner[®]
attachments

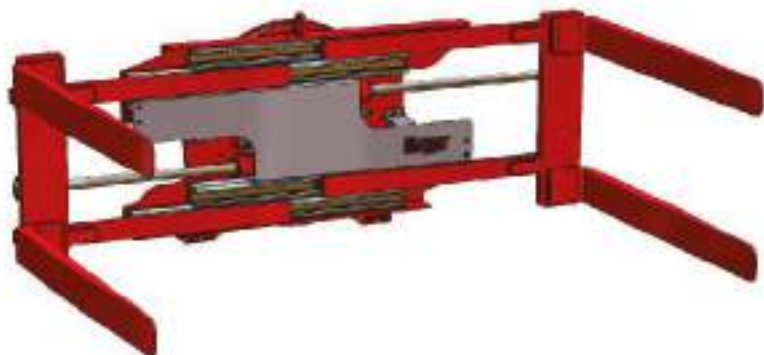

RBD SPECIAL ATTACHMENTS
180° Box Rotator



CPC SPECIAL ATTACHMENTS
360° Rotating Pallet Inverter

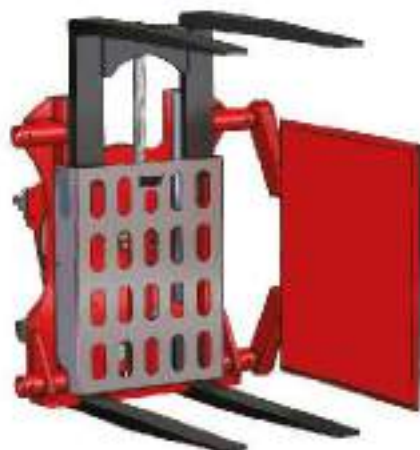

CPT SPECIAL ATTACHMENTS
360° Rotating Pallet Inverter with Side Panel

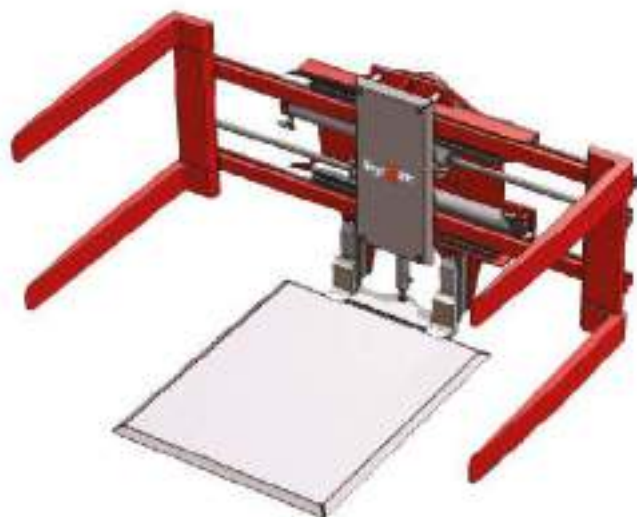

HFA SPECIAL ATTACHMENTS
Hinged Fork Attachment

Wagner®
attachments



RTC SPECIAL ATTACHMENTS
360° Rotating Tyre Clamp



PHC SPECIAL ATTACHMENTS
Pipe Handler with Fork Positioner

Wagner[®]
attachments



Wagner[®]

attachments

THINK BIG!

HOLD THE WORLD



Wagner
green factory

30%
BETTER
ENERGY SAVINGS

50%
BETTER INDOOR
AIR QUALITY

20%
LESS WATER
CONSUMPTION

Waggoner®

attachments

THINK BIG!

HOLD THE WORLD

• material
handling
equipments •

ATTACHMENTS

paper roll clamps • rotators • coating clamps and pallet inverter
side chifter and fork positioners • bale clamps • white good clamps
multi pallet handlers • push and pull units • brick/block and hay bale clamps
buckets • mechanical attachments • special attachments

www.waggoner.com.tr