

**KÖNIG TOOLS®**

MATERIAL GERMANY

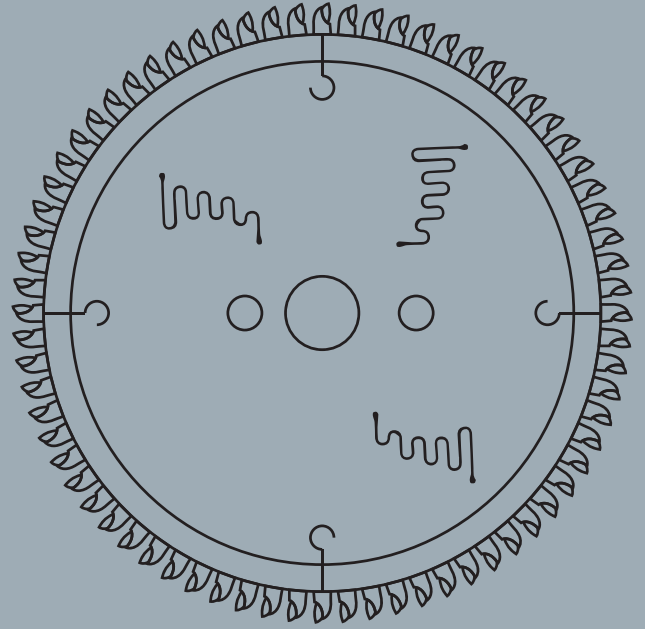
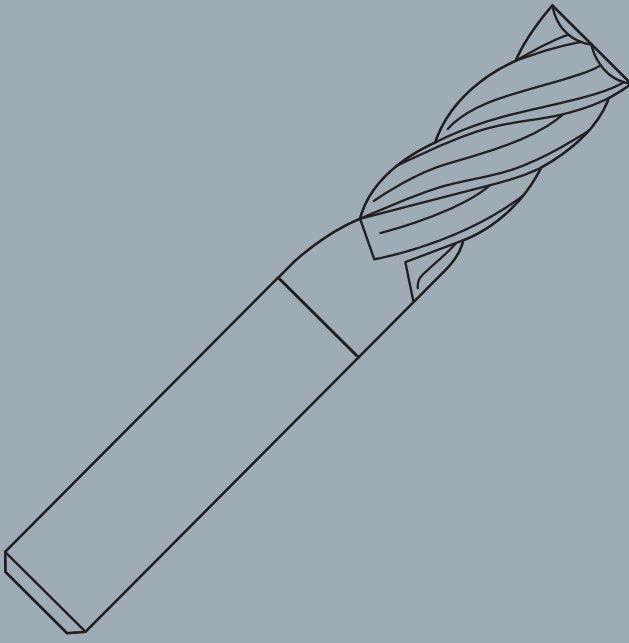

TT

TEKNİK TESTERE
A.Ş

2018

**KÖNIG TOOLS®**
MATERIAL GERMANY



**TT&**
TEKNİK TESTERE
A.Ş



www.tekniktestere.com.tr

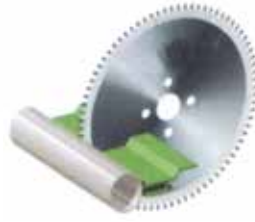

Negatif dişli: Değişik malzeme kalınlıkları olan sac Alüminyum Profil boru ve çubukların kesiminde özellikle kollar için uygundur.
Pozitif dişli: Malzeme kalınlığı 5 mm'den yukarı olan Alüminyum Profil borular ve çubukların kesiminde otomatik makinelerde tavsiye edilir.

With negative tooth: These saw blades are used in cutting of what having various thicknesses of sheet metals, bars, pipe, aluminum hollow sections and especially appropriate at the sleeved machines.

With positive tooth: These saw blades are advised in cutting for bars, aluminum hollow pipes that materials have over 5 mm thickness especially at the automatic machines.

Neg (NEGATIV): отрицательный угол заточки на 5°. Отрицательный угол образуется между передней режущей кромкой зуба и линией, проведённой от центра диска к передней режущей кромке зуба. Для отрезания пластиковых и алюминиевых профилей до 3 мм со скосом под углом 45°

Pos (POSITIV): положительный угол заточки зуба. Положительный угол образуется между передней режущей кромкой зуба и линией, проведённой от центра диска к передней режущей кромке зуба.

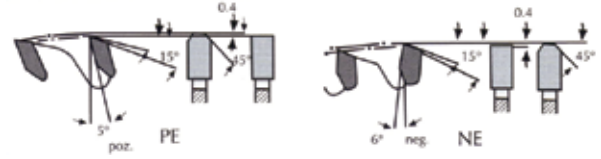

Code/Kod/Артикул	D	B	D	Z
ALM-115-01	115	4,0	22	20
ALM-140-01	140	2,2	30	48
ALM-150-01	150	3	30	48
ALM-160-01	160	2,2	30	48
ALM-170-01	170	3,0	30	48
ALM-180-01	180	3,0	30	48
ALM-180-02	180	3,0	30	58
ALM-190-01	190	2,0	30	58
ALM-190-02	190	3,0	30	58
ALM-200-01	200	3,0	30	40
ALM-200-02	200	3,0	30-32	64
ALM-200-03	200	2,0	30-32	64
ALM-200-04	200	2,0	32	72
ALM-210-01	210	2,0	30	64
ALM-210-02	210	3,0	30	64
ALM-230-01	230	3,0	30	36
ALM-230-02	230	3,2	30	62
ALM-235-01	235	3,0	30	30
ALM-250-01	250	3,2	30-32	60
ALM-250-02	250	3,2	30-32	80
ALM-250-03	250	2,0	30	80
ALM-270-01	270	2,4	30	48
ALM-270-02	270	3,0	30	88
ALM-275-01	275	2,4	30	48
ALM-280-01	280	2,5	30	64
ALM-280-02	280	3,2	32	88
ALM-300-01	300	3,2	30	48
ALM-300-02	300	3,2	30	60
ALM-300-03	300	3,2	30-32	72
ALM-300-04	300	3,2	30-32	96
ALM-300-05	300	2,0	30-32	96
ALM-305-01	305	3,2	30	96
ALM-320-01	320	3,2	32	96
ALM-330-01	330	3,6	32	108
ALM-350-01	350	3,6	30-32	84
ALM-350-02	350	2,4	30-32	96

Code/Kod/Артикул	D	B	D	Z
ALM-350-03	350	3,6	30-32	108
ALM-355-01	355	2,0	30	50
ALM-380-01	380	3,6	30	56
ALM-380-02	380	3,6	32	110
ALM-400-01	400	4,0	30	60
ALM-400-02	400	4,0	30	72
ALM-400-03	400	4,0	30-32	96
ALM-400-04	400	4,0	30-32	108
ALM-400-05	400	4,0	30-32	120
ALM-420-01	420	2,8	30	60
ALM-420-02	420	4,0	30	72
ALM-420-03	420	2,8	30	80
ALM-420-04	420	4,0	30-32	96
ALM-420-05	420	4,0	30-32	108
ALM-420-06	420	4,0	30-32	120
ALM-450-01	450	4,0	30	72
ALM-450-02	450	4,0	30	96
ALM-450-03	450	4,0	30-32	108
ALM-450-04	450	4,0	32	120
ALM-500-01	500	4,0	30	60
ALM-500-02	500	4,0	30	72
ALM-500-03	500	4,0	40	96
ALM-500-04	500	4,0	30	108
ALM-500-05	500	4,0	30-32	120
ALM-500-06	500	4,0	30	138
ALM-500-07	500	4,0	30	160
ALM-550-01	550	4,4	50	68
ALM-550-02	550	4,4	30	72
ALM-550-03	550	4,4	30	96
ALM-550-04	550	4,4	30-32	120
ALM-600-01	600	4,4	50	72
ALM-600-02	600	4,4	30	96
ALM-600-03	600	4,4	30	120
ALM-600-04	600	4,4	30	138
ALM-600-05	600	4,4	30	160



PLASTİK-PVC TESTERELERİ (CRV)

SAWS FOR PLASTIC AND PVC

Фрезерные пилы для резки ПВХ штапика

Code/Kod/ARTIKUL	D	B	D	Z
CK-200-01	200	2,0	32	80
CK-200-02	200	1,8	32	160
CK-250-01	250	2,0	32	100
CK-250-02	250	2,5	32	100
CK-300-01	300	2,5	32	120

Code/Kod/ARTIKUL	D	B	D	Z
PVC-200-01	200	1,3	32	180
PVC-250-01	250	1,3	32	230
PVC-300-01	300	1,3	32	280
PVC-350-01	350	1,3	32	360
PVC-400-01	400	1,3	40	410
PVC-450-01	450	2,0	40	410
PVC-500-01	500	2,5	40	410

ÇİTA KESME FREZESİ 45° (HSS)

GLAZING BEAD SAWS

ПОДРЕЗНЫЕ ПИЛЫ ДЛЯ РЕЗКИ ШТАПИКА 45°

Code/Kod/ARTIKUL	D	B	D	Z
FRZ-95-01	95	2,5	32	80
FRZ-95-03	95	2,5	32	80
FRZ-100-01	100	3,0	32	80
FRZ-100-02	100	4,0	22	80
FRZ-100-03	100	4,0	32	80
FRZ-103-01	103	2,0	32	80
FRZ-110-01	110	4,0	20	80
FRZ-115-01	115	4,0	22	80
FRZ-120-01	120	4,0	22	80
FRZ-120-02	120	4,0	27	80
FRZ-125-01	125	4,0	22	80

ELMAS UÇLU ÇİTA KESME FREZESİ (HM)

CARBIDE TIPPED SAWS FOR GLAZING BEAD

ФРЕЗЕРНЫЕ ПИЛЫ ДЛЯ РЕЗКИ ПВХ И АЛЮМИНИЕВОГО ШТАПИКА

Code/Kod/ARTIKUL	D	B	D	Z	YÖN
EUT-175-01	175	2,1	20	68	pos-WZ
EUT-200-01	200	2,1	30	60-100	neg
EUT-200-02	200	2,2	30-32	100	neg
EUT-200-03	200	2,1	32	80-100	neg-pos
EUT-225-01	225	2,2	32	88-100	neg
EUT-250-01	250	2,1	20	120	neg

ELMAS UÇLU ÇİTA KESME FREZESİ 45° (HM)

45 DEGREE FRAISES FOR GLAZING BEAD

ПОДРЕЗНЫЕ ПИЛЫ ДЛЯ РЕЗКИ ПВХ ШТАПИКА 45°

Code/Kod/ARTIKUL	D	B	D	Z	YÖN
EFT-92-01	92	3,0	30	24	L/R
EFT-95-01	95	2,1	20	20	L/R
EFT-98-01	98	3,0	32	36	L/R
EFT-103-01	103	2,1	32	24	L/R
EFT-103-02	103	2,1	32	40	L/R
EFT-150-01	150	4,0	32	32	L/R
EFT-175-01	175	3,2	32	56	L/R

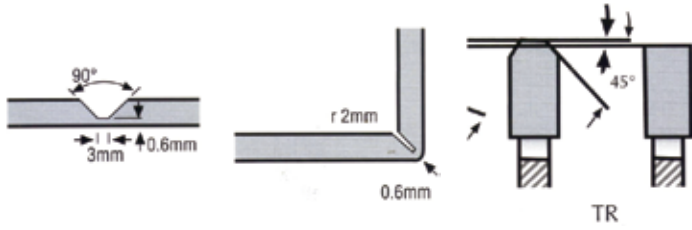
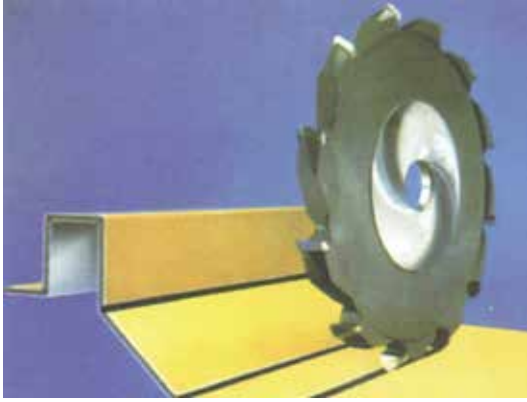

Code/Kod/ ARTIKUL	D	B	d	Z
ALC-150-01	150	8,0	30	18
ALC-150-02	150	10,0	30	18
ALC-180-01	180	8,0	30	18
ALC-180-02	180	8,5	30	18
ALC-180-03	180	10,0	30	18
ALC-180-04	180	8,0	30	24
ALC-180-05	180	10,0	30	24
ALC-200-01	200	8,0	30	18
ALC-200-02	200	8,5	30	18
ALC-200-03	200	10,0	30	18
ALC-200-04	200	8,0	30	24
ALC-200-05	200	10,0	30	24

KERTME BIÇAKLARI (Polar 1, Polar2, Aldox, Festool)

Fold Grooving Cutters (Polar 1, Polar2, Aldox, Festool)

Пильные диски для зачистки торца импоста (Polar 1, Polar2, Aldox, Festool)



Code/Kod/ ARTIKUL	D	B	d	Z
KRT-86-02	86	4.5	30	10
KRT-87-02	87	4.3	30	10
KRT-120-01	120	5.2	30	14
KRT-127-01	127	4.5	30	12
KRT-128-01	128	4.5	30	12
KRT-162-01	161	6.0	30	18

DRY CUT, METAL VE SANDVIÇ PANEL KESİCİLER

Cold / Dry-Cut Metal and Sandwich Panel Cutter Blades

Пильные диски для резки металла и сэндвич-панелей (DRY CUT)

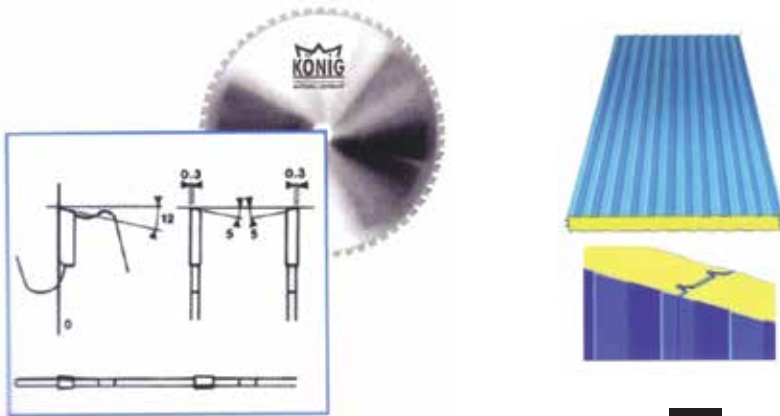

D	B	d	Z
180	2.2	20	34
190	2.2	20	38
210	2.2	30	40
230	2.2	30	44
305	2.2	25.4	80
355	2.4	25.4	80



Çap D (mm)	Kalınlık B (mm)
250	2,5
300	2,5
300	3,0
350	2,5
350	3,0
400	3,0
400	4,0
450	3,0
450	4,0
500	3,0
500	4,0
500	5,0
500	6,0
520	3,0
520	4,0
520	5,0
520	5,5
520	6,0
550	3,0
550	4,0
550	5,0
550	5,5
550	6,0
560	4,0
560	5,0
560	5,0
560	6,0
580	4,0
580	5,0
580	5,5
580	6,0
600	4,0
600	5,0
600	5,5
600	6,0

Çap D (mm)	Kalınlık B (mm)
600	7,2
610	4,0
610	5,0
610	5,0
610	6,0
620	4,0
620	5,0
620	5,5
620	6,0
630	4,0
630	5,0
630	5,5
630	6,0
630	7,0
650	4,0
650	5,0
650	5,5
650	6,0
650	7,0
660	5,0
660	6,0
660	7,0
700	4,0
700	5,0
700	5,5
700	6,0
700	7,0
750	5,0
750	5,5
750	6,0
750	7,0
760	5,0
800	5,0
800	5,5
800	6,0

Çap D (mm)	Kalınlık B (mm)
800	7,0
800	8,0
850	6,0
850	7,0
850	8,0
900	6,0
900	7,0
900	8,0
900	9,0
950	7,0
950	8,0
950	9,0
1000	6,0
1000	7,0
1000	8,0
1000	9,0
1000	10
1050	7,0
1050	8,0
1050	9,0
1050	10
1100	7,0
1100	8,0
1100	9,0
1100	10
1200	7,0
1200	8,0
1200	9,0
1200	10
1250	7,0
1250	8,0
1250	9,0
1250	10

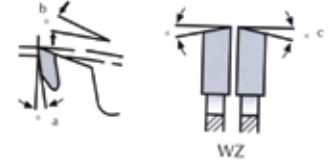

Kod No	D	B	d	Z	Bileme açıları		
					a	b	c
AHS-100-01	100	3,0	30	18	10	15	15
AHS-150-01	150	3,0	30	24	13	15	10
AHS-150-02	150	3,0	30	48	10	15	15
AHS-160-01	160	3,0	30	24	13	15	10
AHS-160-02	160	3,0	30	48	10	15	15
AHS-180-01	180	3,0	30	24	13	15	10
AHS-180-02	180	3,0	30	30	13	15	10
AHS-180-03	180	3,0	30	40	13	15	10
AHS-180-04	180	3,0	30	48	10	15	15
AHS-200-01	200	3,0	30	40	13	15	10
AHS-200-02	200	3,0	30	48	10	15	15
AHS-200-03	200	3,0	30	64	5	18	15
AHS-250-01	250	3,2	30	40	13	15	15
AHS-250-02	250	3,2	30	48	13	15	15
AHS-250-03	250	3,2	30	60	10	15	15
AHS-250-04	250	3,2	30	80	5	18	15
AHS-300-01	300	3,2	30	48	13	15	10
AHS-300-02	300	3,2	30	60	10	15	15

Kod No	D	B	d	Z	Bileme açıları		
					a	b	c
AHS-300-03	300	3,2	30	72	10	15	15
AHS-300-04	300	3,2	30	96	5	18	15
AHS-350-01	350	3,6	30	54	13	15	10
AHS-350-02	350	3,6	30	72	13	15	15
AHS-350-03	350	3,6	30	84	10	15	15
AHS-350-04	350	3,6	30	108	5	18	15
AHS-400-01	400	3,8	30	60	15	15	15
AHS-400-02	400	3,8	30	72	10	15	15
AHS-400-03	400	3,8	30	96	10	15	15
AHS-400-04	400	3,8	30	120	5	18	15
AHS-450-01	450	4,0	30	54	13	15	10
AHS-450-02	450	4,0	30	72	13	15	10
AHS-450-03	450	4,0	30	120	10	15	15
AHS-500-01	500	4,0	30	60	10	15	15
AHS-500-02	500	4,0	30	72	10	15	15
AHS-500-03	500	4,0	30	96	10	15	15
AHS-500-04	500	4,0	30	120	10	15	15

ELMAS UÇLU ATLAMALI BG DİŞLİ AHŞAP DAİRE TESTERELERİ
Carbide/Diamond-Tipped Precision Circular Saw Blade, BG Tooth

Пильные диски для продольного пиления

Yumuşak ağaç kontratbla,
Yonga levha kesimlerinde kullanılır.

Kod No	D	B	d	Z
BG-200-01	200	3,0	30	20
BG-250-01	250	3,2	30	24
BG-300-01	300	3,2	30	28
BG-350-01	350	3,6	30	32
BG-400-01	400	3,8	30	36
BG-400-02	400	3,8	30	42
BG-450-01	450	4,0	30	42
BG-500-01	500	4,0	30	48
BG-550-01	550	4,0	30	48
BG-600-01	600	4,0	30	56
BG-600-02	600	4,4	30	56

LİSTEMİZDE BULUNMAYAN ÖLÇÜLER,
İSTEK ÜZERİNE 15 İŞ GÜNÜNDE İMAL EDİLİR

ПРИЁМ ЗАКАЗОВ ПО ВАШИМ ЧЕРТЕЖАМ,
СРОК ИЗГОТОВЛЕНИЯ 15 ДНЕЙ

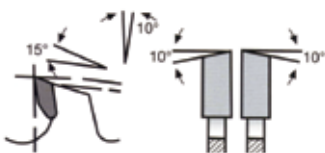

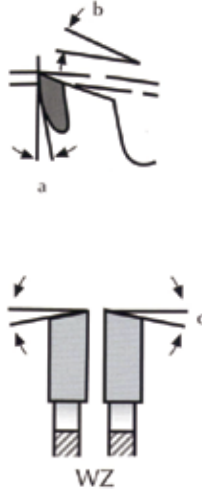
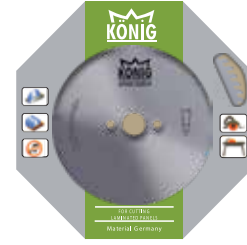

Kod No	D	B	d	Z	Bileme açıları		
					a	b	c
MSF-200-01	200	2,4	30	30	15	15	15
MSF-200-02	200	2,4	30	40	13	15	15
MSF-200-03	200	2,4	30	64	5	18	15
MSF-250-01	250	2,4	30	24	18	15	15
MSF-250-02	250	2,4	30	40	13	15	15
MSF-250-03	250	2,4	30	48	13	15	15
MSF-250-04	250	2,4	30	60	10	15	15
MSF-250-05	250	2,4	30	80	5	18	15
MSF-300-01	300	2,4	30	28	18	15	15
MSF-300-02	300	2,4	30	48	15	15	15
MSF-350-01	350	2,4	30	54	15	15	15

LİSTEMİZDE BULUNMAYAN ÖLÇÜLER,
İSTEK ÜZERİNE 15 İŞ GÜNÜNDE İMAL EDİLİR
ПРИЁМ ЗАКАЗОВ ПО ВАШИМ ЧЕРТЕЖАМ,
СРОК ИЗГОТОВЛЕНИЯ 15 ДНЕЙ

ELMAS UÇLU PORTATİF MAKİNALAR İÇİN DAİRE TESTERELER

Carbide/Diamond-Tipped Circular Saw-Blades For Portable/Site Saws

Пильные диски для деревообрабатывающих портативных станков



Portatif el makinelerinde sunta, kontraplak kontratable kesiminde ayrıca sert ve yumuşak ağaçların dilimlenmesinde kullanılır.

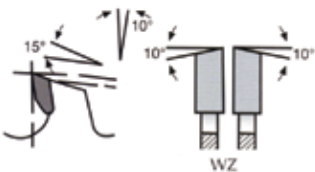

Kod No	D	B	d	Z
PRT-100-01	100	2,4	20	12
PRT-110-01	110	2,4	20	18
PRT-115-01	115	2,4	20	12
PRT-115-02	115	2,4	20	18
PRT-125-01	125	2,4	20	24
PRT-127-01	127	2,4	20	12
PRT-130-01	130	2,4	20	24
PRT-140-01	140	2,4	20	24
PRT-150-01	150	2,4	20	24
PRT-150-02	150	2,4	20	48
PRT-160-01	160	2,4	20	24
PRT-160-02	160	2,4	20	48
PRT-165-01	165	2,4	20	24
PRT-170-01	170	2,4	20	24
PRT-180-01	180	2,4	20	24
PRT-180-02	180	2,4	20	40
PRT-180-03	180	2,4	30	48
PRT-185-01	185	2,4	20	24
PRT-185-02	185	2,4	20	40
PRT-190-01	190	2,4	20	24
PRT-190-02	190	2,4	30	24
PRT-190-03	190	2,4	20	40
PRT-190-04	190	2,4	30	40
PRT-210-01	210	2,4	30	24
PRT-210-02	210	2,4	30	32
PRT-210-03	210	2,4	30	48
PRT-230-01	230	2,4	30	36
PRT-235-01	235	2,4	30	36



Kod No	D	B	d	Z	Bileme açıları		SESSİZ
					a	b	
TRF-180-01	180	2,4	30	58	6	15	
TRF-190-02	190	2	30	58	5	18	
TRF-200-01	200	3,0	30	48	6	15	
TRF-200-02	200	3,0	30	64	5	18	
TRF-200-03	200	2,4	30	64	5	18	
TRF-200-04	200	2	30	64	5	18	
TRF-220-01	220	3,3	30	64	5	18	
TRF-230-01	230	3	30	72	6	15	
TRF-230-02	230	3,3	30	64	6	15	
TRF-250-01	250	3,2	30	60	6	15	
TRF-250-02	250	2	30	80	6	15	
TRF-250-03	250	3,2	30	80	5	18	
TRF-250-04	250	2,4	30	80	5	18	
TRF-280-01	280	3,2	30	64	6	15	
TRF-280-02	280	3,2	30	88	6	15	
TRF-300-01	300	3,2	30	80	6	15	
TRF-300-02	300	3,2	30	72	6	15	
TRF-300-03	300	3,2	30	96	5	15	
TRF-300-04	300	2,0	30	96	5	18	
TRF-350-01	350	3,6	30	84	5	18	
TRF-350-02	350	4,0	30	108	12	18	
TRF-400-01	400	4,0	30	72	12	15	
TRF-400-02	400	4,0	30	96	5	15	
TRF-400-03	400	4,0	30	120	12	18	
TRF-450-01	450	4,0	30	72	12	15	
TRF-450-02	450	4,0	30	120	5	18	
TRF-500-01	500	4,2	30	120	5	18	

MDF Laminant suntalam, plywood ve kaplamalı malzemelerin kesimlerinde, hassas ebatlamada kullanılır.

ELMAS UÇLU ÇİZİCİ TESTERELERİ

Diamond-Tipped, Marker Saw Blades

Подрезные пильные диски



Laminant Suntalam ve kaplamalı plakaların kesiminde alt yüzeyden ön çizimi yapılarak kırılmayı önler.

Kod No	D	B	d	Z
CZC-100-01	100	2,8-3,8	20	20
CZC-120-01	120	3,0-4,0	20	24
CZC-125-01	125	2,8-3,8	20	24
CZC-125-02	125	3,0-4,0	20	24
CZC-125-03	125	3,2-4,2	30	24
CZC-150-01	150	3,0-4,0	20	36
CZC-150-02	150	3,4-4,4	20	36
CZC-150-03	150	4,2-5,2	20	36
CZC-160-01	160	3,0-4,0	30	24
CZC-160-02	160	4,2-5,2	30	24
CZC-180-01	180	3,4-4,4	30	24
CZC-180-02	180	3,0-4,0	30	24
CZC-180-03	180	4,3-5,3	30	36
CZC-200-01	200	3,2-4,2	30	34
CZC-200-02	200	4,2-5,2	30	34
CZC-220-01	220	3,3	20	64
CZC-220-02	220	3,0-4,0	20	64

LİSTEMİZDE BULUNMAYAN ÖLÇÜLER,
İSTEK ÜZERİNE 15 İŞ GÜNÜNDE İMAL EDİLİR

ПРИЁМ ЗАКАЗОВ ПО ВАШИМ ЧЕРТЕЖАМ,
СРОК ИЗГОТОВЛЕНИЯ 15 ДНЕЙ

ELMAS UÇLU KANAL TESTERELERİ

Carbide/Diamond-Tipped Groove-Cutting Blades

Пазовые пильные диски

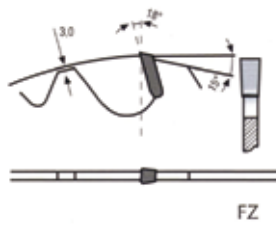
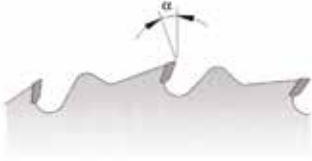
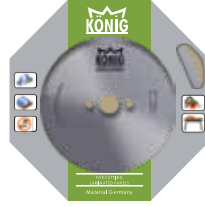

AHŞAP KESİMİNDE KULLANILAN DAİRESEL TESTERELER (ELMASSIZ)

Standard Circular Wood Blades

Пильные диски по дереву без напаяк



Kod No	D	B	d	Z
KNL-150-01	150	4,0	30	12
KNL-150-02	150	4,0	30	18
KNL-150-03	150	5,0	30	12
KNL-150-04	150	5,0	30	18
KNL-150-05	150	6,0	30	12
KNL-150-06	150	6,0	30	18
KNL-150-07	150	8,0	30	12
KNL-150-08	150	8,0	30	18
KNL-150-09	150	10,0	30	12
KNL-150-10	150	10,0	30	18
KNL-180-01	180	4,0	30	12
KNL-180-02	180	4,0	30	18
KNL-180-03	180	4,4	30	18
KNL-180-04	180	5,0	30	12
KNL-180-05	180	5,0	30	18
KNL-180-06	180	6,0	30	12
KNL-180-07	180	6,0	30	18
KNL-180-08	180	8,0	30	12
KNL-180-09	180	8,0	30	18
KNL-180-10	180	9,0	30	12
KNL-180-11	180	9,0	30	18
KNL-180-12	180	10,0	30	12
KNL-180-13	180	10,0	30	18
KNL-200-01	200	4,0	30	12
KNL-200-02	200	4,0	30	18
KNL-200-03	200	4,4	30	18
KNL-200-04	200	5,0	30	12
KNL-200-05	200	5,0	30	18
KNL-200-06	200	6,0	30	12
KNL-200-07	200	6,0	30	18
KNL-200-08	200	8,0	30	12
KNL-200-09	200	8,0	30	18
KNL-200-10	200	9,0	30	12
KNL-200-11	200	9,0	30	18
KNL-200-12	200	10,0	30	12
KNL-200-13	200	10,0	30	18

LİSTEMİZDE BULUNMAYAN ÖLÇÜLER,
İSTEK ÜZERİNE 15 İŞ GÜNÜNDE İMAL EDİLİR

ПРИЁМ ЗАКАЗОВ ПО ВАШИМ ЧЕРТЕЖАМ,
СРОК ИЗГОТОВЛЕНИЯ 15 ДНЕЙ

Kod No	D	B	d	Z
EA-100-01	100	0,90	16-20	72
EA-125-01	125	0,90	20	72
EA-150-01	150	1,0	20	72
EA-175-01	175	1,1	20-30	72
EA-200-01	200	1,5	30	76
EA-200-02	200	3,0	40	72
EA-250-01	250	1,5	30	76
EA-250-02	250	3,0	40	72
EA-300-01	300	1,8	30	76
EA-350-01	350	1,8	30	76
EA-400-01	400	2,0	30	76
EA-450-01	450	2,2	30	76
EA-500-01	500	2,5	30	56
EA-600-01	600	2,8	30	56
EA-700-01	700	3,5	40	56
EA-800-01	800	3,5	40	56

LİSTEMİZDE BULUNMAYAN ÖLÇÜLER,
İSTEK ÜZERİNE 15 İŞ GÜNÜNDE İMAL EDİLİR

ПРИЁМ ЗАКАЗОВ ПО ВАШИМ ЧЕРТЕЖАМ,
СРОК ИЗГОТОВЛЕНИЯ 15 ДНЕЙ

TTS 101



132 KG
620 x 740 x 1350

TTS 201



103 KG
1060 x 500 x 1000

TTS 301



65 KG
710 x 450 x 1115

TTS 401



108 KG
630 x 630 x 1230

TTS 402



320 KG
1000 x 1460 x 1460

TTS 501



160 KG
1000 x 700 x 1380

TTS 601



115 KG
620 x 920 x 1400

TTS 111



140 KG
620 x 740 x 1350

TTS 101A



22 KG
670 x 500 x 520

TTS 631



38 KG
600 x 430 x 650

TTS 321



38 KG
495 x 340 x 500

TT 300



30 KG
400 x 620 x 415

KÖNIG TOOLS®

MATERIAL GERMANY



TT
TEKNİK TESTERE
A.Ş



Arapcami Mah. Bakır Sk. Aslan Han No:1
Kat: 5 (503,504,505,507,508,509,510)
Karaköy - İSTANBUL / TURKEY

+ 90 (212) 237 90 80

+ 90 (212) 237 01 75

www.tekniktestere.com.tr

info@tekniktestere.com.tr