

**Genel Ürün Kataloğu**  
*Product Catalogue*



# HAKKIMIZDA ABOUT US

Ankara'da toplam 500.000 m<sup>2</sup>'lik açık ve kapalı üretim alanlarına sahip Pi Makina, yaklaşık 1000 personeli ile bölgesinde lider bir kuruluş olarak modern ve yenilikçi birçok iş kolunu aynı çatı altında toplamıştır. Proje, Ar-Ge, Test ve Kalite kontrol departmanları, Cnc işleme, Talaşlı imalat, Isıl işlem, Boyama ve Kumlama merkezleri öne çıkan birimlerdir. Kalite politikasının da öngördüğü gibi sürekli iyileştirme yaklaşımıyla gelişmiş teknoloji kullanıp, zamanında ve kaliteli üretim yaparak müşteri memnuniyeti sağlanmaktadır. Beton santrallerinden beton pompalarına, kule vinçlerden kırma eleme tesislerine, kazıcı yükleyicilerden ekskavatörlere... güçlü, verimli ve güvenilir iş ve inşaat makinaları ile projenizi tam zamanında ve düşük maliyetlerle tamamlamaktadır. Ayrıca satış sonrası hizmetler ile sadece Türkiye'de değil dünyanın bir çok ülkesinden müşterilerine 7/24 servis ve yedek parça hizmeti sunmaktadır. Pi Makina size işinizi zamanında ve belirlediğiniz bütçe dahilinde bitirmeniz için, etkili, güçlü ve güvenilir iş ve inşaat makinaları üretiyor. "Pi Makina sizin için çalışan makinalar üretiyor..."

Pi Makina has accomplished a remarkable achievement in offering better solutions for customers business need. In our 500.000 sqm manufacturing plant, located in Ankara, Pi Makina employees around 1000 personnel. Our facility is a pioneer in the are by offering multiple, modern and innovative solutions under same room. The prominent units are Project and R&D departments, CNC Machinery Center, Heat Treatment Center, Test Centers, Sand Blasting, Paint Drying Unit, Total Quality Control Unit After sale service offers 7 days and 24 hours service and spare parts in Turkey as well as various countries around the world. Whenever you choose Pi Makina construction equipment, you get efficient, powerful and reliable machines that help you to accomplish any task within budget and on time. From concrete plants to concrete pumps, tower cranes to crushing plants, backhoe loaders to excavators...

"Pi Makina has the products that works for you..."

**Beton Santrali**  
Conc. Batching Plant



**1971**

**Beton Finiřeri**  
Concrete Finisher



**1973**

**Beton Pompası**  
Concrete Pump



**1981**

**Ekskavatör**  
Excavator



**1983**

**1972**



**Pi Makina Fabrikası Kuruldu**  
Pi Makina Factory Established

**1979**



**Transmikser**  
Truckmixer

**1980**



**Kazıcı Yükleyici**  
Backhoe Loader

**1982**



**Kule Vinç**  
Tower Crane

# Türkiye'de İLK, hep biz olduk.

We have always been the first one.

**Silindir**  
Cylinder



1986

**Yükleyici**  
Loader



1990

**Kamyon**  
Truck



2011

**Çekici Tır**  
Trailer Truck



2015

1988



**Greyder**  
Grader

1993



**Paletli Dozer**  
Crawler Dozer

2016



**Pi Makina 2. Fabrikası Kuruldu**  
Pi Makina 2. Factory Established



# **İŞ MAKİNALARI**

*EARTH MOVING MACHINES*





# 1022A

## BACKHOE LOADER KAZICI YÜKLEYİCİ

Yüksek kova ve kol koparma kuvvetine sahiptir. Özel muz bom kazıcısı ile kolay yükleme sağlayan Pİ 1022A' nın opsiyonel teleskobik bomu sayesinde de kazma mesafesi daha da arttırılabilir. Opsiyonel, kolay sökölüp takılan ataşmanları ile hızlı ve güvenilir çözümler sunmaktadır. Yastıklamalı kazıcı silindirleri ile uzun ömürlü ve sarsıntısız bir kullanım sağlar.

With its high arm, bucket breakout forces and banana boom, Pi 1022A provides great convenience in digging and loading. Digging depth can be extended by optional telescopic boom. Ease of installation and removal of the optional attachments, provide quick and reliable solutions. Cushioning in Backhoe Hydraulic Cylinders absorbs shocks, enables smoother operation and prolongs the life span of the machine.

MOTOR	ENGINE
Marka, Model	Model Perkins 1104D-44T
Motor Gücü	Total Power 100 Hp (74.5 kW) ISO 14396
Maksimum Tork	Maximum Torque 392 Nm@1400 rpm
Motor Hacmi	Engine Size 4.4 lt
Silindir Sayısı	Number of Clynders 4
Motor Devri	Rated Speed 2200 rpm

ŞANZIMAN	TRANSMISSION
Carraro Power Syncro Otomatik Ağır Hizmet tipi	Carraro Power Syncro Auto. Heavy Duty
Senkromeç Tipi 4 İleri 4 Geri Vites	Synchromesh Type, 4 Forward, 4 Reverse

HİDROLİK SİSTEM	HYDRAULIC SYSTEM
Sessiz yüksek verimli uzun ömürlü dişli tip pompa	Silent, high effcent, long lasting, gear type
Pompa Debisi : 118 l/dk (2200 d/dk)	Pump Flow Rate : 118 l/min (2200 rpm)
Basınç: 250 bar	Pressure: 250 bar

AĞIRLIK	WEIGHT
Standart makine çalışma ağırlığı: 7950 kg*	Standard machine operating weight: 7950 kg*

YÜRÜYÜŞ HIZI	TRAVEL SPEED
1.Vites	1.Gear 6.1 km/h
2.Vites	2.Gear 9.8 km/h
3.Vites	3.Gear 21 km/h
4.Vites	4.Gear 41.1 km/h

# PERKINS

Motor  
Engine

## 100 HP

Maksimum Güç  
Maximum Power

## 1.2 m<sup>3</sup>

Kova Kapasitesi  
Bucket Capacity

\*Ataşmanlara göre değişiklik gösterebilmektedir.  
\*The weight may change according to attachments.

**LASTİKLER**

Ön	Front	16 / 70 - 20 12 PR
Arka	Rear	16.9 - 28 12 PR

**FRENLER**

Tip: Hidrolik Akümülatör  
Yağ Banyolu Çok Diskli

**BRAKES**

Type: Hydraulic Accumulator  
Wet Multi Disc

Arka Aks Üzerinde Mekanik Park Freni

Mechanical Parking Brake on the Rear Axle

**SERVİS DOLUM KAPASİTELERİ**

Yakıt Tankı	Fuel Tank	150 l
Hidrolik Depo	Hidrolik Depo	70 l
Motor Yağı	Motor Oil	8,5 l

**SERVICES REFILL CAPACITIES****AKSLAR**

Planet Tipi Carraro Akslar  
Salınım: Toplam 16 ° (Ön Aks)

**AXLES**

Planetary Type, Carraro  
Oscillation: 16 °( Front Axle)

Difransiyel Kilidi: Elektrik Kontrollü Arka Aks

Differential Lock: Electrically Controlled Rear Axles

Elektrik Kontrollü 4WD

Electrically Controlled 4WD

**ELEKTRİK SİSTEMİ**

Akü 12V - 105 Ah

**ELECTRICAL SYSTEM**

Battery 12V - 105 Ah

**DİREKSİYON**

Yüke Duyarlı, Yükseklik Ayarlı

**STEERING WHEEL**

Load Sensing, Height Adjustable

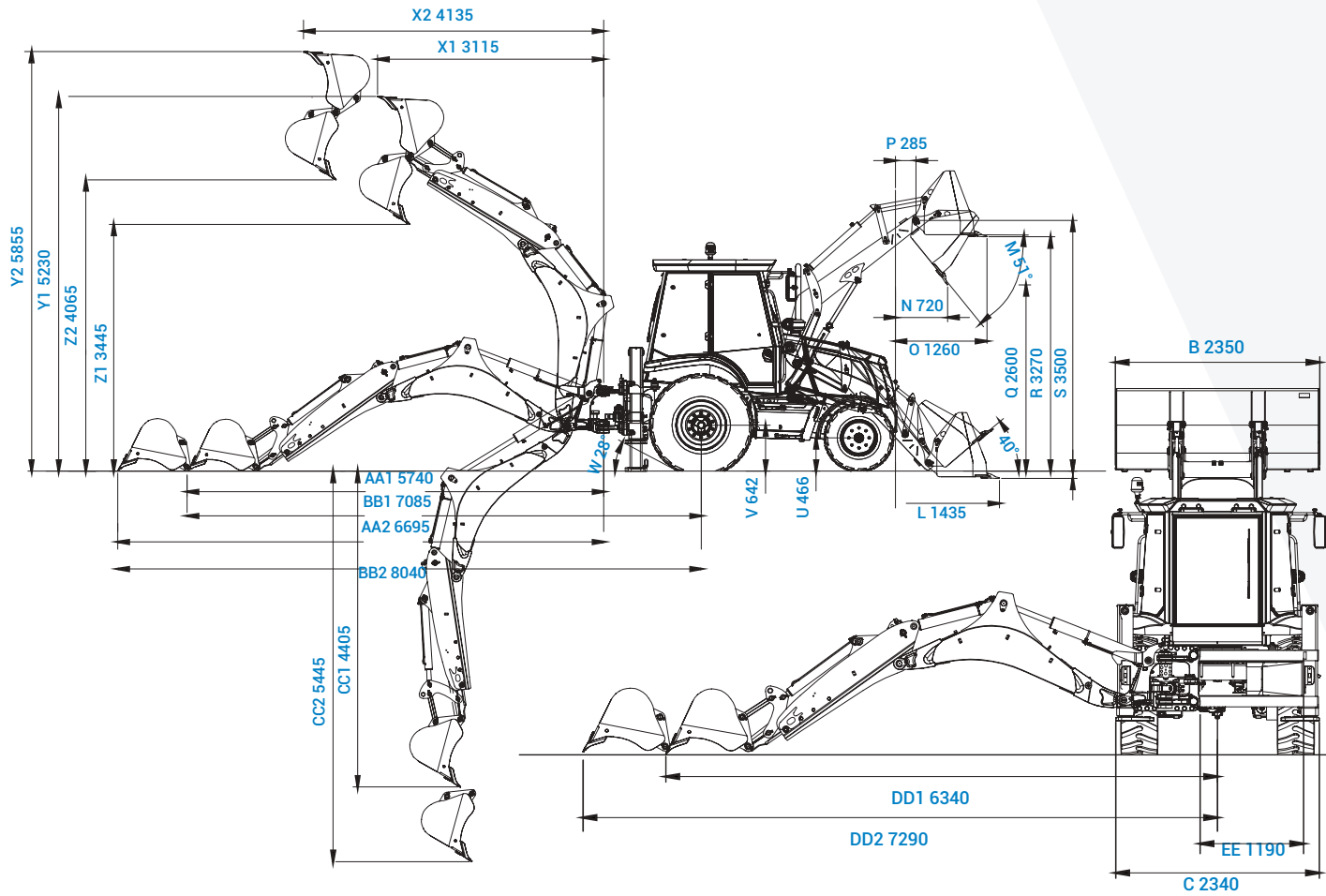

<b>L-</b>	Yerden Yükleyici Erişim Mesafesi	Loader Reach Distance From Ground	1435 mm
<b>M-</b>	Boşaltma Açısı	Dump Angle	51°
<b>N-</b>	Tam Yükseklikte Boşaltma Konumunda Erişim	Reach for Unloading Position At Full Dumped	720 mm
<b>O-</b>	Tam Yükseklikte Maksimum Erişim	Maximum Reach At Full Height	1 260 mm
<b>P-</b>	Pimden İleri Erişim Mesafesi	Reach Distance From Pin	285 mm
<b>Q-</b>	Maksimum Boşaltma Yükseklik	Maximum Dumping Height	2600 mm
<b>R-</b>	Maksimum Taşıma Yükseklik	Maximum Carrying Height	3270 mm
<b>S-</b>	Maksimum Pim Yükseklik	Maximum Pin Height	3500 mm
<b>T-</b>	Yükleyici Kazı Derinliği	Loader Excavation Depth	100 mm
<b>U-</b>	Ön Teker Merkez Yükseklik	Front Wheel Hub Height	465 mm
<b>V-</b>	Arka Teker Merkez Yükseklik	Rear Wheel Hub Height	640 mm
<b>W-</b>	Uzaklaşma Açısı	Departure Angle	28°
<b>X1-</b>	Tam Yüks. Dönüş Kulesi Merkezine Mesafe (SB)	Distance To Slew Center Center At Full Height (SB)	3115 mm
<b>X2-</b>	Tam Yüks. Dönüş Kulesi Merkezine Mesafe (TB)	Distance To Slew Center Center At Full Height (TB)	4135 mm
<b>Y1-</b>	Tam Yüks. Yerden Yükseklik (SB)	Height from Ground At Full Height (SB)	5230 mm
<b>Y2-</b>	Tam Yüks. Yerden Yükseklik (TB)	Height from Ground At Full Height (TB)	5855 mm
<b>Z1-</b>	Tam Yüks. Boşaltma Konumunda Yerden Yüks. (SB)	Height from Ground In Dumping Position At Full Height (SB)	3445 mm
<b>Z2-</b>	Tam Yüks. Boşaltma Konumunda Yerden Yüks. (TB)	Height from Ground In Dumping Position At Full Height (TB)	4065 mm
<b>AA1-</b>	Dönüş Mafsalından Kazıcı Erişim Mesafesi (SB)	Backhoe Reach Distance From Slew Center (SB)	5740 mm
<b>AA2-</b>	Dönüş Mafsalından Kazıcı Erişim Mesafesi (TB)	Backhoe Reach Distance From Slew Center (TB)	6695 mm
<b>BB1-</b>	Arka Akstan Kazıcı Erişim Mesafesi (SB)	Backhoe Reach Distance From Rear Axle (SB)	7085 mm
<b>BB2-</b>	Arka Akstan Kazıcı Erişim Mesafesi (TB)	Backhoe Reach Distance From Rear Axle (TB)	8040 mm
<b>CC1-</b>	Kazıcı Kazma Derinliği (SB)	Backhoe Dig Depth (SB)	4405 mm
<b>CC2-</b>	Kazıcı Kazma Derinliği (TB)	Backhoe Dig Depth (TB)	5445 mm
<b>DD1-</b>	Kazıcı Yana Maksimum Erişim (SB)	Backhoe Max. Side Reach (SB)	6340 mm
<b>DD2-</b>	Kazıcı Yana Maksimum Erişim (TB)	Backhoe Max. Side Reach (TB)	7290 mm
<b>EE-</b>	Kazıcı Kızak Hareket Mesafesi	Total Kingpost Travel	1190 mm

**KAZICI PERFORMANSI** **BACKHOE PERFORMANCE**

Kova Geniřlięi	Bucket Width	600 mm
Kova Kapasitesi	Bucket Capacity	0,20 m <sup>3</sup>
Kova Koparma Kuvveti	Bucket Breakout Force	54,6 kN
Kol Koparma Kuvveti	Arm Breakout Force	31,5 kN

**YÜKLEYİCİ PERFORMANSI** **LOADER PERFORMANCE**

Kova Geniřlięi	Bucket Width	2460 mm
Kova Kapasitesi	Bucket Capacity	1.2 m <sup>3</sup>
Kova Koparma Kuvveti	Bucket Breakout Force	58,1 kN
Kol Koparma Kuvveti	Arm Breakout Force	46,7 kN
Kaldırma Kapasitesi	Lift Capacity	3250 kg

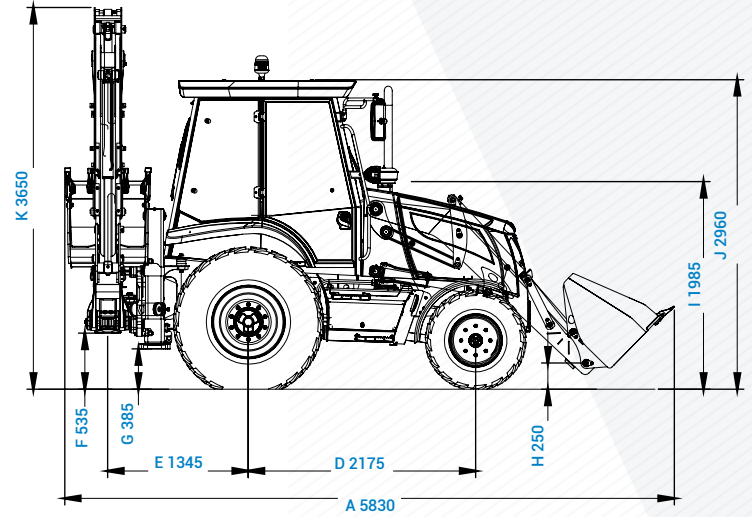

A-	Tam Uzunluk	Total Length	5830 mm
B-	Tam Geniřlik	Total Width	2350 mm
C-	Arka Őasi Geniřlięi	Rear Axle Kingpost Axis	2340 mm
D-	Dingil Mesafesi	Wheel Base	2175 mm
E-	Arka Aks Dönüř Kulesi Eksen	Rear Axle Kingpost Axis	1345 mm
F-	Dönüř Kulesi Yerden Yükseklik	Kingpost Clearance	535 mm
G-	Destek Ayakları Yerden Yükseklik	Support Legs Height From Ground	385 mm
H-	Yükleyici Kova Pim Yükseklik	Loader Bucket Pin Height	250 mm
I-	Direksiyon Merkezi Yerden Yükseklik	Height Over Cab From Ground	985 mm
J-	Yerden Kabin Üzerine Yükseklik	Steering Wheel Height	2960 mm
K-	Tam Yükseklik	Total Height	3650 mm







# 1051A

## WHEEL LOADER

# LASTİKLİ YÜKLEYİCİ

Yüksek performans ve düşük yakıt tüketimine sahip Pi 1051A, ergonomik kabin tasarımı ile operatörler için de maksimum konfor ve görüş alanına sahip olma özelliği ile rakipleri arasında öne çıkmaktadır. Boyut, güç ve performans özellikleri ile çok amaçlı kullanım için uygun olan Pi 1051A hidrostatik yürüyüş sistemi sayesinde hızlı çevrim zamanı sağlar ve ekonomik çözümler sunmaktadır.

Pi 1051A, steps forward through its competitors with its new ergonomic cab design providing maximum comfort and enhanced field of view for the operators besides its high performance and low fuel consumption. Through its dimensions, power and performance features, Pi 1051A is fitted to multi-purpose applications. Hydrostatic drive system provides shorter cycle time that leads economical solutions for Pi 1051A by moving more load in less time.

# CUMMINS

Motor  
Engine

## 140 HP

Maksimum Güç  
Maximum Power

## 1.7 / 2.0 / 2.4 m<sup>3</sup>

Kova Kapasitesi  
Bucket Capacity

### MOTOR

### ENGINE

Marka, Model	Model	Cummins Tier 3
Net Güç	Total Power	140 Hp / 104 kW (2000rpm)
Maksimum Tork	Maximum Torque	622 Nm@1500 rpm
Deplasman	Displacement	4.5 l
Silindir Adedi	Cylinder Number	4
Nominal Hız	Rated Speed	2200 rpm

### ŞANZIMAN

### TRANSMISSION

Şanzıman Tipi: Hidrostatik	Transmission Type: Hydrostatic	
Yürüyüş Hızı:	Travel Speed:	
Ağır Mod	Low Speed Mode	0-5 km/s
Ağır Mod	Low Speed Mode	0-35 km/s

### HİDROLİK SİSTEM

### HYDRAULIC SYSTEM

Yükleyici+Direksiyon Pompası: 153 l/dk (Pistonlu Pompa)	Loader+Steering Wheel pump 153 l/dk (Piston Pump)
Fren Pompası: 11 l/dk (Dişli Pompa)	Brake Pump: 11 l/min (Gear Pump)
Toplam Çevirme Zamanı: 12sn	Total Cycle Time: 12sec

### ELEKRİK SİSTEMİ

### ELECTRICAL SYSTEM

Akü 2 x 12V - 105 Ah	Battery 2 x 12V - 105 Ah
----------------------	--------------------------

### LASTİKLER

### TIRES

20.5 - 25

## SERVİS DOLUM KAPASİTELERİ

Yakıt Tankı: 198 l

Hidrolik Tank: 78 l

## AKSLAR

Tahrik Sistemi: 4 Çeker (4 x 4)

Ön Aks: Açık Diferansiyel

Arka Aks: Açık Diferansiyel

## FRENLER

Servis Frenleri: Tüm tekerlekler için hidrolik tahrikli disk fren. Her koşulda emniyet sağlayan çift devreli akümülatör desteklidir.

Park Frenleri: SAHR Sistem (Elektro Hidrolik)

## YÖNLENDİRME SİSTEMİ

Tip: Full Hidrostatik, Yüke Duyarlı

Yönlendirme Açısı: 40°

Acil Durum Direksiyon Sistemi (Elektro-hidrolik)

## KOVA KONTROLLERİ

Kontrol Pozisyonları;

Bom: Kaldırma, Tutma, Alçaltma ve Yüzdürme

Kova: Yükleme, Tutma ve Boşaltma

SRS (Opsiyonel)

## SERVICE REFILL CAPACITIES

Fuel Tank: 198 l

Hydraulic Tank: 78 l

## AXLES

Drive System: 4 Wheel Drive (4 x 4)

Front Axle: Open Differential

Rear Axle: Open Differential

## FRENLER

Service Brakes: Hydraulic drive disc brakes for all wheels. Double circuit accumulator ensures safety under all circumstances.

Service Brake: SAHR System (Electro-Hydraulic)

## STEERING SYSTEM

Type : Full Hydrostatic, load sensing

Steering Angle: 40°

Emergency Steering System (Electro-hydraulic)

## BUCKET CONTROLS

Control Positions;

Boom: Raise, Hold, Lower, Floating

Bucket: Load, Hold, Dump

SRS (Optional)

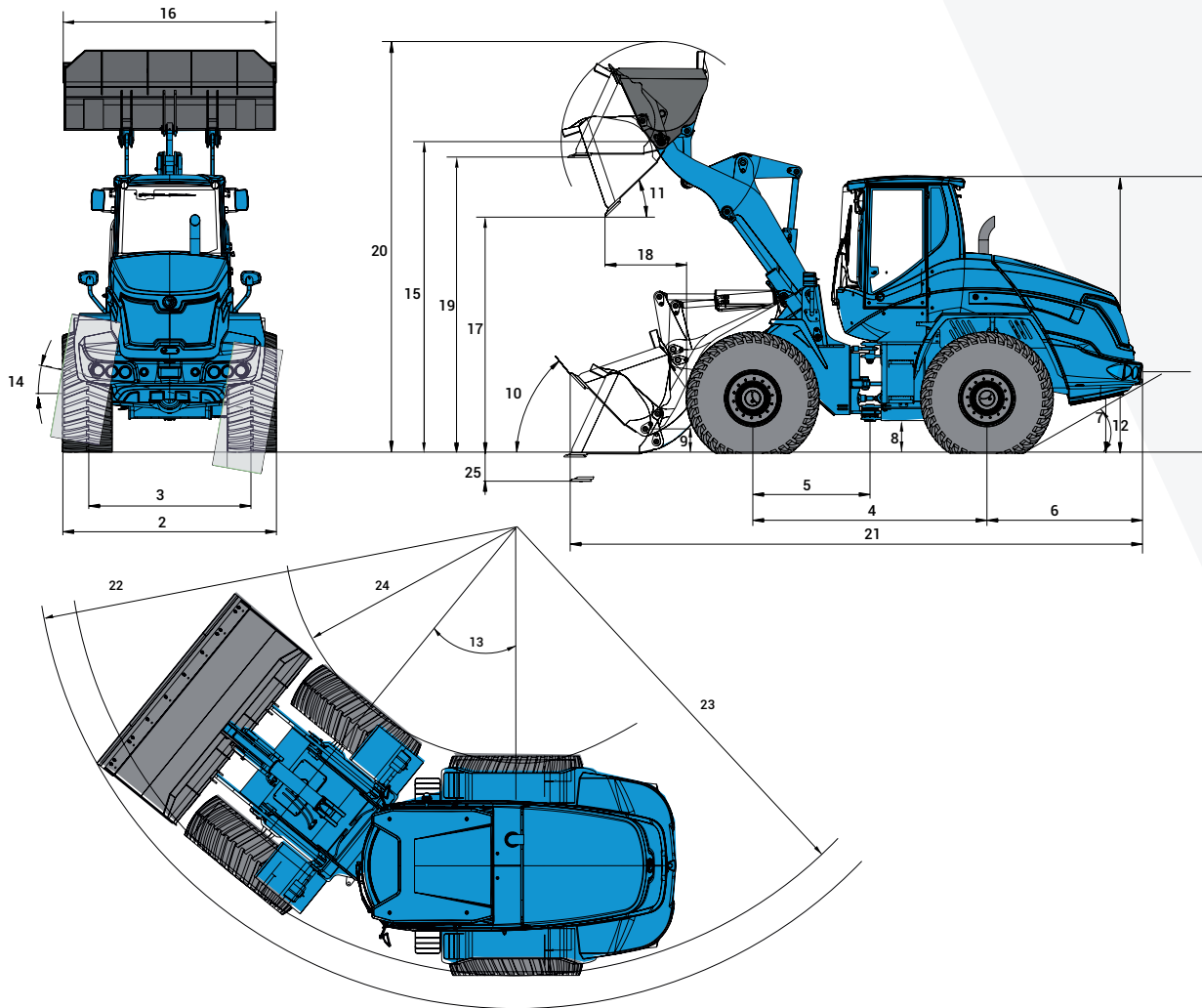

**20,5 - 25  
Lastik - Tires**

<b>1</b>	Toplam Yükseklik, Rops Kabin	<i>Overall Height, Rops Cap</i>	3330 mm
<b>2</b>	Lastik Dışından Genişlik	<i>Width Over Tires</i>	2440 mm
<b>3</b>	İz Genişliği	<i>Tread</i>	1920 mm
<b>4</b>	Dingil Aralığı	<i>Wheelbase</i>	2750 mm
<b>5</b>	Belden Kıрма Mafsalı, Ön Aks Merkezi	<i>Centre line of front axle to hitch</i>	1380 mm
<b>6</b>	Kontra Ağırlık - Arka Aks Merkezi	<i>Length - Rear Axle to Counter Weight</i>	1830 mm
<b>7</b>	Çeki Pimi Yüksekliği	<i>Hitch Height</i>	1005 mm
<b>8</b>	Zemin Açıklığı	<i>Ground Clearance</i>	455 mm
<b>9</b>	Taşıma Pozisyonunda Kova Pim Yüksekliği	<i>Hinge Pin Height at Carry Position</i>	400 mm
<b>10</b>	Taşıma Pozisyonunda Kova Açısı	<i>Rack Back Angle at Carry</i>	46°
<b>11</b>	Maksimum Yükseklikte Devirme Açısı	<i>Dump Angle at Maximum Lift</i>	45°
<b>12</b>	Arka Yaklaşma Açısı	<i>Departure Angle</i>	29°
<b>13</b>	Yönlendirme Açısı	<i>Articulation Angle</i>	40°
<b>14</b>	Arka Aks Salınımı	<i>Rear Axle Oscillation</i>	±10°
<b>15</b>	Maksimum Kova Pim Yüksekliği	<i>Hinge Pin Height at Maksimum Height</i>	3740 mm

## Cıvatalı Ağız Bıçakları

Bolt - On Cutting Edge

		Kova Tipi Bucket Type	Kazıcı Kovalı Excavating Bucket	İstiflenmiş Yük Stockpile Bucket	Hafif Malzeme Light Material Bucket
	Kova Kapasitesi: Yığma	Bucket Capacity: Heaped	1,7 m <sup>3</sup>	2,0 m <sup>3</sup>	2,4 m <sup>3</sup>
	Kova Kapasitesi: Silme	Bucket Capacity: Struck	1,5 m <sup>3</sup>	1,7 m <sup>3</sup>	2,0 m <sup>3</sup>
16	Kova Geniřlięi	Bucket Width	2500 mm	2500 mm	2550 mm
17	Maksimum Yükseklikte Kova Ucu Yükseklięi (Devrilmiş Durumda)	Dump Clearance at Maximum Lift and 45 ° Dump Angle	2865 mm	2745 mm	2660 mm
18	Yükleme Pozisyonundaki Yanışma Mesafesi ( Devrilmiş Durumda)	Reach at Maximum Lift and 45 ° Dump Angle	985 mm	1000 mm	1080 mm
19	Kova Altı Yükseklięi	Clearance: Level Bucket	3550 mm	3470 mm	3470 mm
20	Çalışma Yüks. (Kova Tam Kaldırılmış)	Operating Height (Fully Raised)	4925 mm	4970 mm	5065 mm
21	Toplam Uzunluk (Kova Yer Seviyesinde)	Overall Length (Bucket on Ground)	6760 mm	6940 mm	7055 mm
22	Dönüş Yarıçapı Kova Referanslı	Turning Radius: Over Bucket	5475 mm	5510 mm	5580 mm
23	Dönüş Yarıçapı Dış Teker Referanslı	Turning Radius: Outside of Tires	5050 mm	5050 mm	5050 mm
24	Dönüş Yarıçapı İç Teker Referanslı	Turning Radius: Inside of Tires	2560 mm	2560 mm	2560 mm
25	Kazma Derinlięi : 0°	Digging Depth: 0°	45 mm	125 mm	125 mm
	Statik Devrilme Yüğü: Düz	Static Tipping Load : Straight	11560 kg	11075 kg	10970 kg
	Statik Devrilme Yüğü: 40°	Static Tipping Load : 40°	10210 kg	9780 kg	9690 kg
	Koparma Kuvveti	Breakout Force	10290 kg	9315 kg	8405 kg
	* Çalışma Ağırlığı	* Operating Weight	11675 kg	11700 kg	11780 kg

\*Çalışma ağırlığı seçilen opsiyonlara göre deęişlik gösterebilir

\*Total working weight may change according to options

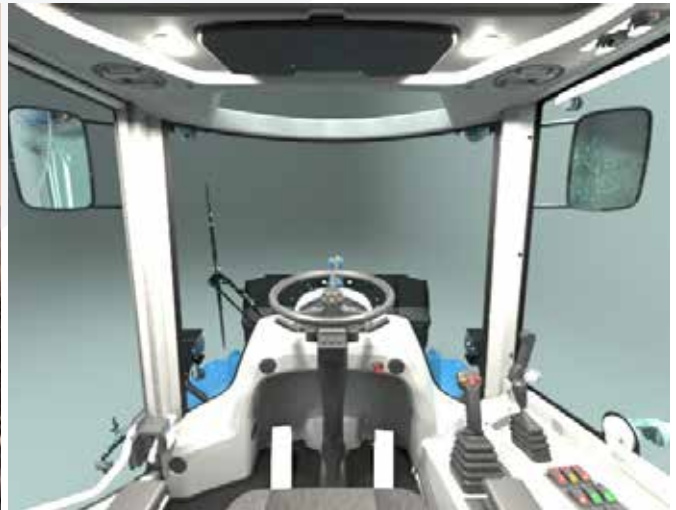





# 3180 A

## GRADER GREYDER

Pi 3180 A, esnek bıçak tablası yerleşimi ve uzun dingil mesafesi ile sahada yüksek işgücü; güvenli, ergonomik ve geniş görüş açısı sunan kabini ile operasyon kolaylığı ve yakıt verimliliği ile ekonomik uzun ömür sunar.

Pi 3180 A provides great convenience in material handling with its flexible moldboard positioning and long wheelbase. With its operational efficiency, improved visibility, service ease and overall performance, Pi 3180 A is one move ahead of your expectations.

**MOTOR**

Motor

Maksimum Güç

Maksimum Tork

Motor Hacmi

Silindir Adedi

**ENGINE**

Engine

Max Power

Max Torque

Engine Size

Number of Cylinders

Cummins

220Hp (164 kW) @ 2200 rpm

700 lb ft (949 Nm) @ 1500 rpm

6.7 lt

6

**ŞANZIMAN**Dana Powershift Ağır Hizmet Tipi  
ŞanzimanYüksek Enerji Kapasiteli 6 İleri, 3 Geri  
Otomatik VitesPreslenmiş Çelik Tork Konvertör 340  
mm**TRANSMISSION**Dana Powershift Heavy Duty Type  
TransmissionHigh Energy Capacity Clutches, 6 Fwd,  
3 Rvs Automatic GearsStamped Steel-Freewheel Stand  
Torque Converter 340 mm**HİDROLİK SİSTEM**Değişken Debili Pistonlu Pompa ve Dişli Tan-  
dem Pompa

Pompa Debisi: 132+105,6 l/dk (@ 2200 rpm)

Maks. Sistem Basıncı: 250 bar

**HYDRAULIC SYSTEM**Axial Piston variable Pump and Tandem  
Gear Pump

Pump Flow Rate: 132+105,6 l/min (@ 2200 rpm)

Max. System Pressure: 250 bar

**YÜRÜYÜŞ HIZLARI**

6 İleri, 3 Geri, Maksimum Hız: 38,3 km/s

**TRAVEL SPEED**

6 Forward, 3 Rear, Max Speed: 38,3 km/h

**ELEKTRİK SİSTEMİ**

Akü 2 x 12 V - 135 Ah - 880A

**ELECTRICAL SYSTEM**

Battery 2 x 12 V - 135 Ah 880 A

**CUMMINS**Motor  
Engine**220 HP**Maksimum Güç  
Maximum Power**3658 mm**Bıçak Geniřlięi  
Blade Length

## LASTİKLER

Ön / Arka : 14.00 - 24 16 PR

## TİRES

Front / Rear : 14.00 - 24 16 PLY

## FRENLER

Servis freni: Pedal çalıştırılmalı, 4 tandem tekerleğine etkili hidrolik fren

## BRAKES

Service Brake: Pedal actuated efficient on four tandem wheels

Park freni: Elle çalıştırılır, yay etkili, hidrolik olarak çözülen kaliper

Parking Brake: Hand actuated, spring loaded hydraulic release parking brake.

## YAKIT SİSTEMİ

Yakıt Tipi: Dizel

## FUEL SYSTEM

Fuel Type: Diesel

Yakıt Deposu: 273 l

Fuel tank: 273 l

## DİREKSİYON

Ayarlanabilir Direksiyon kolonu

## STEERING

Adjustable Steering Column

Basınç Tahliyeli Hidrostatik Yönlendirme Sistemi

Hydrostatic Steering System Complete With Pressure Relief

Anti Şok ve Anti Kaviteasyon Vafleri

Anti Shock And Anti Cavitation Valve

## AĞIRLIK

Standart makine çalışma ağırlığı: 16,080 kg

## WEIGHT

Standard machine operating weight: 16,490 kg

Ripper ile çalışma ağırlığı: 17,550 kg

Operating weight with ripper: 17,550 kg

## AKSLAR

Ön Aks

Yönlendirme Açısı:  $\pm 48^\circ$

Yana Yatma Açısı:  $\pm 19^\circ$

Artikülasyon Açısı:  $\pm 18^\circ$

Tandem Aks

Tip: Planet

Tahrik Sistemi: Zincir Tahrikli

Osilasyon Açısı  $\pm 15^\circ$

## AXLES

Ön Aks

Steering Angle:  $\pm 48^\circ$

Lean Angle:  $\pm 19^\circ$

Articulation Angle:  $\pm 18^\circ$

Tandem Axle

Type: Planetary

Drive System: Chain Drive

Oscillation Angle  $\pm 15^\circ$

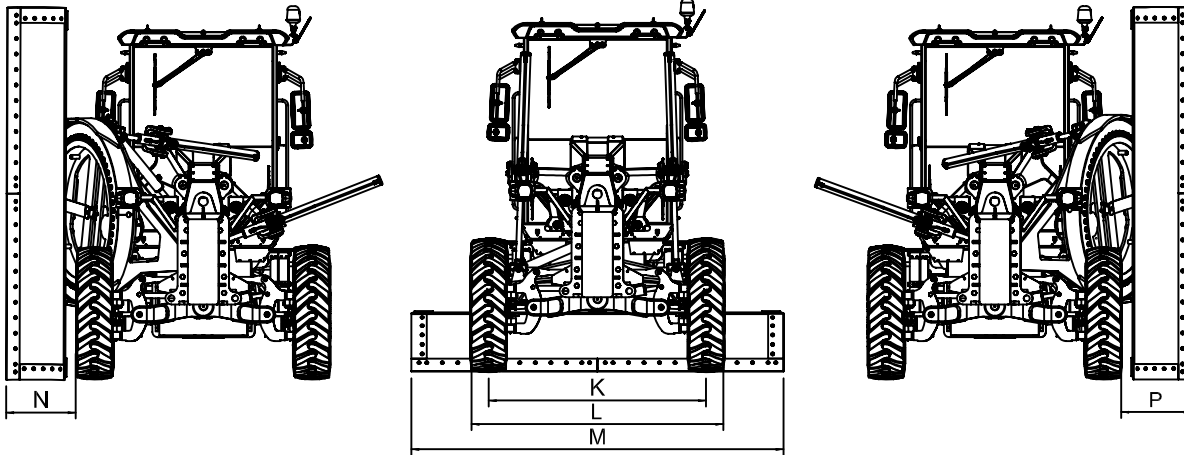

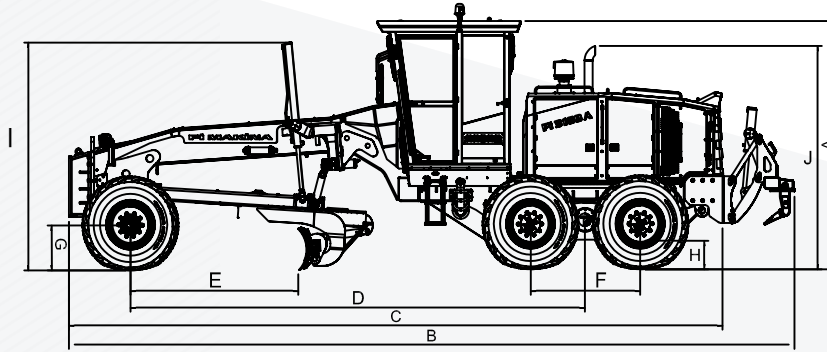

A. Yükseklik- yüksek profilli kabin	A. Height - high profile cab	3418 mm
B. Riperli makina uzunluğu	B. Length - with ripper	10152 mm
C. Makina uzunluğu	C. Length - without ripper	9147 mm
D. Ön akstan orta tendeme mesafe	D. Length - front axle to mid tandem	6363 mm
E. Uç Bıçaktan ön aks eksenine mesafe	E. Length - front axle to moldboard	2350 mm
F. Tandem aks arası mesafe	F. Length - between tandem axles:	1542 mm
G. Ön aks yüksekliği	G. Height to axle	630 mm
H. Yerden ara şanzımana mesafe	H. Ground clearance at trans. case	405 mm
I. Silindirlerin üzerine yükseklik	I. Height to top of cylinders	3142 mm
J. Egzos borusu üzerine yükseklik	J. Height to exhaust stack	3081 mm
K. Lastik iz genişliği	K. Width - tire center lines	2136 mm
L. Ön lastik dışından genişlik	L. Width - outside front tires	2500 mm
M. Bıçak uzunluğu	M. Length - blade	3658 mm
N. Sağ ön lastik dışından, bıçak şev mesafe	N. Distance btw. outside right front tyre to blade in slope position.	687 mm
P. Sol ön lastik dışından, bıçak şev mesafe	P. Distance btw. outside left front tyre to blade in slope position.	696 mm

**BIÇAK TABLASI****MOLDBOARD**

Bıçak Uzunluğu	Blade Length	3658 mm
Bıçak Yüksekliği	Blade Height	610 mm
Bıçak Kalınlığı	Blade Thickness	25 mm
Orta Bıçak	Cutting Edge Thickness	16 mm
Yan Bıçak	End Bits Thickness	16 mm
Maks. Bıçak Pozisyon Açısı	Max. Blade Position Angle	Sol-Sağ 90° Left-Right 90°

**RIPER****RIPPER**

Çalışma Aralığı	Operating Range	1055 mm
Kazma Derinliği	Scrafying Depth	440 mm
Tırnak Sayısı	Ripper Shanks	5 adet / unit
Tırnak Mesafesi	Shank Spacing	528 mm
Ağırlık	Weight	1145 kg

**KONTRA AĞIRLIK****COUNTERWEIGHT**

Ağırlık	Weight	321 kg
Boyutlar	Dimension	310 x 750 x 947,5 mm

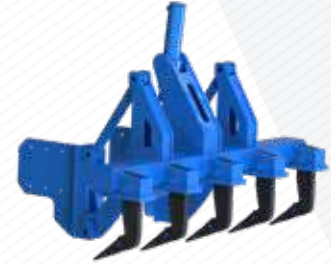



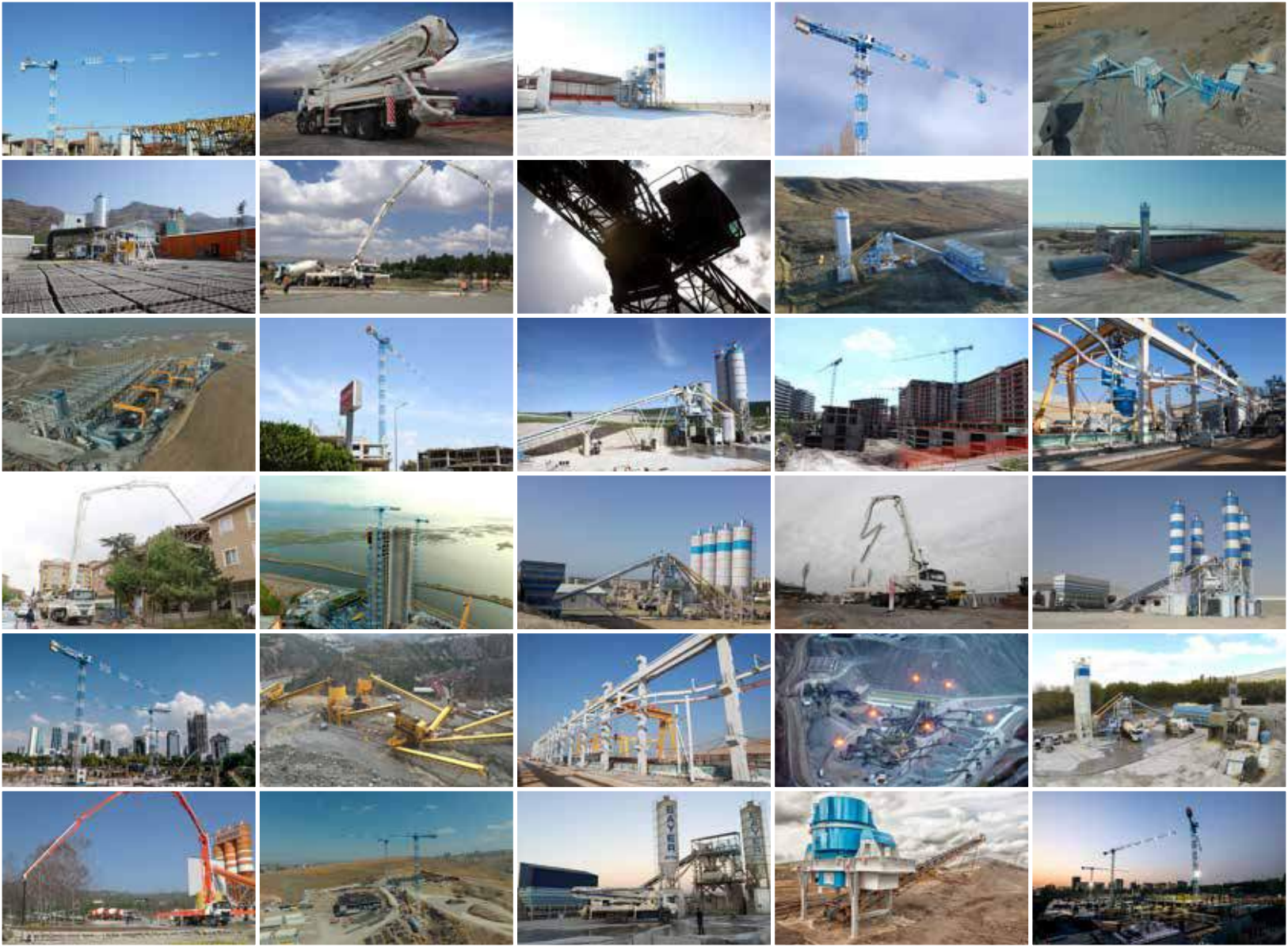



# İNŞAAT MAKİNALARI

## *CONSTRUCTION MACHINES*



# TOWER CRANES

# KULE VİNÇLERİ

Türkiye'nin ilk yerli Kule Vinç üretici Pi Makina 1982 yılından beri farklı tonajlarda Kule Vinçler imal etmektedir. Kule vinçlerimizin kaldırma kapasitesi 12 tona kadar çıkmaktadır. Yükseltme aparatı sayesinde oldukça kolay kurulum sağlayan kule vinçlerimiz özellikle büyük kapasiteli projelerde tercih edilmektedir.

Turkey's first domestic tower crane manufacturer Pi Makina has been producing Tower Cranes since 1982 with different capacities. Tower Cranes have lifting capacities between 8 and 12 tons. Tower Cranes which provide ease of erection with easy lifting element are preferred in high capacity projects.





# PI KULE 110

## PI TOWER 110

### En Uçtaki Kaldırma Kapasiteleri

Load Capacity at Jib End

Bom Uzunluğu Jib Length	24m	30m	36m	42m	48m	50m	54m	60m
Maks. Güvenli Çalışma Yüğü Max. Safety Working Load	5400	4150	3300	2650	2200	2100	1650	1150

		Hız / Speed	Güç / Power
Kaldırma / Hoisting		Maks.(Max.) 70m / min ( 5 hız / speed )	30kW / 37kW
Dönüş / Rotation		Maks. (Max.) 1 r.p.m ( 5 hız / speed )	2x5,5 kW
Araba / Trolley		0-60 m / min ( 5 hız / speed )	5,5 kW
Yürüyüş / Travelling		0-19 m / min	2 x 4 kW

	30 kW (40 HP)	37 kW (50 HP)
Toplam Güç İhtiyacı / Total Installed Power	60 kW	67 kW

# 8000 KG

Maksimum Kaldırma  
Maximum Hoisting

# 1150 KG

En uçtaki kaldırma kapasiteleri  
Load Capacity at Jib End

# 60 m

Bom Uzunluğu  
Jib Length







# PI KULE 115

## PI TOWER 115

### En Uçtaki Kaldırma Kapasiteleri / Load Capacity at Jib End

Bom Uzunluğu Jib Length	34m	37m	42m	48m	51m	54m	60m	63m
Max.Güvenli Çalışma Yüğü Max. Safety Working Load	3450	3300	2650	2200	2000	1650	1150	1000

		Hız / Speed	Güç / Power
Kaldırma / Hoisting		Maks. (Max.) 70m / min ( 5 hız / speed )	30kW / 37kW
Dönüş / Rotation		Maks. (Max) 0,8 r.p.m ( 5 hız / speed )	2 x 5,5 kW
Araba / Trolley		0-60 m / min ( 5 hız / speed )	5,5 kW
Yürüyüş / Travelling	 4,5 x 4,5 m	0-19 m / min	2 x 3 kW
	 6 x 6 m	0-15 m / min	4 x 4 kW

		30 kW (40 HP)	37 kW (50 HP)
Toplam Güç İhtiyacı / Total Installed Power	4,5 x 4,5 m	58 kW	65 kW
	6 x 6 m	68 kW	75 kW

# 8000 KG

Maksimum Kaldırma  
Maximum Hoisting

# 1000 KG

En uçtaki kaldırma kapasiteleri  
Load Capacity at Jib End

# 63 m

Bom Uzunluğu  
Jib Length





# PI KULE 140

## PI TOWER 140

### En Uçtaki Kaldırma Kapasiteleri / Load Capacity at Jib End

Bom Uzunluğu Jib Length	25m	31m	36m	42m	48m	50m	54m	60m
Max.Güvenli Çalışma Yüğü Max. Safety Working Load	6500	5100	4000	3100	2500	2300	1900	1450

	Hız / Speed	Güç / Power
Kaldırma / Hoisting	 Maks. (Max.) 70m / min ( 5 hız / speed )	37kW / 45kW
Dönüş / Rotation	 Maks. (Max) 1 r.p.m ( 5 hız / speed )	2 x 5,5 kW
Araba / Trolley	 0-60 m / min ( 5 hız / speed )	7,5 kW
Yürüyüş / Travelling	 0-19 m / min	2 x 4 kW

	37 kW (50 HP)	45 kW (60 HP)
Toplam Güç İhtiyacı / Total Installed Power	70 kW	77 kW

# 10000 KG

Maksimum Kaldırma  
Maximum Hoisting

# 1450 KG

En uçtaki kaldırma kapasiteleri  
Load Capacity at Jib End

# 60 m

Bom Uzunluğu  
Jib Length









# PI KULE 185

## PI TOWER 185

### En Uçtaki Kaldırma Kapasiteleri / Load Capacity at Jib End

Bom Uzunluğu Jib Length	25m	31m	36m	42m	48m	50m	54m	60m	66m
Max.Güvenli Çalışma Yüğü Max. Safety Working Load	7650	5950	4850	3850	3100	2800	2500	2000	1450

	Hız / Speed	Güç / Power
Kaldırma / Hoisting	 Maks. (Max.)70m / min ( 5 hız / speed )	37kW / 45kW
Dönüş / Rotation	 Maks. (Max) 0,75 r.p.m ( 5 hız / speed )	2 x 75 Nm
Araba / Trolley	 0-60 m / min ( 5 hız / speed )	7,5 kW
Yürüyüş / Travelling	 0-19 m / min	4 x 4 kW

	37 kW (50 HP)	45 kW (60 HP)
Toplam Güç İhtiyacı / Total Installed Power	78 kW	85 kW

# 10000 KG

Maksimum Kaldırma  
Maximum Hoisting

# 1450 KG

En uçtaki kaldırma kapasiteleri  
Load Capacity at Jib End

# 66 m

Bom Uzunluğu  
Jib Length





# PI KULE 225

## PI TOWER 225

### En Uçtaki Kaldırma Kapasiteleri / Load Capacity at Jib End

Bom Uzunluğu Jib Length	37m	42m	48m	54m	60m	66m	70m	75m
Max.Güvenli Çalışma Yüğü Max. Safety Working Load	9100	7000	5100	3900	3000	2300	1800	1300

		Hız / Speed	Güç / Power
Kaldırma / Hoisting		Maks. (Max.) 70m / min ( 5 hız / speed )	37kW / 45kW
Dönüş / Rotation		Maks. (Max) 0,75 r.p.m ( 5 hız / speed )	2 x 75 Nm
Araba / Trolley		0-60 m / min ( 5 hız / speed )	7,5 kW
Yürüyüş / Travelling		0-19 m / min	4 x 4 kW

55 kW (75 HP)

Toplam Güç İhtiyacı / Total Installed Power

95 kW

# 12000 KG

Maksimum Kaldırma  
Maximum Hoisting

# 1300 KG

En uçtaki kaldırma kapasiteleri  
Load Capacity at Jib End

# 75 m

Bom Uzunluğu  
Jib Length





# CONCRETE BATCHING PLANTS BETON SANTRALLERİ

Türkiye'nin ilk Beton Santrali üreticisi Pi Makina farklı ihtiyaçları karşılamak üzere saatte 30m<sup>3</sup> den 360m<sup>3</sup>'e kadar beton üretebilen farklı modellere modeller üretmektedir. Santrallerimiz özellikle hazır beton üreticileri, müteahhit firmalar, parke taşı ve prekast imalatçıları tarafından tercih edilmektedir. Beton Santrali ürün skalamız, mobil beton santrali, bantlı beton santrali, kompakt beton santrali ve prekast parke taşı beton santralinden oluşmaktadır.

Turkey's first concrete batching plants manufacturer Pi Makina manufactures these plants can produce 30 m<sup>3</sup> of concrete up to 360 m<sup>3</sup>/hour with different models for different needs of customers. Our plants especially preferred by contractor firms, ready-mixed concrete manufacturers, paving stone and precast industry. Precast concrete plant, concrete plants with conveyor, compact type plants and mobile plants are in our concrete plant product scale.

# SABİT BETON SANTRALLERİ

## STATIONARY CONCRETE BATCHING PLANTS

	30 BP	60 BP	100 BP	100 BTS	120 BTS	180 BTS	180 BTS - DX
Kapasite (m <sup>3</sup> /saat) Capacity (m <sup>3</sup> /hour)	25 - 30	55 - 60	90 - 100	90 - 100	110 - 120	170 - 180	170 - 180
Mikser Tipi Mixer Type	Planet	Planet	Planet	Twin Shaft	Twin Shaft	Twin Shaft	Twin Shaft
Mikser Motor Gücü (kW) Mixer Motor Power (kW)	18,5	37	2 x 45	2 x 37	2 x 55	2 x 90	2 x 90
Mikser Kapasitesi (Sıkıştırılmış) (l) Mixer Capacity (Compacted) (l)	500	1000	2000	2000	3000	4500	4500
Agrega Bunkerleri Göz Adedi Aggregate Bins	2 / 3 / 4 / 5	2 / 3 / 4 / 5	2 / 3 / 4 / 5	2 / 3 / 4 / 5	2 / 3 / 4 / 5	2 / 3 / 4 / 5	2 / 3 / 4 / 5
Agrega Bunkerleri Kapasitesi (m <sup>3</sup> ) Aggregate Bunker Capacity (m <sup>3</sup> )	40 - 150	40 - 150	40 - 150	40 - 150	40 - 150	40 - 150	40 - 150
Toplam Elektrik Gücü (kW) Total Motor Power (kW)	80	90	170	155	190	290	290





# MOBİL BETON SANTRALLERİ

## MOBILE CONCRETE BATCHING PLANTS

	60 MSP	60 MH	60 M	100 M	100 MS	100 MB	120 MCB
Kapasite (m <sup>3</sup> /saat) Capacity (m <sup>3</sup> /hour)	50 - 60	50 - 60	50 - 60	90 - 100	90 - 100	90 - 100	110 - 120
Mikser Tipi Mixer Type	Planet Planetary	Tek Milli Single Shaft	Tek Milli Single Shaft	Tek Milli Single Shaft	Çift Milli Twin Shaft	Çift Milli Twin Shaft	Çift Milli Twin Shaft
Mikser Motor Gücü (kW) Mixer Motor Power (kW)	37	37	37	2 x 37	2 x 37	2 x 37	2 x 55
Mikser Kap.(Sıkıştırılmış) (l) Mixer Cap. (Compacted) (l)	1000	1000	1000	2000	2000	2000	3000
Agrega Bunkerı Göz Adedi Aggregate Bins	4 Dahili Internal	4 Dahili Internal	4 Dahili Internal	4 Dahili Internal	3 / 4 / 5 Harici External	3 / 4 / 5 Harici External	3 / 4 / 5 Harici External
Agrega Bunkerı Kap. (m <sup>3</sup> ) Aggregate Bunker Cap.(m <sup>3</sup> )	40 Dahili	20 Dahili	46 Dahili	60 Dahili	60 - 120	60 - 120	60 - 120
Mikser Yükleme Mixer Loading	Bant Belt Conveyor	Bant Belt Conveyor	Bant Belt Conveyor	Bant Belt Conveyor	Kova Bucket	Bant Belt Conveyor	Bant Belt Conveyor
Çiment Silosu (m <sup>3</sup> ) Cement Silo (m <sup>3</sup> )	40 Dahili Internal	50 - 250 Harici External	50 - 250 Harici External	50 - 250 Harici External	50 - 250 Harici External	50 - 250 Harici External	50 - 250 Harici External
Toplam Elektrik Gücü (kW) Total Motor Power (kW)	100	65	70	115	125	125	160



# KOMPAKT BETON SANTRALLERİ

## COMPACT CONCRETE BATCHING PLANTS

	30 CP	60 CP	30 BSP	60 BSP	100 BSP
Kapasite (m <sup>3</sup> /saat) <i>Capacity (m<sup>3</sup>/hour)</i>	25 - 30	55 - 60	25 - 30	55 - 60	90 - 100
Mikser Tipi <i>Mixer Type</i>	Planet <i>Planetary</i>	Çift Milli <i>Twin Shaft</i>	Planet <i>Planetary</i>	Planet <i>Planetary</i>	Planet <i>Planetary</i>
Mikser Motor Gücü (kW) <i>Mixer Motor Power (kW)</i>	18,5	37	22	37	2 x 45
Mikser Kapasitesi (Sıkıştırılmış) (l) <i>Mixer Capacity (Compacted) (l)</i>	500	1000	500	1000	2000
Kova Kapasitesi (m <sup>3</sup> ) <i>Bucket Capacity (m<sup>3</sup>)</i>	0,65	1,8	1,25	2	3
Agrega Bunkerı Göz Adedi <i>Aggregate Bins</i>	4	4	2 / 3 / 4 / 5	2 / 3 / 4 / 5	2 / 3 / 4 / 5
Agrega Bunkerı Kapasitesi (m <sup>3</sup> ) <i>Aggregate Bunker Capacity (m<sup>3</sup>)</i>	28	30	40-150	40-150	40-150
Çiment Silosu (ton) <i>Cement Silo (tons)</i>	50 - 250 Harici <i>External</i>	50 - 250 Harici <i>External</i>	50 - 250 Harici <i>External</i>	50 - 250 Harici <i>External</i>	50 - 250 Harici <i>External</i>
Toplam Elektrik Gücü (kW) <i>Total Motor Power (kW)</i>	50	85	60	85	165



# PREKAST PARKE TAŐI BETON SANRALLERİ

## CONCRETE PLANTS FOR PRECAST AND PAVINGSTONE

	30 - 60 BP	30 - 100 BP
Kapasite (m <sup>3</sup> /saat) Capacity (m <sup>3</sup> /hour)	30 - 60	30 - 100
Mikser Tipi Mixer Type	Planet / Planetary	Planet / Planetary
Mikser Motor Gücü (kW) Mixer Motor Power (kW)	18,5 / 37	18,5 / 2 x 45
Mikser Kapasitesi (Sıkıştırılmış) (l) Mixer Capacity (Compacted) (l)	500 / 1000	500 / 2000
Agrega Bekletme Bunkerı Kapasitesi (l) Aggregate Holding Bunker (l)	2800	4200
Agrega Bunkerı Göz Adedi Aggregate Bins	2 / 3 / 4 / 5	2 / 3 / 4 / 5
Toplam Elektrik Gücü (kW) Total Motor Power (kW)	110	190



# PLANET BETON MİKSERLERİ

## PLANETARY CONCRETE MIXERS

		500 P	1000 P	1500 P	2000 P
Yükleme Kapasitesi (l)	Loading Capacity (l)	750	1500	2250	3000
Sıkıştırılmamış Beton Hacmi (l)	Uncompacted Concrete Volume (l)	600	1250	1800	2400
Sıkıştırılmış Beton Hacmi (l)	Compacted Concrete Volume (l)	500	1000	1500	2000
Motor Gücü (kw)	Motor Power (kw)	18,5	37	75	2 x 45
Redüktör	Gear Box	Picador	Picador	Bonfiglioli	Picador

# TEK MİLLİ BETON MİKSERLERİ

## SINGLE SHAFT CONCRETE MIXERS

		1000 S	2000 S
Yükleme Kapasitesi (l)	Loading Capacity (l)	1500	3000
Sıkıştırılmamış Beton Hacmi (l)	Uncompacted Concrete Volume (l)	1200	2400
Sıkıştırılmış Beton Hacmi (l)	Compacted Concrete Volume (l)	1000	2000
Motor Gücü (kw)	Motor Power (kw)	37	2 x 37
Redüktör	Gear Box	Dişsan	Dişsan





# ÇİFT MİLLİ BETON MİKSERLERİ

## TWIN SHAFT CONCRETE MIXERS

Çift Milli Beton Mikserleri	Twin Shaft (TS)	1000 TS	2000 TS	3000 TS	4500 TS
Yükleme Kapasitesi (l)	Loading Capacity (l)	1500	3000	4500	6750
Sıkıştırılmamış Beton Hacmi (l)	Uncompacted Concrete Volume (l)	1250	2500	3750	5400
Sıkıştırılmış Beton Hacmi (l)	Compacted Concrete Volume (l)	1000	2000	3000	4500
Motor Gücü (kw)	Motor Power (kw)	2 x 18,5	2 x 37	2 x 55	2 x 90
Redüktör	Gear Box	Bonfiglioli	Picador	Bonfiglioli	Bonfiglioli

# BETON DAĞITIM SİSTEMLERİ

## CONCRETE DELIVERY SYSTEMS

### Pi Cast 1000 (1m<sup>3</sup>) - Pi Cast 2000 (2m<sup>3</sup>)

Kova Boşaltma Tipi	Bucket Discharge Type	Altan Boşaltma / Bottom Discharge
Kova Yükselme Hızı	Bucket Lifting Speed	0.1 m/s
Kova Tahrik Sistemi (Tümü)	Bucket Drive System (All)	Hidrolik / Hydraulic
Kova Dönüş Açısı	Bucket Rotating Angle	180°

### Pi Fly 1000 (1m<sup>3</sup>) - Pi Fly 2000 (2m<sup>3</sup>)

Kova Boşaltma Tipi	Bucket Discharge Type	Dönel Boşaltma / Rotary Discharge
Kova Hızı	Bucket Speed	0.5 - 4 m/s
Kova Tahrik Sistemi (Tümü)	Bucket Drive System (All)	Hidrolik / Hydraulic
Kova Dönme Yarıçapı	Bucket Turning Radius	5 m
Tirmanma Açısı	Angle of Climb	18°
Fren Tipi	Brake Type	Disk Fren / Disc Brake

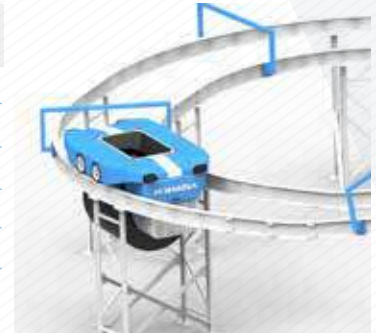





# CONCRETE PUMPS BETON POMPALARI

Farklı özelliklerde ve kapasitelerde Beton Pompası imalatı yapan Pi Makina, Türkiye'nin en eski Beton Pompası üreticilerindedir. Genellikle hazır beton üreticileri, müteahhitlik ve inşaat firmalarından oluşan müşteri portföyümüzle sadece Türkiye'de değil Dünyanın birçok ülkesinde Pi Makina kalitesi ile hizmet vermekteyiz.

Pi Makina is the oldest concrete pump manufacturer of Turkey. Our products especially preferred by contractor firms, ready-mixed concrete manufacturers, paving stone and precast industry . Pi Makina serve all over the world, not only in Turkey.

# Z BOMLU BETON POMPALARI

## CONCRETE PUMPS WITH Z BOOM TYPE

		Pİ PO K 130 30 ZX	Pİ PO K 140 40 ZX
Pompalama yüksekliği (m)	Pumping height (m)	30	39,5
Pompalama derinliği (m)	Pumping depth (m)	14,5	26
Yatay erişim (m)	Horizontal reach (m)	25,5	35,5
Kapasite (piston tarafı) (m <sup>3</sup> /s)	Capacity (piston side) (m <sup>3</sup> /h)	85	85
Kapasite (mil tarafı) (m <sup>3</sup> /s)	Capacity (rod side) (m <sup>3</sup> /h)	140	140
Maks vuruş sayısı (piston tarafı) (/dk)	Max number of stroke (piston side) (/min)	18	18
Maks vuruş sayısı (mil tarafı) (/dk)	Max number of stroke (rod side) (/min)	29	29
Ana hidrolik sistem basıncı (bar)	Main hydraulic system pressure (bar)	280	280
Bom basıncı (bar)	Boom pressure (bar)	340	350
Hidrolik rot çapı (mm)	Hydraulic rod diameter (mm)	80	80
Hidrolik piston çapı (mm)	Hydraulic piston diameter (mm)	125	125
Beton silindir çapı (mm)	Concrete cylinder diameter (mm)	230	230
Strok uzunluğu (mm)	Stroke length (mm)	1914	1914
Hazne hacmi (l)	Hopper volume (l)	540	540
Maksimum beton basıncı (bar)	Maximum concrete pressure (bar)	80	80
Beton hortumu (m)	Concrete hose (m)	5" x 4	5" x 4



# R BOMLU BETON POMPALARI

## CONCRETE PUMPS WITH R BOOM TYPE

		Pİ PO K 130 37 S	Pİ PO K 140 47
Pompalama yüksekliği (m)	Pumping height (m)	36,5	46,7
Pompalama derinliği (m)	Pumping depth (m)	24,6	32,9
Yatay erişim (m)	Horizontal reach (m)	32,5	42,6
Kapasite (piston tarafı) (m <sup>3</sup> /s)	Capacity (piston side) (m <sup>3</sup> /h)	85	85
Kapasite (mil tarafı) (m <sup>3</sup> /s)	Capacity (rod side) (m <sup>3</sup> /h)	140	140
Maks vuruş sayısı (piston tarafı) (/dk)	Max number of stroke (piston side) (/min)	18	18
Maks vuruş sayısı (mil tarafı) (/dk)	Max number of stroke (rod side) (/min)	29	29
Ana hidrolik sistem basıncı (bar)	Main hydraulic system pressure (bar)	280	280
Bom basıncı (bar)	Boom pressure (bar)	330	340
Hidrolik rot çapı (mm)	Hydraulic rod diameter (mm)	80	80
Hidrolik piston çapı (mm)	Hydraulic piston diameter (mm)	125	125
Beton silindir çapı (mm)	Concrete cylinder diameter (mm)	230	230
Strok uzunluğu (mm)	Stroke length (mm)	1914	1914
Hazne hacmi (l)	Hopper volume (l)	540	540
Maksimum beton basıncı (bar)	Maximum concrete pressure (bar)	80	80
Beton hortumu (m)	Concrete hose (m)	5" x 4	5" x 4





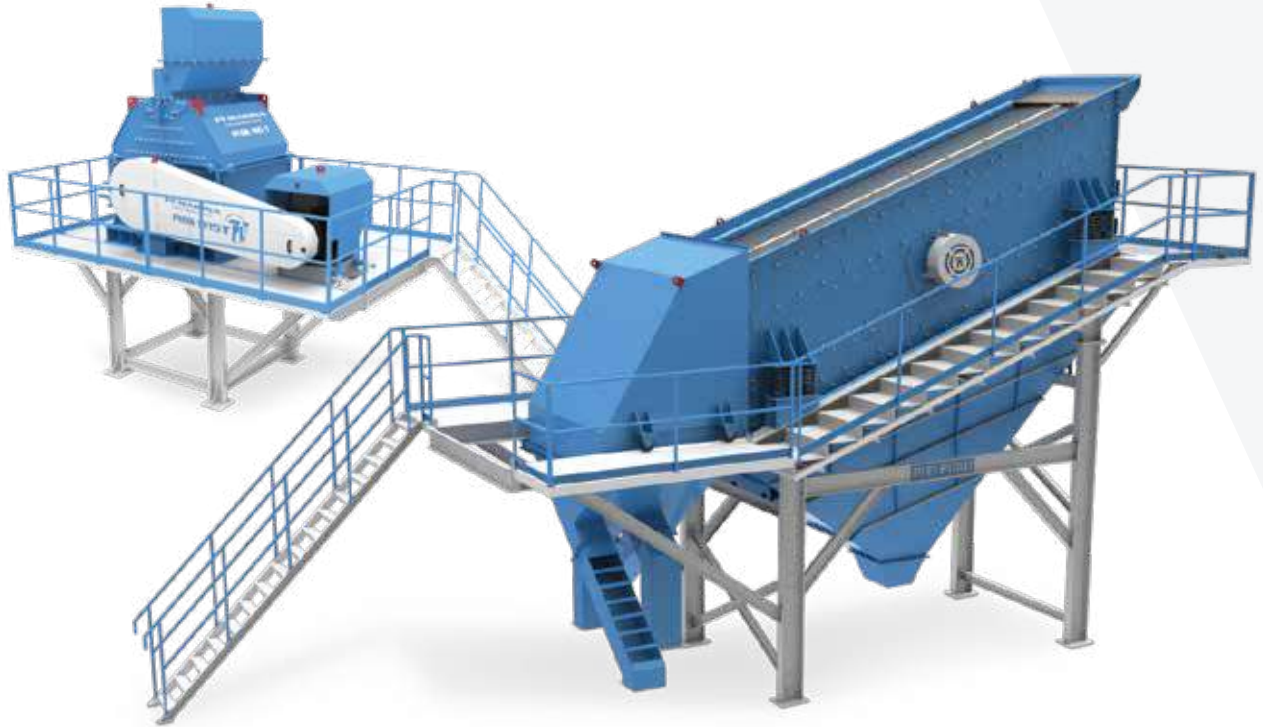

# CRUSHING AND SCREENING PLANTS KIRMA ELEME TESİSLERİ

Dünyanın sayılı, Türkiye'nin en büyük kırma eleme tesislerini kurmuş olan Pi Makina, yarım asırlık tecrübesi ile taşı uygarlığa dönüştüren makinalar üretir. Beton santralleri ve beton pompalarının yanı sıra bu tesislerde kullanılan taşları işlemek için besleyiciler, kınıclar, elekler, helezonlar ve bant konveyörler gibi her türlü kırma eleme tesisi ekipmanını sağlayarak müşterilerine komple çözüm önerileri sunuyor.

With half century of experience, Pi Makina has installed the worlds leading and Turkey's largest crushing-screening plants and continues to produce machines that converts the stone to civilization. Addition to concrete batching plants and concrete pumps, Pi Makina also provides complete professional solutios such as feeders as crushers, screens, screws and belt conveyors for the processing of stones may be used in the end-user facilities.

# TİTREŞİMLİ BESLEYİCİLER

## VIBRATING FEEDERS

		Pi Vib 150	Pi Vib 250	Pi Vib 350	Pi Vib 450
Genişlik	Width (mm)	600	900	1200	1200
Uzunluk	Length (mm)	2500	3000	4200	5000
Hazne Kapasitesi	Hopper Volume (m <sup>3</sup> )	5	15	30	35
Kapasite (ton/saat)	Capacity (ton/hour)	50 - 100	100 - 200	200 - 300	300- 400
Güç (kw/rpm)	Power Requirement (kw/rpm)	11 / 1500	22 / 1500	30 / 1500	30 / 1500
Ağırlık (kg)	Weight (kg)	6200	10400	15700	21800

# BUNKER ALTI BESLEYİCİLER

## UNDER HOPPER FEEDERS

		Pi TB 5010	Pi TB 7010	Pi TB 9010	Askılı Tip Hanging Type	Askılı Tip Hanging Type
Genişlik (mm)	Width (mm)	500	700	900	Pi ATB 6510	Pi ATB 8510
Uzunluk (mm)	Length (mm)	1000	1300	1500	1600	2000
Kapasite (ton/saat)	Capacity (ton/hour)	50 - 100	100 - 200	200 - 300	100 - 200	200 - 300
Güç (kw/rpm)	Power Requirement (kw/rpm)	1 / 1000	2 / 1000	2 / 1000	2 / 1000	2 / 1000
Ağırlık (kg)	Weight (kg)	700	1300	1500	700	900



# ÇENELİ KIRICILAR

## JAW CRUSHERS

		Primer Pi CK 600	Primer Pi CK 1000	Primer Pi CK 1100	Primer Pi CK 1250	Sekonder Pi CK 900
Anma Ölçüsü	Main Dimension (mm)	400 x 600	650 x 1000	850 x 1100	900 x 1200	300 x 910
Çıkış Ağız Açıklığı	Length (mm)	40 x 150	75 x 200	100 x 200	125 x 250	20 x 60
Kapasite (ton/saat)	Capacity (ton/hour)	20 - 60	160 - 320	170 - 370	250 - 400	30 - 50
Güç (kw/rpm)	Power Requirement (kw/rpm)	30 / 1500	90 / 1500	110 / 1500	132 / 1500	30 / 1500
Ağırlık (kg)	Weight (kg)	5400	14350	28200	34500	5150

# PRİMER DARBELİ KIRICILAR

## PRIMARY IMPACT CRUSHERS

		Pi DK 1413 P	Pi DK 1415 P
Rotor Ölçüleri	Rotor Dimensions (mm)	1400 x 1300	1400 x 1500
Maksimum Besleme	Max. Feed Size (mm)	900	1000
Kapasite (ton/saat)	Capacity (ton/hour)	200 - 300	300 - 500
Güç (kw/rpm)	Power Requirement (kw/rpm)	200 / 1500	264 / 1500
Ağırlık (kg)	Weight (kg)	26000	29000



# SEKONDER DARBELİ KIRICI

## SECONDARY IMPACT CRUSHERS

		Pi DK 906 S	Pi DK 1208 S	Pi DK 1312 S	Pi DK 1316 S
Rotor Ölçüleri (mm)	Rotor Dimensions (mm)	900 x 575	1195 x 845	1340 x 1230	1285 x 1600
Maksimum Besleme (mm)	Max. Feed Size (mm)	200	300	400	500
Kapasite (ton/saat)	Capacity (ton/hour)	50 - 100	100 - 150	150 - 250	250 - 350
Güç (kw/rpm)	Power Requirement (kw/rpm)	37 / 1500	90 / 1500	160 / 1500	250 / 1500
Ağırlık (kg)	Weight (kg)	8300	21300	27000	30000

# SEKONDER KIRICI - SD SERİSİ

## SECONDARY CRUSHERS - SD SERIES

		Pi DK 1105 SD	Pi DK 1110 SD	Pi DK 1112 SD	Pi DK 1115 SD	Pi DK 1420 SD
Rotor Ölçüleri (mm)	Rotor Dimensions (mm)	1120 x 500	1120 x 100	1120 x 1250	1120 x 1500	1400 x 2000
Maksimum Besleme (mm)	Max. Feed Size (mm)	450	450	450	450	450
Kapasite (ton/saat)	Capacity (ton/hour)	50 - 100	100 - 150	170 - 250	250 - 350	350 - 450
Güç (kw/rpm)	Power Requirement (kw/rpm)	110 / 1500	160 / 1500	200 / 1500	250 / 1500	400 / 1500
Ağırlık (kg)	Weight (kg)	10000	20000	22000	25000	40000



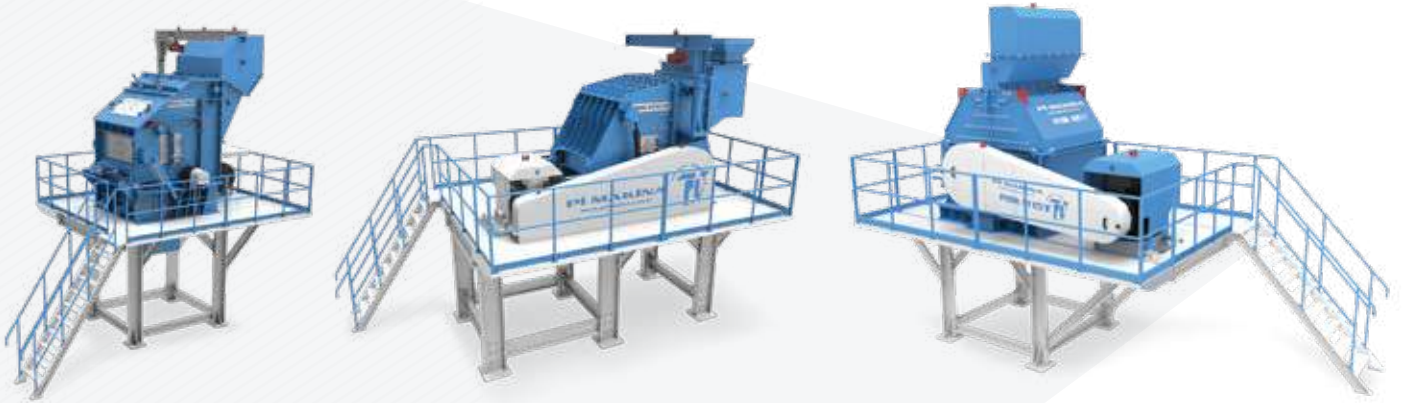

# TERSİYER DARBELİ KIRICILAR

## TERTIARY IMPACT CRUSHERS

		Pi DK 1105 T	Pi DK 1110 T	Pi DK 1115 T
Rotor Ölçüleri (mm)	Rotor Dimensions (mm)	1100 x 500	1100 x 1040	1100 x 1500
Maksimum Besleme (mm)	Max. Feed Size (mm)	150	150	150
Kapasite (ton/saat)	Capacity (ton/hour)	50 - 150	150 - 200	250 - 300
Güç (kw/rpm)	Power Requirement (kw/rpm)	110/1500	200/1500	315/1500
Ağırlık (kg)	Weight (kg)	10000	14000	19000

# DİK MİLLİ KIRICI

## VERTICAL SHAFT CRUSHER

		Pi DMK 7030	Pi DMK 9040
Rotor Çapı (mm)	Rotor Diameter (mm)	755	880
Maksimum Besleme (mm)	Max. Feed Size (mm)	40	50
Kapasite (ton/saat)	Capacity (ton/hour)	50 - 120	300 - 550
Güç (kw/rpm)	Power Requirement (kw/rpm)	70 - 100 / 1500	264 - 500 / 1500
Ağırlık (kg)	Weight (kg)	9700	13880

# KONİK KIRICI

## CONE CRUSHER

		Pi KON 100	Pi KON 200
Çene Ağız Açıklığı (css)	Closed Setting Size (css)	10-32	13-38
Maksimum Besleme (mm)	Max. Feed Size (mm)	135	185
Kapasite (ton/saat)	Capacity (ton/hour)	50 - 130	65 - 200
Güç (kw)	Power Requirement (kw)	90	132
Ağırlık (kg)	Weight (kg)	5250	8800

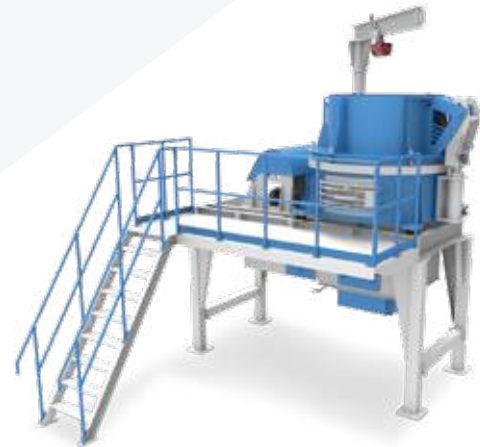

# MOBİL KIRICI

## MOBILE CRUSHER

		Pi MCUS 1208	Pi MCUS 1413
Kapasite (ton/saat)	Capacity (ton/hour)	100-150 ton/h	200-300 ton/h
Kırıcı	Crusher	Sekonder Darbeli Seconder Impact	Birincil Darbeli Primer Impact
Ağırlık (kg)	Weight (kg)	36,500	52,000
Dingil Sayısı	Axle	3	3
Güç (kW)	Power (kW)	130 (Genel / General )	276 (Genel / General )

# HİDROLİK BOMLU KIRICI

## HYDRAULIC BOOM CRUSHER

		Pi HBK 5	Pi HBK 10
Kırıcı Basıncı (bar)	Crusher Pressure (bar)	150	150
Erişim Mesafesi (m)	Operating Range (m)	5	9
Kontrol Tipi	Control Type	Mekanik / Kabolu / Kablosuz Mechanical / Wired / Wireless	Mekanik / Kabolu / Kablosuz Mechanical / Wired / Wireless
Güç (kW)	Power Requirement (kw)	15	90



# ELEKLER

## SCREENS

ELEKLER	SCREENS	Pi EL 1230	Pi EL 1640	Pi EL 1850	Pi EL 2060	Pi EL 2460
Ölçüler (mm)	Dimensions (mm)	1200 x 3000	1600 x 4000	1800 x 5000	2000 x 6000	2400 x 6000
Güç (kw/rpm)	Power Req. (kw/rpm)	7,5/ 1500	15/ 1500	8,5/ 1500	22/ 1500	30/ 1500
Ağırlık (kg) 2 Katlı	Weight (kg) 2 Decks	3000	7000	11500	-	-
Ağırlık (kg) 3 Katlı	Weight (kg) 3 Decks	4000	8000	12500	14000	20000
Ağırlık (kg) 4 Katlı	Weight (kg) 4 Decks	5200	10000	14000	18500	23500

# BANT KONVEYÖR

## BELT CONVEYOR

BANT KONVEYÖR	BELT CONVEYORS	Pi BANT 500	Pi BANT 650	Pi BANT 800	Pi BANT 1000	Pi BANT 1200
Bant Geniřliđi (mm)	Width (mm)	500	650	800	1000	1200
Kapasite (ton/saat)	Capacity (ton/hour)	200 - 100	100 - 200	200 - 350	350 - 550	550 - 750
Bant Hızı (m/sn)	Belt Speed (m/sec)	1,5	1,5	1,5	1,5	1,5
Güç (kw)	Power Requirement (kw)	3,5-5	3-11	4-15	7,5-30	11-45

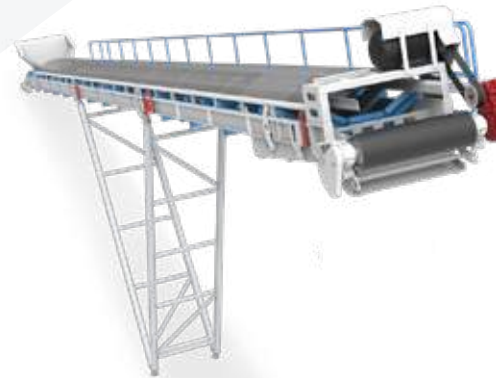

# KUM HELEZONU

## SCREW CLASSIFIER

KUM HELEZONLARI	SCREW CLASSIFIERS	Pi KUM 5060 T	Pi KUM 5060 Ç	Pi KUM 7580 Ç
Geniřlik	Width (mm)	500 x 6000	500 x 6000	750 x 8000
Kapasite (m <sup>3</sup> / saat) 0-3 mm	Capacity (m <sup>3</sup> / hour) 0-3 mm	12	25	40
Kapasite (m <sup>3</sup> / saat) 0-7 mm	Capacity (m <sup>3</sup> / hour) 0-7 mm	25	40	70
Güç (kw/devir)	Power Req. (kw/rpm)	5,5 / 1500	11 / 1500	15 / 1500
Ağırlık (kg)	Weight (kg)	1900	3500	8000

# TAMBURLU YIKAYICI

## BUCKET WASHERS

TAMBURLU YIKAYICI	BUCKET WASHERS	Pi KY 3040	Pi KY 300
Kapasite (m <sup>3</sup> / saat)	Capacity (m <sup>3</sup> / hour)	25-30	50-70
Helis Çapı	Helix Diameter	3000	3000
Geniřlik (mm)	Width (mm)	4000	7000
Devir (rpm)	Rotation (rpm)	2,5	2,5
Güç (kw)	Power (kw)	5,5	15



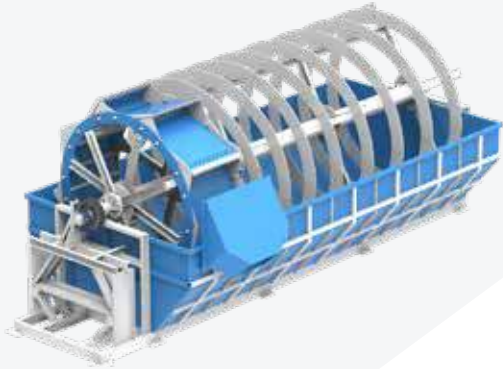

# SATIŞ VE SERVİS AĞI

SALES AND SERVICE NETWORK



**PI MAKİNA**  
www.pimakina.com.tr



**Pi Makina**  
Ana Ofisler - Main Offices  
Ankara - İstanbul - İzmir

## TÜRKİYE - TURKEY

**Adana**  
**Antalya**  
**Tokat**  
**Van**  
**Erzurum**

**Bursa**  
**Diyarbakır**  
**Sakarya**  
**Burdur**  
**İzmir**

## GLOBAL - WORLDWIDE

**Mısır - Egypt**  
**Kuveyt - Kuwait**  
**İran - Iran**  
**Umman - Oman**  
**Tunus - Tunisia**

**Cezayir - Algeria**  
**Yemen - Yemen**  
**BAE - UAE**  
**Libya - Libya**  
**Fas - Morocco**

**Rusya - Russia**  
**Suudi Arabistan - Saudi Arabia**  
**Türkmenistan - Turkmenistan**

Pİ MAKİNA

Pİ MAKİNA, bu katalogda verilen teknik değerleri ve tasarımları haber vermeksizin deęiřtirme hakkını saklı tutar.  
Pİ MAKİNA, reserves the rights to change any technical specifications and design materials in this catalogue without making any announces.



sales@pimakina.com.tr

**ANKARA OFİS - OFFICE**  
Çankaya Caddesi No: 26  
ANKARA PK : 06551  
Tel: +90 312 441 50 00

**MERKEZ OFİS - FABRİKA 1**  
**HEADQUARTERS - FACTORY 1**  
G.O.P Mah. 79/1 Sok. No:6 P.K:10-11  
06831 Gölbaşı - ANKARA  
Tel: 0 312 484 08 00

**FABRİKA 2 - FACTORY 2**  
Oğulbey Mahallesi Kümeevleri  
No:491 Gölbaşı - ANKARA  
Tel: 0312 499 50 80