



INDUSTRIAL SOLUTIONS

COMPANY PROFILE

BRIEF

HIC is an active company in in the Middle East & North Africa in production, distribution, installation and maintenance of high quality crane systems and machinery.

HIC serving a wide range of customers, including manufacturing and process industries.

HIC is a "one-stop-shop" providing supplies, services and expertise. From project inception - to execution - to completion. Thus it offers clients with just one contact and supply point for all their specific needs.

Our production line includes overhead cranes, galvanising plants and equipments, and transfer cars.

Our supply chain services include turn-key fabrication projects, production lines, industrial machines, industrial materials, metal working machines and media broadcasting solutions.

Our reliable service and competitive rates are called to deliver you unmatched customer experience.

Just provide us with the information about your needs and our specialist will follow and provide you the best solution.



OUR TEAM



The company is managed by a team of professionals that has both management expertise as well as substantial experience in the relevant sectors in which its customers are engaged in.

Through its constant efforts to meet clients' ever-changing demands, **HIC** has gained an international reputation for Integrity, professionalism, and excellence.

The company has built up a network of operations throughout most of the Middle East, North Africa and recently, Central Asia.

Consequently, it has been able to actively assist in the development of business interests for many international companies and has developed solid business relationships over the years.

Customer services all around the world,
right around the clock.





RESPONSIBLE

HIC is a by-word for safety,
confidence and
cost effectiveness.

Our responsibility to our customer.

Specialists trained by us advise you on which products are right for your application. Planning, calculation and order processing are fast.

The lasting safety and cost-effectiveness of your machinery are very important to us. Qualified and competent service specialists, professionally trained, look after your systems throughout its service life, all around the world and right around the clock.

SERVICES

WE HELP YOUR STAFF TO KEEP UP TO SPEED.

Our services extend from world-wide prompt spare parts supply to individual, system-orientated maintenance using modern diagnostic apparatus, to annual inspections to ensure national accident prevention regulations are met.

Training courses and seminars in our own training centre also form part of the extensive services offered by HIC CraneSystems.



VISION

Our vision is to be the first choice for machinery supply in our region; using our knowledge and experience to make our customers' operations safer and more productive.

MISSION

Training courses and seminars in our own training centre also form part of the extensive services offered by HIC CraneSystems.

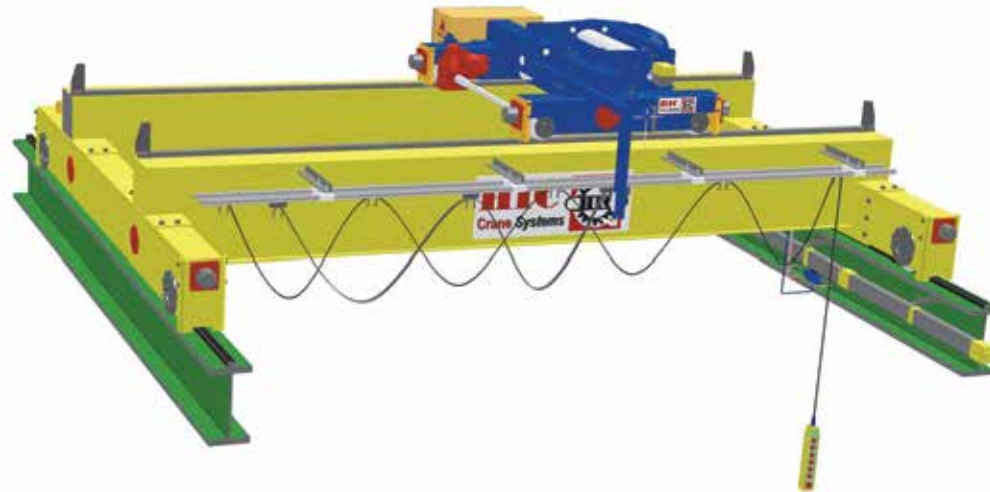

Double Girder Overhead Travelling Cranes

Capacity : Up to 200 Tons

Span : Up to 50 meters

Application : Open and coverage area material handling

Characteristics : Comprehensive standard and optional equipment to suit individual application



Single Girder Overhead Travelling Cranes

Capacity : Up to 16 Tons

Span : Up to 20 meters

Application : Open and coverage area material handling

Characteristics : Light and inexpensive solution for the light duty material handling.



Double Girder Gantry Crane

Capacity : Up to 200 Tons

Span : Up to 40 meters

Application : Open and coverage area material handling

Characteristics : Best solution for open area material handling.

Maintenance platform standart for easy operation on the crane.

Option to reach wider span.



Semi Gantry Crane

Capacity : Up to 50 Tons
Span : Up to 40 meters
Application : Open and coverage area material handling
Characteristics : Best solution for minimized area usage.

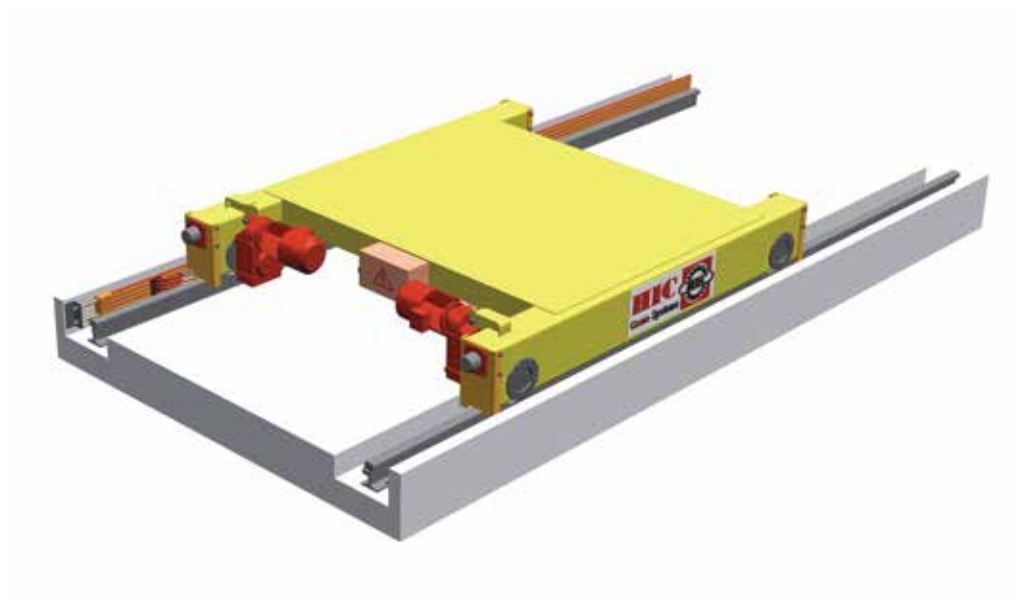

Transfer Car

Capacity : Up to 50 Tons
Application : Open and coverage area material handling
Power Supply : Busbar, cable reel and battery type.

EX-PROOF Protected Hoists

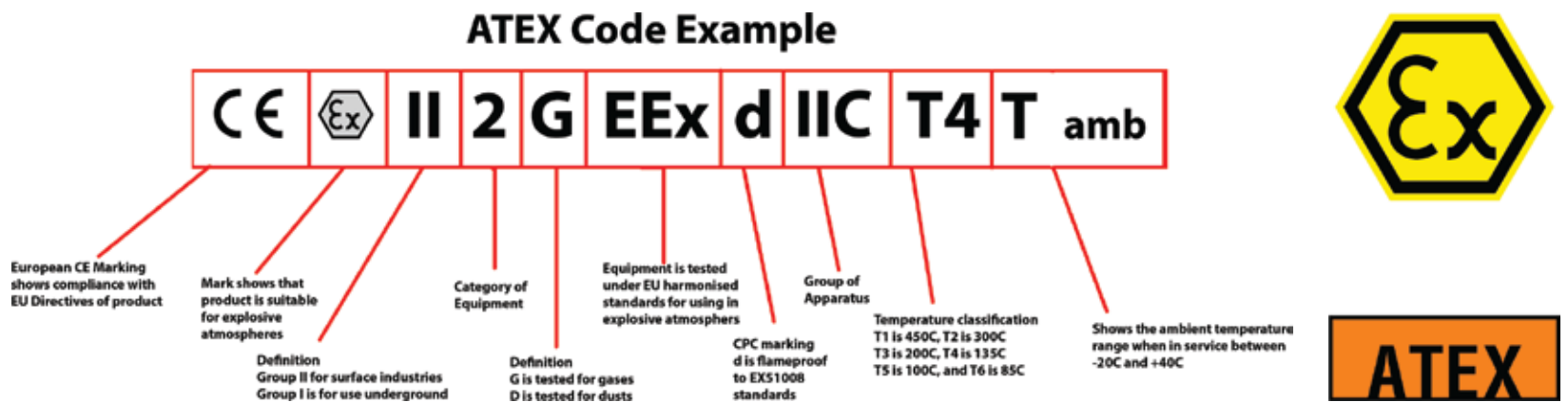

Extreme HIC CraneSystems is pioneering, dynamic and uncompromising when the safety of people and machines in areas subject to gas and explosion hazards is at stake. HIC CraneSystems occupies a prominent position in this field with experience and know-how, our own fundamental research and development, approvals from well-known test institutes.

Also, the well accepted ATEX regulations are strictly followed in our Ex-proof hoists range.

PRODUCTS

A worker in a yellow hard hat and blue uniform stands in a factory setting, looking towards the left. The background is a blurred industrial environment with various machinery and structures. A dark blue horizontal bar is positioned to the right of the word 'PRODUCTS'.

WE HELP OUR CUSTOMERS TO:

- Design
- Planning
- Analyzing
- Production
- Supply
- Assembling
- Start-up & Comissioning
- Training





INDUSTRIAL SOLUTIONS



Yeşilköy Mah. Atatürk Cad. Dünya Ticaret Merkezi No: 10/1 - 149 Bakırköy/İstanbul

Tel.: +90 536 777 04 00+90 (212) 659 79 19 **Fax:** +90 (212) 659 79 32

E-mail: info@hicindustrial.com

<http://www.hicindustrial.com>