

DIMENSIONS

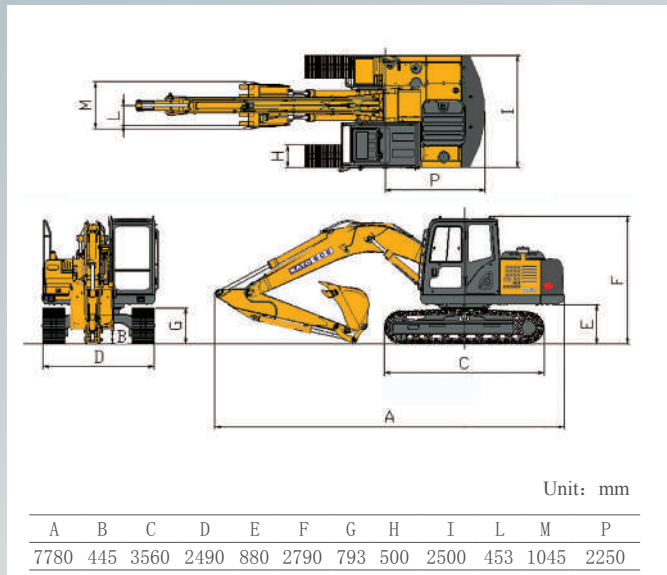

WORKING RANGE

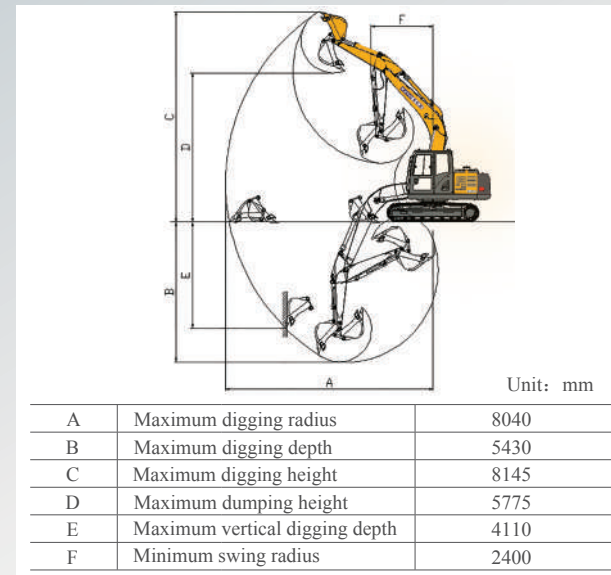

SPECIFICATION

Performance	Parameter
Operating weight	13600kg
Bucket capacity	0.53m ³
Engine model	ISUZU-4JJ1X 4 cycle intercooler turbo charged diesel engine
Number of cylinders	4
Bore× Stroke	95mm×105mm
Total displacement	2.999L
Rated output	73kW/2000min ⁻¹ (ISO 9249/SAE J1349)
Hydraulic system	
Max. discharge flow	2×130 L/min
Swing system	
Swing speed	12.0rpm

Performance	Parameter
Travel system	
Max. drawbar pull	78kN
Gradeability	70% (35°)
Travel speed	
High	5.2km/h
Low	3.0km/h
Oil tank capacity	
Fuel tank capacity	250L
Hydraulic oil tank capacity	100L
Digging force	
Bucket digging force	99kN
Arm digging force	64kN

- This booklet is only for promotion, the pictures and contents may differ from the actual objects, and the actual objects shall prevail. The contents and specifications will be subject to change without prior notice.

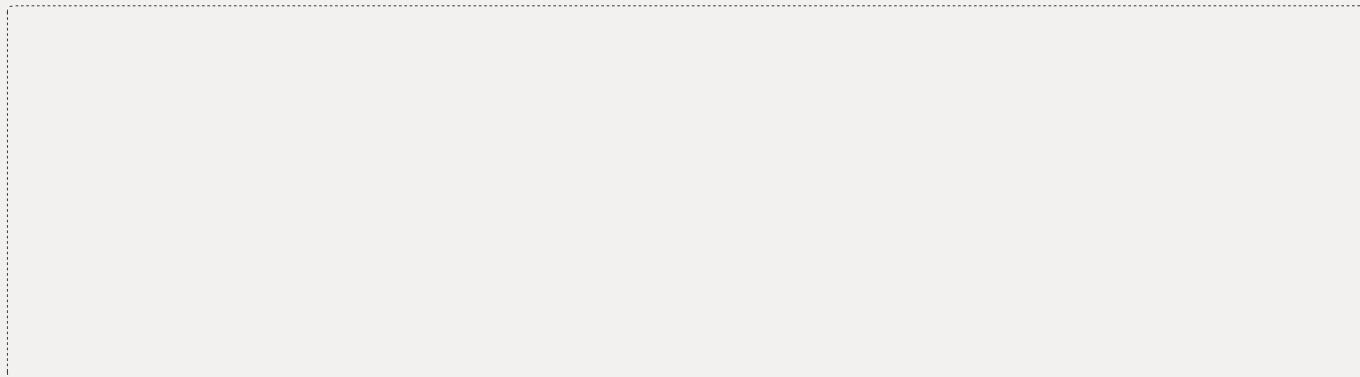

KATO SCE KATOSCE (XIAMEN) CONSTRUCTION MACHINERY CO.,LTD

Address: No.39 Huanzhu Road, North Industrial Area, Jimei District, Xiamen

Website: www.katosce.com



KATO

135NS



ECONOMY



High performance and environment-friendly Isuzu engine

The engine features low fuel consumption, low noise and strong power.

The hydraulic system provides good operability.

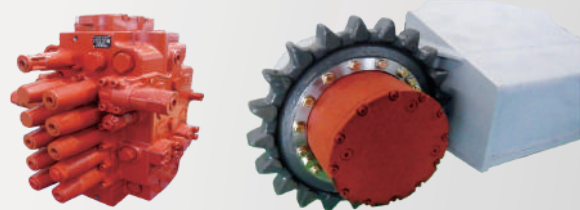

DURABILITY

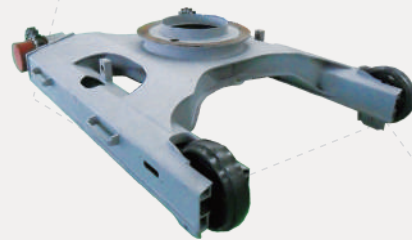

X-shaped under carriage

It enhanced the strength against twist. Mud drainage performance has increased and cleaning is now carried out with ease.



Traveling body

Sloop design center-frame and side-frame have been arranged in straight lines. Mud drainage performance is up.



Reinforced arm, boom, bucket.



COMFORTABILITY

Comfortable operating space

Ergonomic wide comfortable operating space has been designed to fit operator.



Multi point ventilation air conditioner

High capacity multi point ventilation air conditioner is standard, enabling operators to feel a multi directional air conditioning effect.

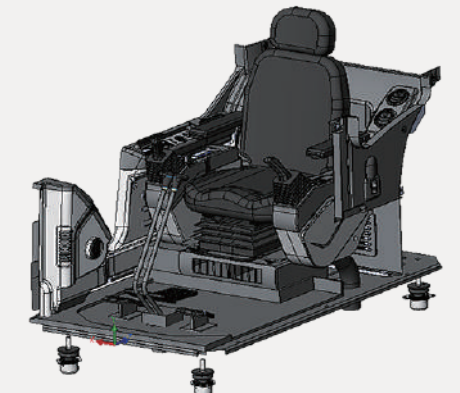

MAINTENANCE

Wide openable engine cover

The fully openable engine cover provides great access to various components. Daily maintenance such as air filter cleaning, engine oil replacement become easier.



The high capacity radiator provides superior cooling performance.



Engine error code on the display supports efficient maintenance.