

PANOVA

WINDOW & DOOR SYSTEMS

TECHNICAL CATALOG

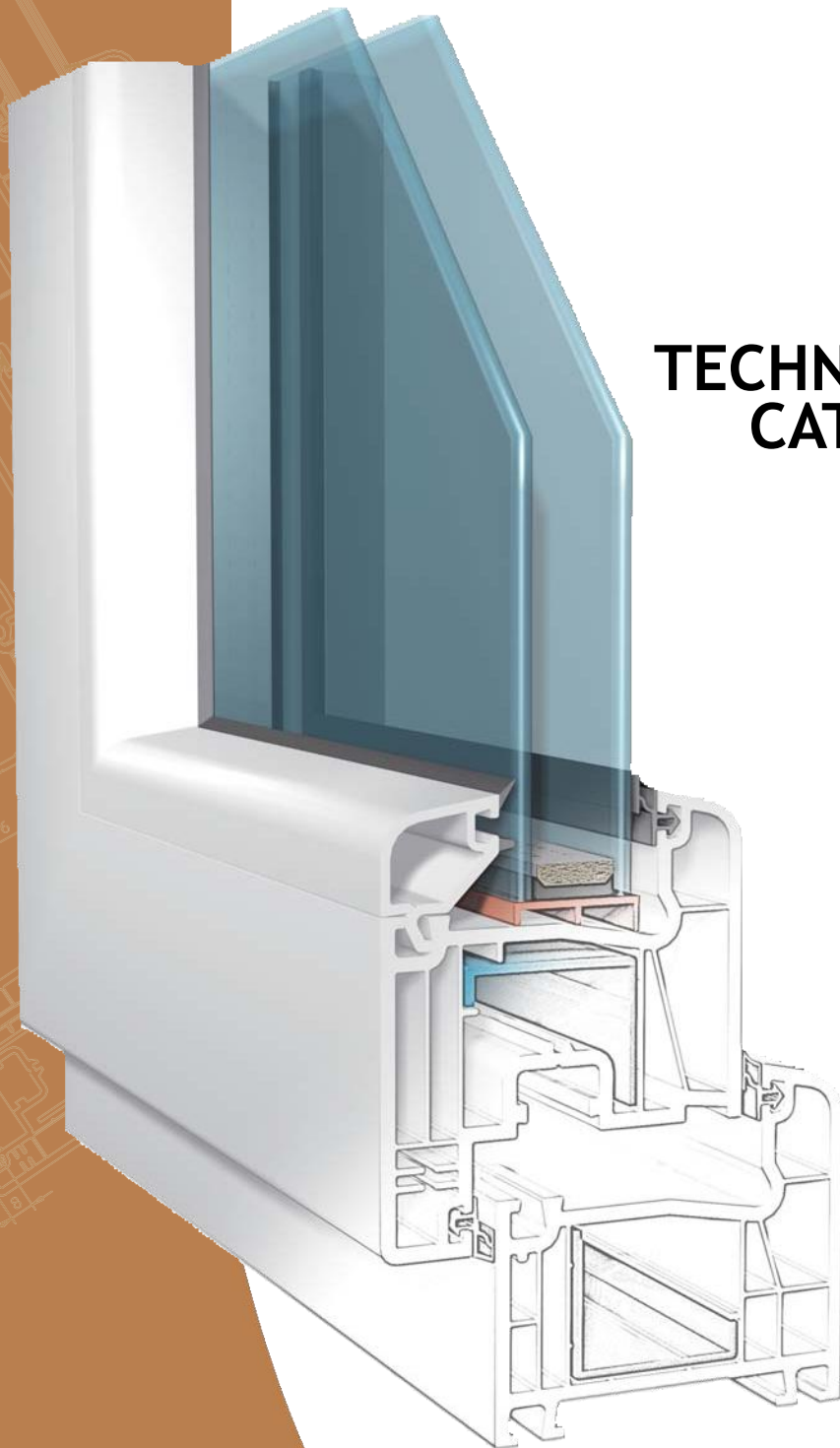

nova
70

nova
76
3 seals

nova
80

nova
85
slide

PANOVA

WINDOW & DOOR SYSTEMS

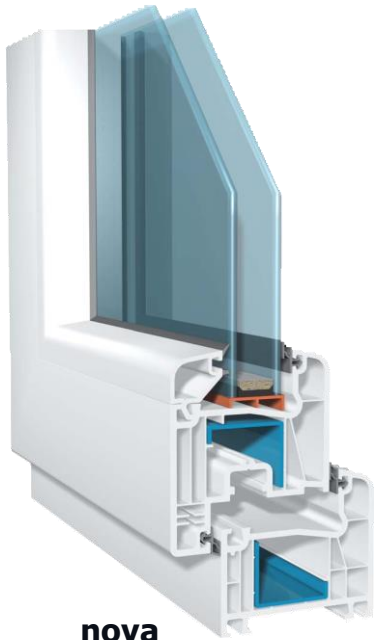

nova
70



nova
76
3 SEALS

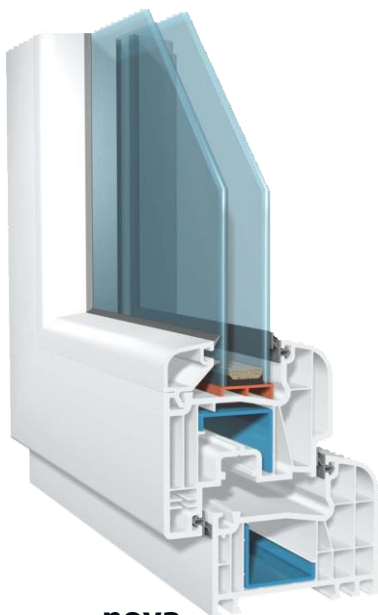

nova
80

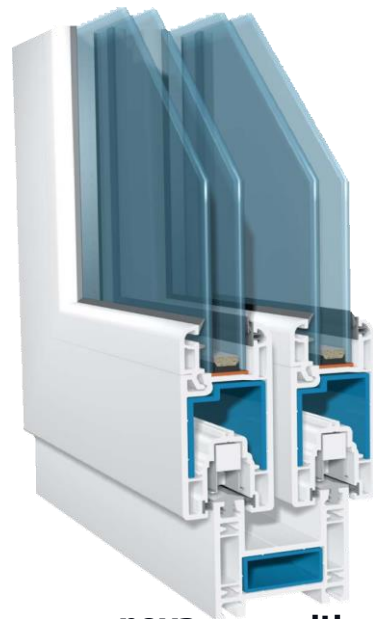

nova
85
SLIDE





NOVA 70 SERIES

The window of quality, comfort and aesthetics.

It highlights your aesthetic design with light gray seals on white profiles and black seals on colored profiles.

It adapts to your architectural designs by offering you different profile colors.

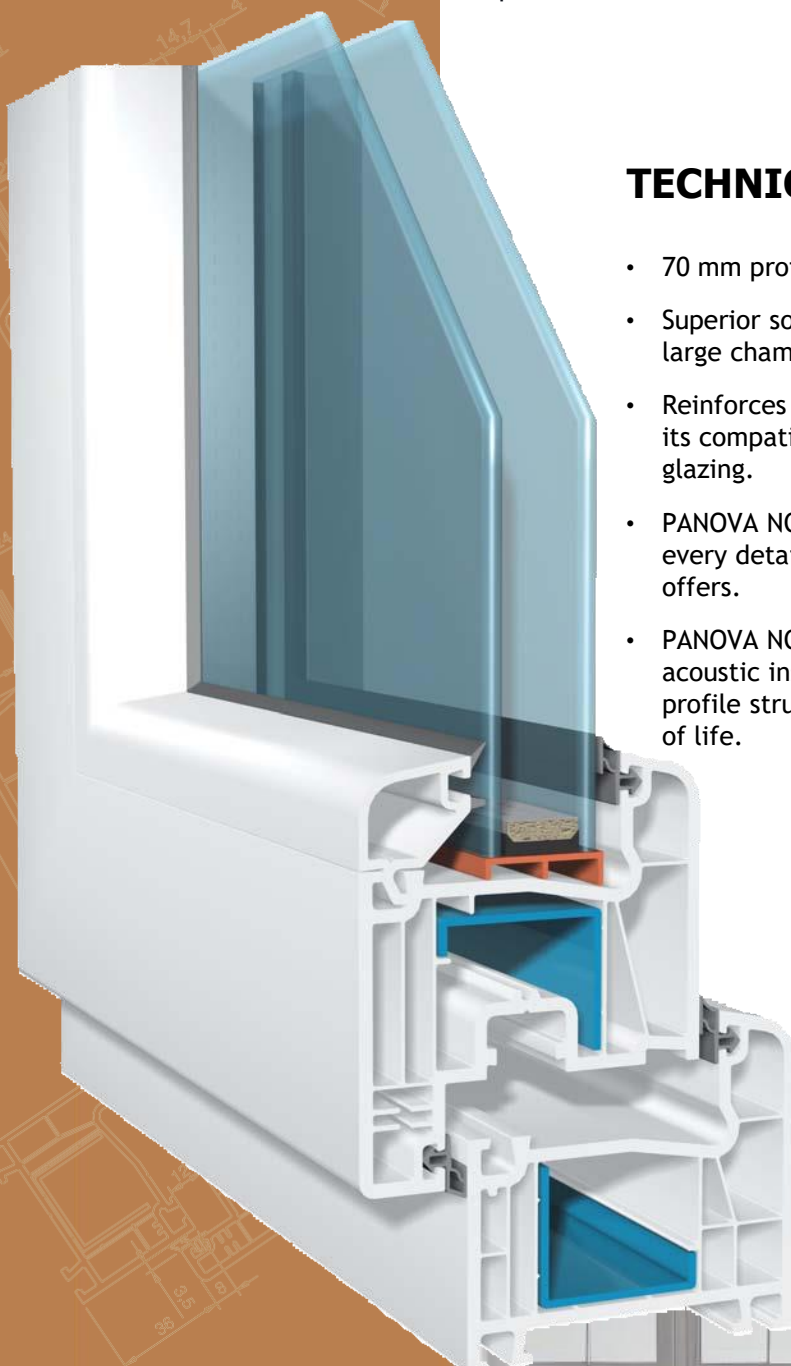

TECHNICAL SPECIFICATIONS

- 70 mm profile width.
- Superior sound and water insulation thanks to 5 large chambers and 2 seals.
- Reinforces superior thermal insulation due to its compatibility with single, double and triple glazing.
- PANOVA NOVA 70 system statically adapts to every detail thanks to the product range it offers.
- PANOVA NOVA 70 system creates maximum acoustic insulation with its multi-chamber profile structure in order to enhance comfort of life.

nova

70



NOVA 76 SERIES

The window of quality, comfort and aesthetics.

It highlights your aesthetic design with light gray seals on white profiles and black seals on colored profiles.

It adapts to your architectural designs by offering you different profile colors

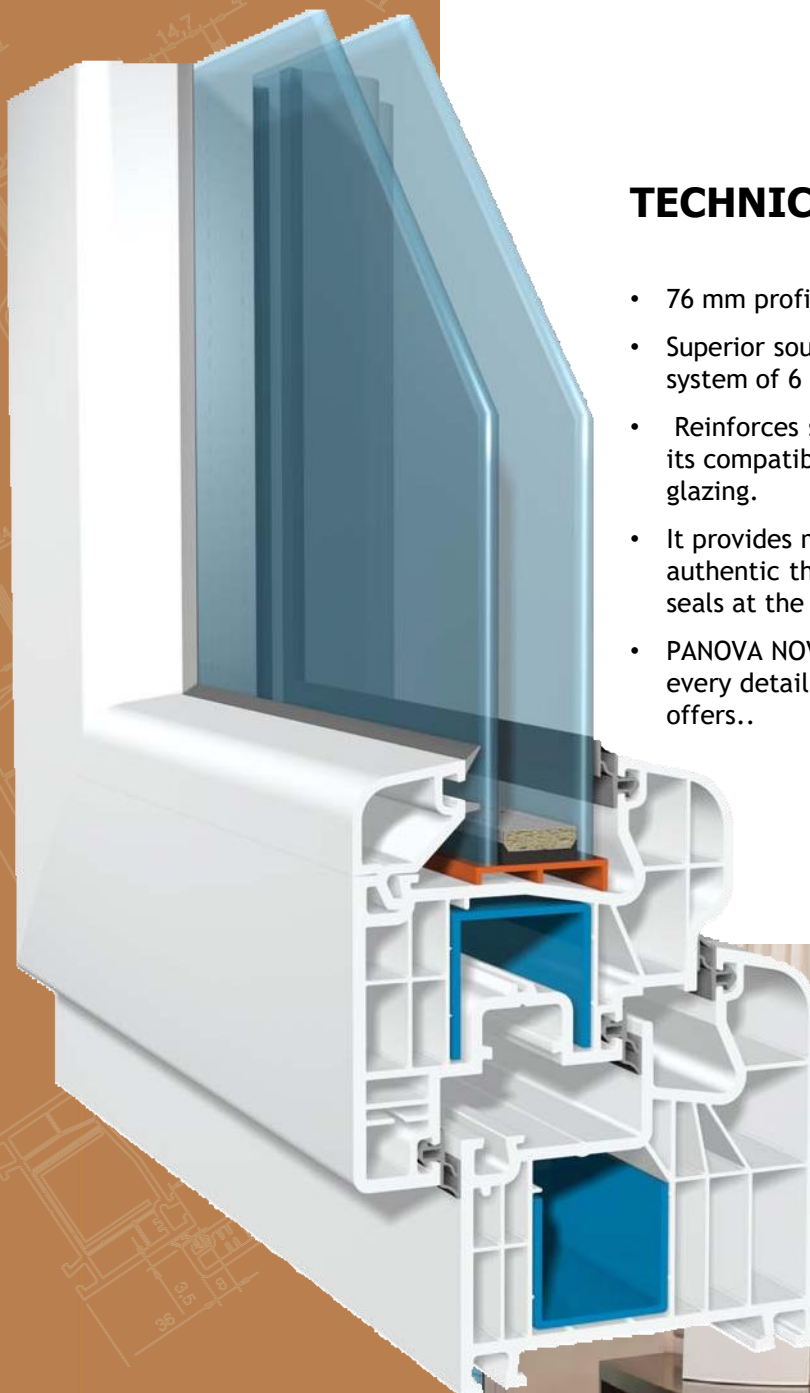

TECHNICAL SPECIFICATIONS

- 76 mm profile width.
- Superior sound and water insulation thanks to a system of 6 large chambers and 3 seals.
- Reinforces superior thermal insulation due to its compatibility with single, double and triple glazing.
- It provides maximum insulation with an authentic third seal in addition to the standard seals at the frame and casement profiles.
- PANOVA NOVA 76 system statically adapts to every detail thanks to the product range it offers..



nova

76

3 SEALS

NOVA 80 SERIES

The window of quality, comfort and aesthetics.

It highlights your aesthetic design with light gray seals on white profiles and black seals on colored profiles.

It adapts to your architectural designs by offering you different profile colors.

TECHNICAL SPECIFICATIONS

- 80 mm profile width.
- PANOVA NOVA 80 profile system features distinctive insulation with the help of its wide surface depth.
- Superior sound and water insulation thanks to 6 large chambers and 2 seals.
- Reinforces superior thermal insulation due to its compatibility with single, double and triple glazing.
- PANOVA NOVA 80 system statically adapts to every detail thanks to the product range it offers.

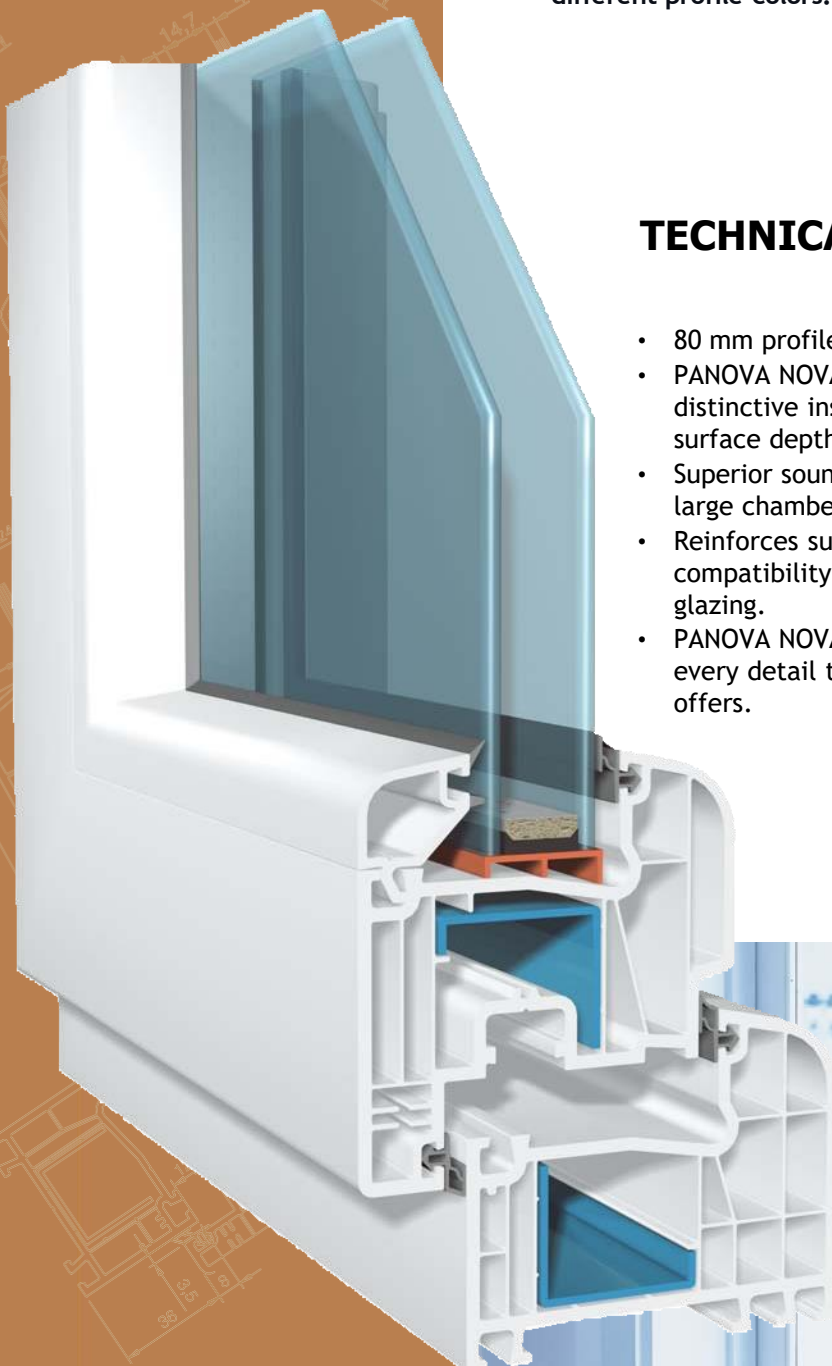

nova
80



NOVA 85 SERIES

Sliding system applications provide large and spacious spaces.

Sliding system of quality, comfort and aesthetics.

It highlights your aesthetic design with light gray seals on white profiles and black seals on colored profiles.

It adapts to your architectural designs by offering you different profile colors.

TECHNICAL SPECIFICATIONS

- 85 mm sliding frame width.
- Increases superior thermal insulation with single, double and triple glazing compatibility.
- Increases space efficiency in your spaces thanks to the wings moving horizontally.
- With its double rail system, it allows the wings to move in both directions.
- PANOVA NOVA 85 sliding system is preferred for wide openings with its superior insulation performance.

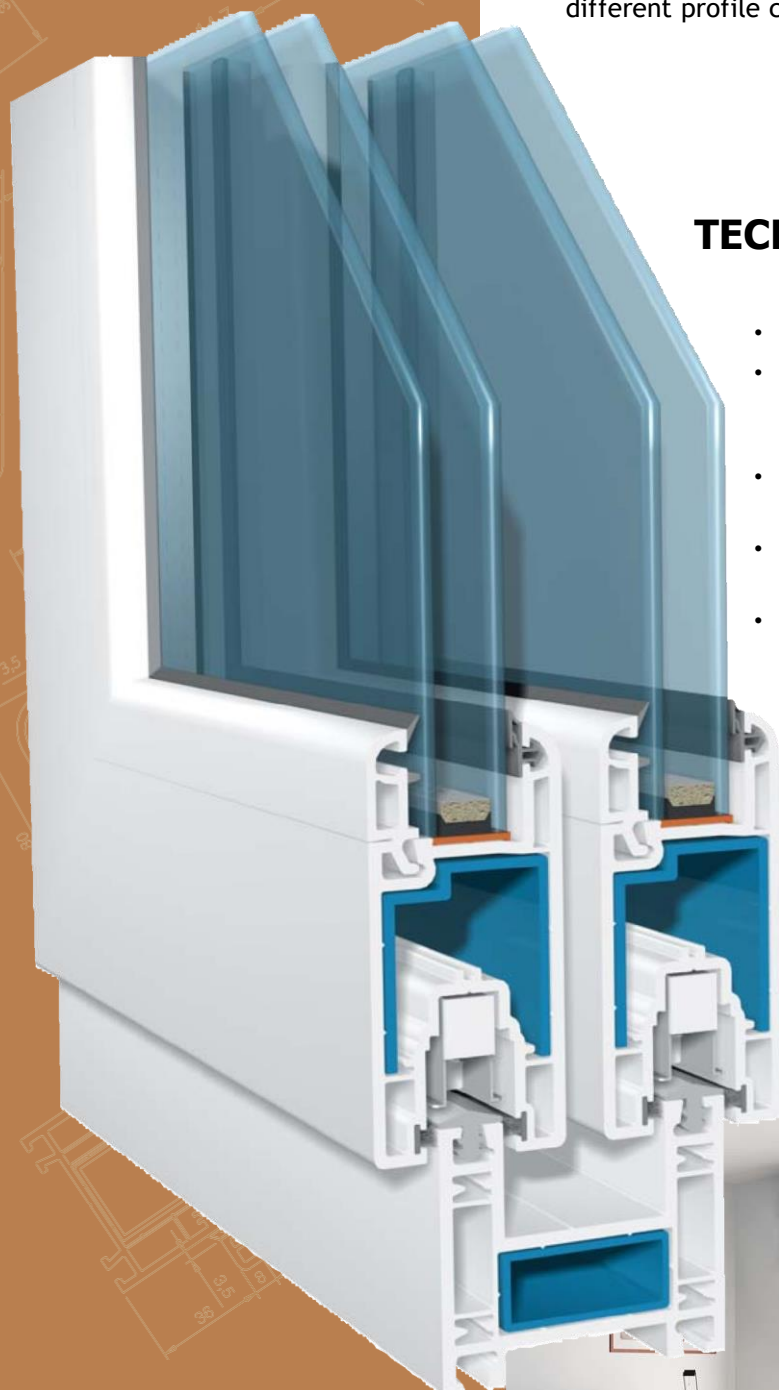

nova

85
SLIDE







Rely on it.

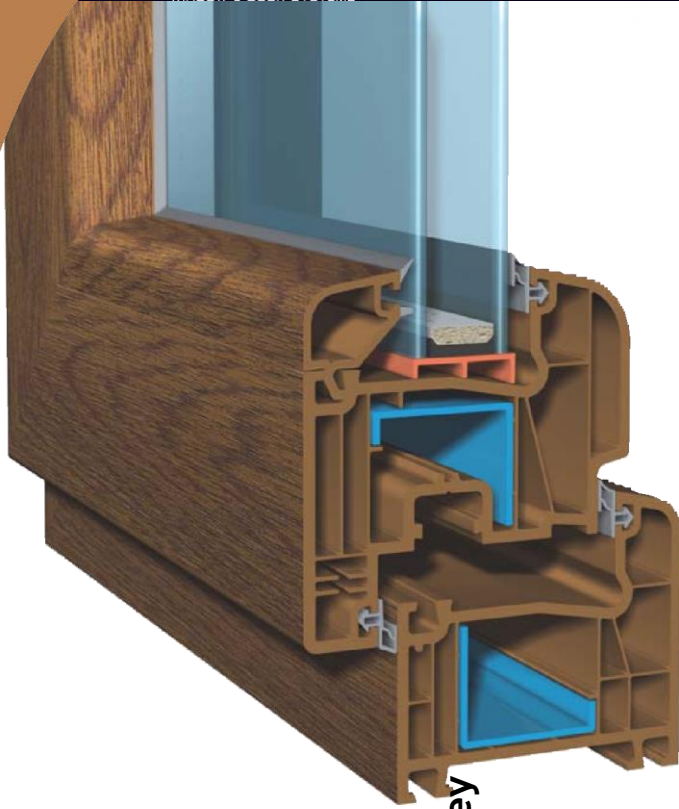

Golden Oak

Hazel

Anthracite Grey

Antique Oak

Cream

Silver

Mink

Ash Black

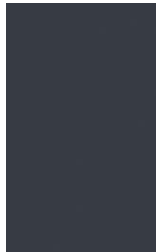

Types of Expansion





PANOVA

WINDOW & DOOR SYSTEMS

PANOVA

WINDOW & DOOR SYSTEMS



www.panova.com.tr

ÖZGÜR YAPI ELEMANLARI MERMER MADEN SAN. VE TİC. A.Ş. Organize
Sanayi Bölgesi 4. Cd. 3.Sk. No: 6
Merkez/ Afyonkarahisar

Tel: 0 272 221 18 87 Faks : 0 272 221 13 92

info@ozguryapi.com.tr www.ozguryapi.com.tr

info@panova.com.tr www.panova.com.tr