



# Universal Industrial Boilers



# About Universal boilers

- Universal Boilers was founded in 1970 by our Senior Mechanical Engineer and honorary president, the late Metin Bilgiç.
- Universal Boilers not only manufactures steam boilers or generators but also the types of boilers which produce Energy and are used in the Heat transfer process.



# About Maintenance and services

- Our company, which has ISO 9001 quality certificate, manufactures in accordance with TSE, DIN, and EN norms with its experienced engineers, technicians, and workers. Our products have the CE mark. Our company contributes to the economy of our country with exports to many countries including Asia, Europe and the Middle East in the boiler and pressure vessels sector. ÜNİVERSAL, which can produce heat devices from 100.000 kcal / h to 12.000.000 kcal / h and from 0.5 bar pressure to 30 bar pressure, exports 50% of its production. It offers strong sales and after-sales service with its dealer and service network.



# Our philosophy



## Mission

**Universal Boilers has added value in the production of manufacturers in Turkey and Worldwide using steam energy.**



## Vision

- **To maintain our growth trend above the sector average**
- **Zeroed industrial accidents**
- **Providing equivalent value sale and service to average sector**
- **Self-improving staff who know the benefit to be obtained from the company is proportional added value.**



## Values

- **Honesty and a fair shake.**
- **Customer satisfaction.**
- **Civil respect.**
- **Innovativeness.**
- **Team work.**
- **Leadership.**
- **Productivity.**
- **Secrecy.**
- **« Open Door » Policy.**

# Organizational Governance and Compliance Framework

---

## Quality Policy

- Find Perfectness in Service.
  - Show an approach focusing on customer.
  - Create the difference with our Works.
  - Use advanced technology.
  - Manage sources in the best manner.
  - Act with Social responsibility awareness.
  - Increase activity and efficiency.
- 

---

## Security Policy

Safety is the top priority of all reaches of Universal Boiler Company. It is an indispensable and uncompromising part of our company's corporate values. It is of great importance that the attachment to safety at all levels of Universal Boiler is kept at best practices and standards in the sector.

---

## Occupational health safety

- Obey the rules.
  - Think about environment and human when growing.
  - Minimize the damage and disturbance.
  - Employee engagement.
  - Manage the risks.
  - Continuous improvement.
-

# Our products

—  
**SCOTCH TYPE  
STEAM BOILER**

—  
**PRESSURISED  
COMBUSTION  
TYPE STEAM  
BOILER**

—  
**HIGH  
TEMPERATURE  
OIL BOILER**

—  
**HOT WATER  
BOILER**

—  
**HOT AIR BOILER**

—  
**DIRECT HOT  
WATER  
GENERATING UNIT**

# Our products



**STEAM  
GENERATORS**



**HEAT RECOVERY  
SYSTEMS FROM  
FLUE GAS**



**FLASH STEAM  
UNITS**



**INDIRECT STEAM  
GENERATORS**



**MODERN  
DEARATORS**



**DEARATORS**

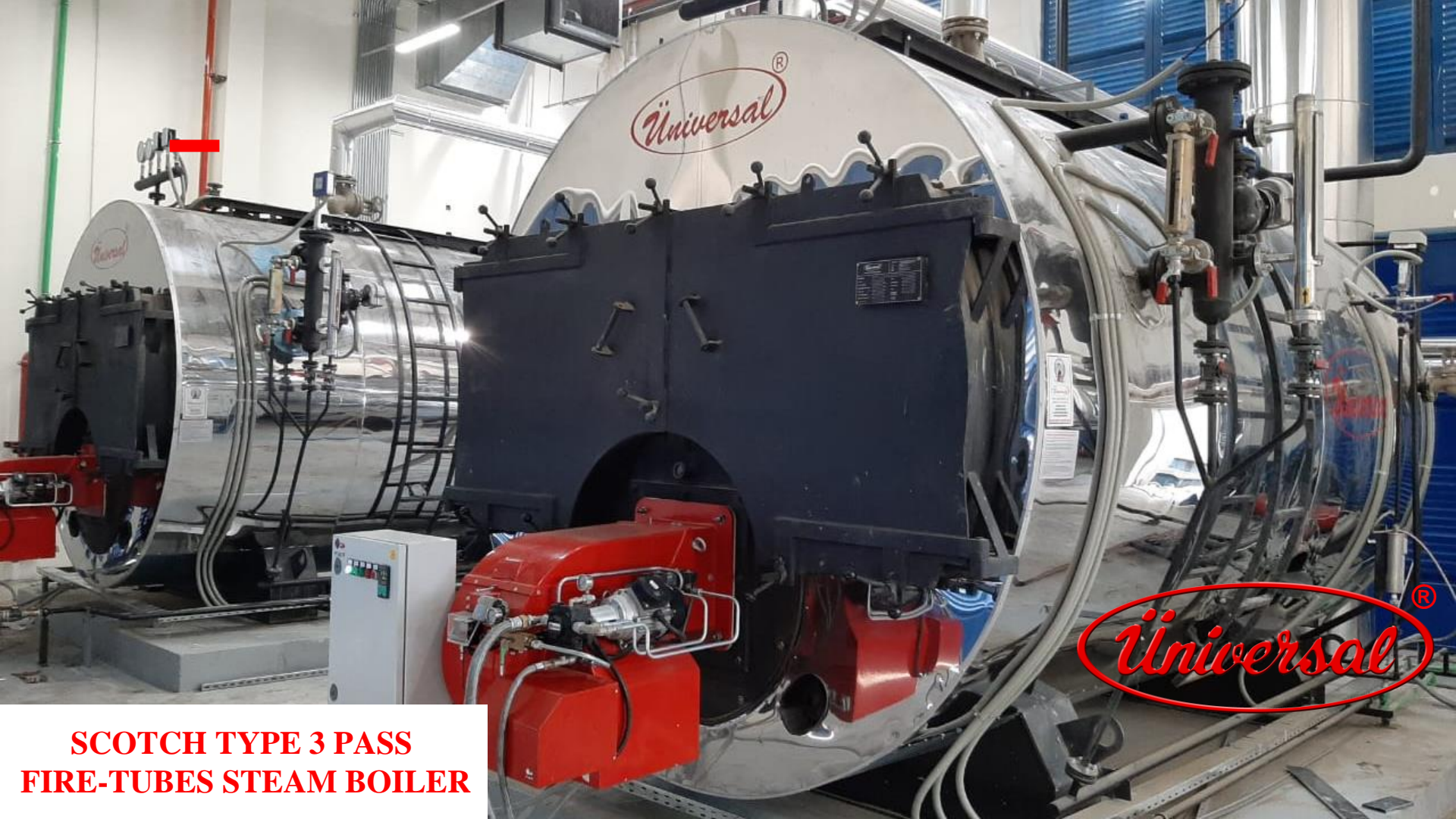

**SCOTCH TYPE 3 PASS  
FIRE-TUBES STEAM BOILER**



# Boiler room flow diagram

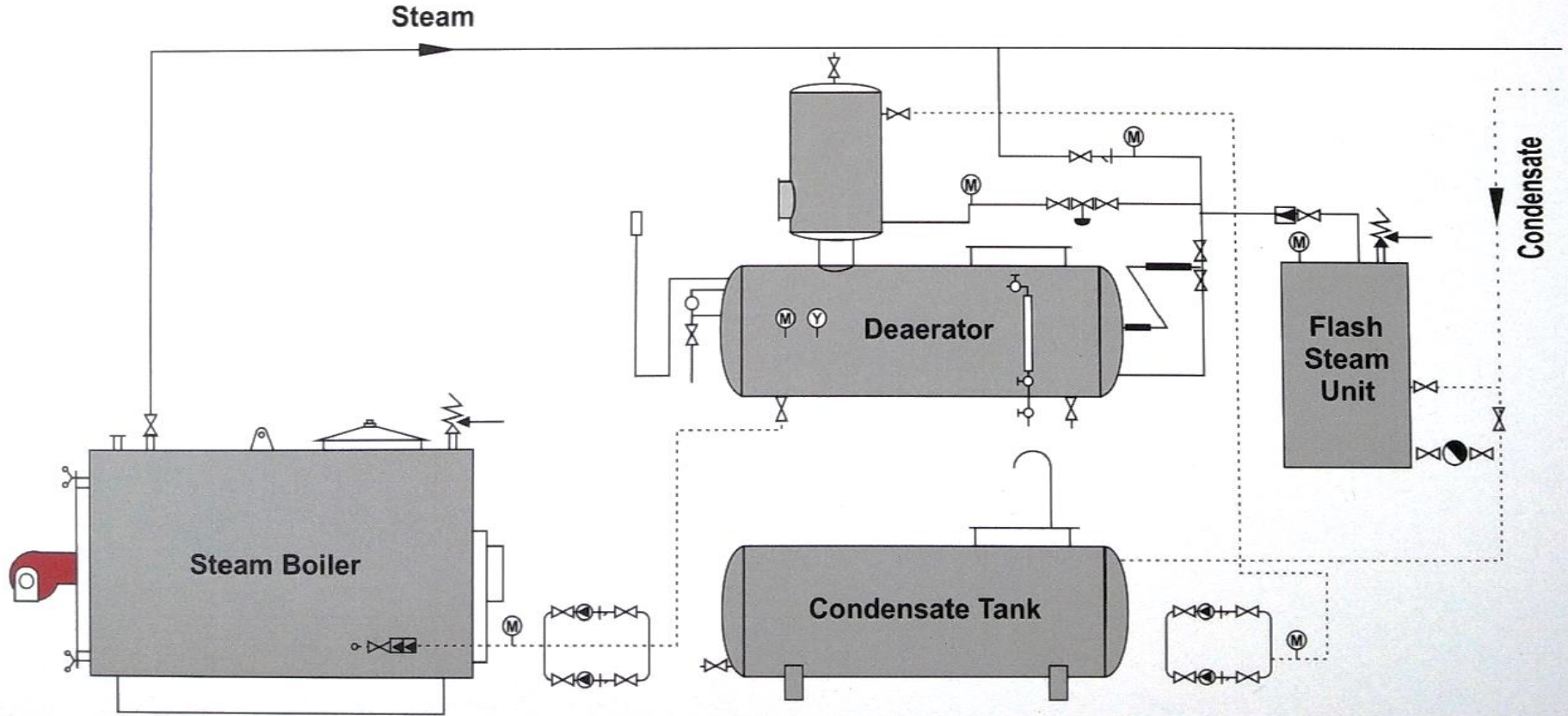



**Thermal Deaerator- ÜDP**



# **FIRE-TUBES TYPE STEAM GENERATOR**

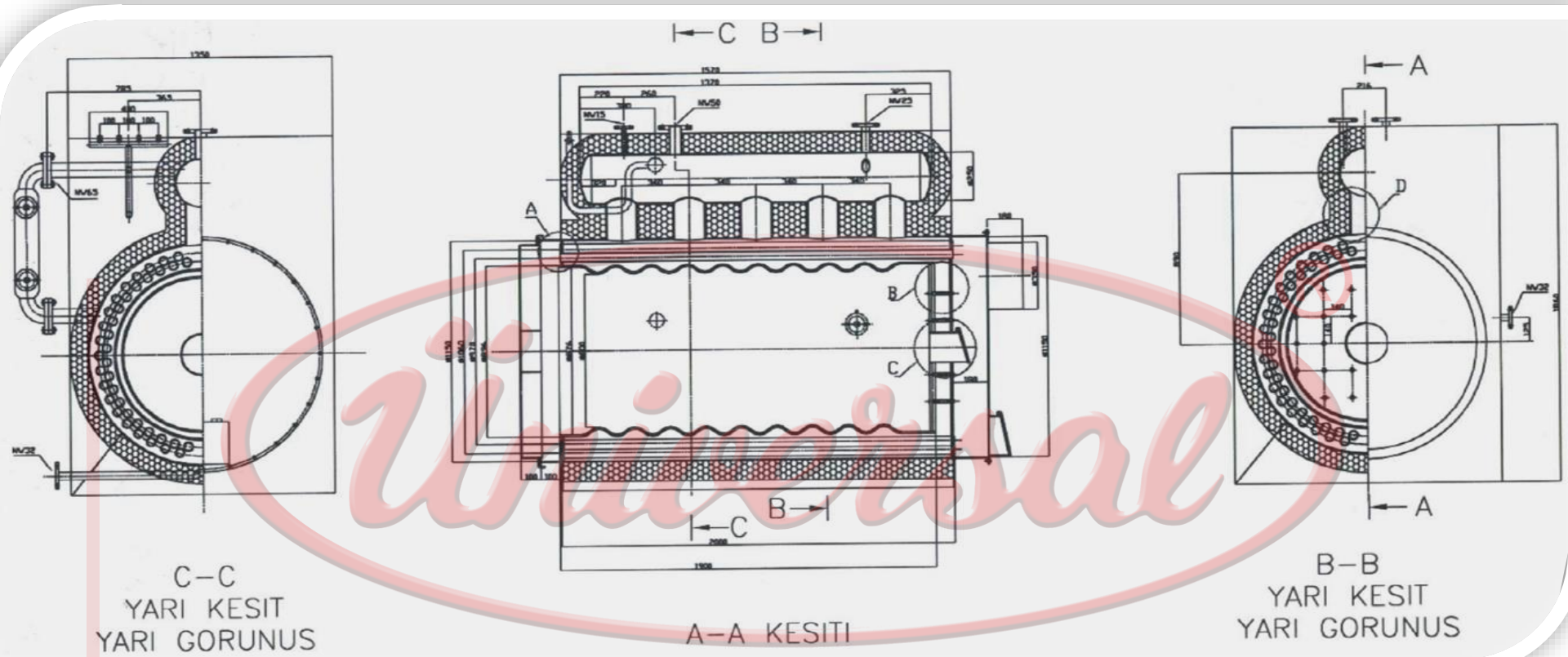

# FIRE-TUBES TYPE STEAM GENERATOR

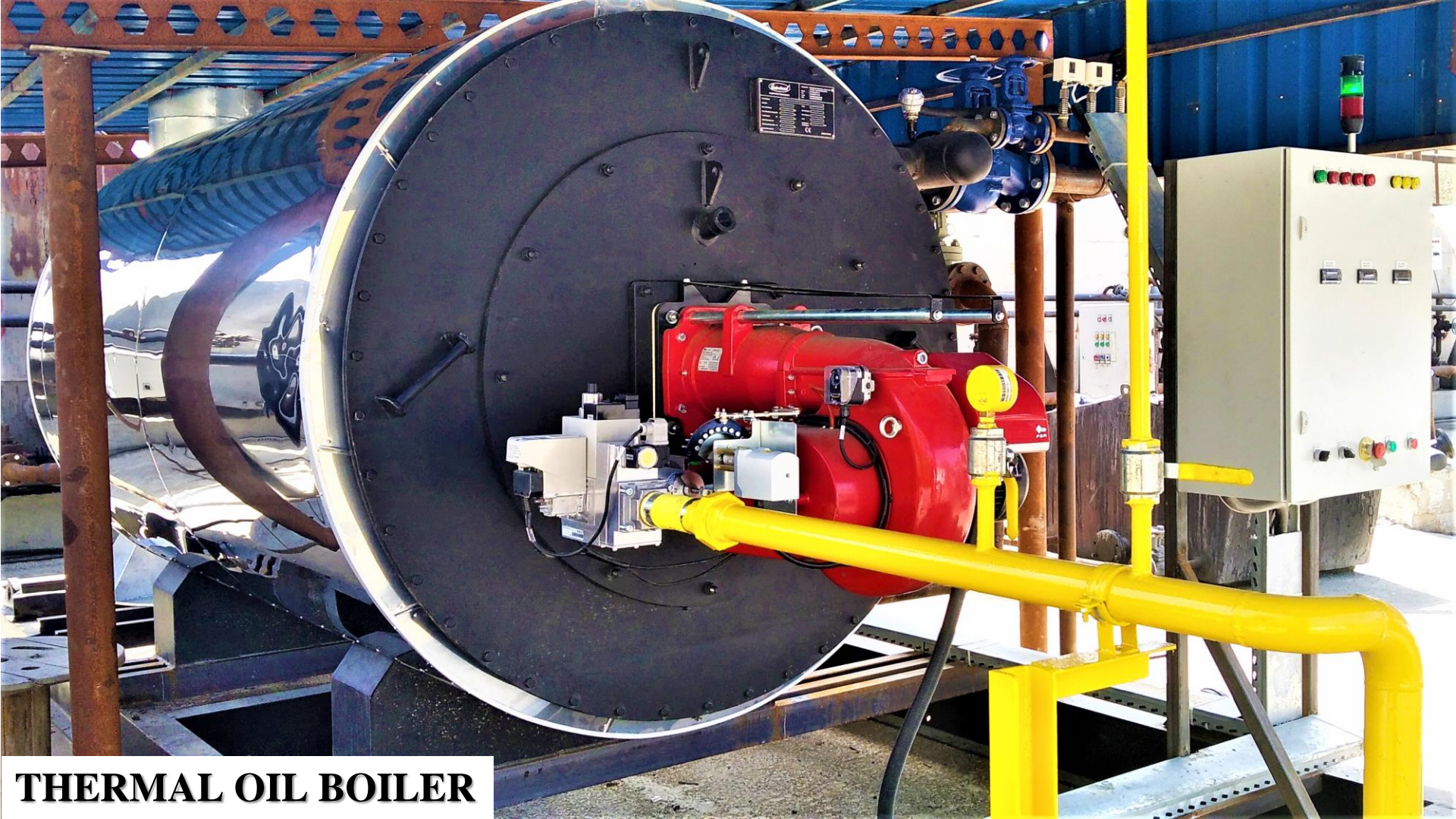

**THERMAL OIL BOILER**

# Boiler room flow diagram

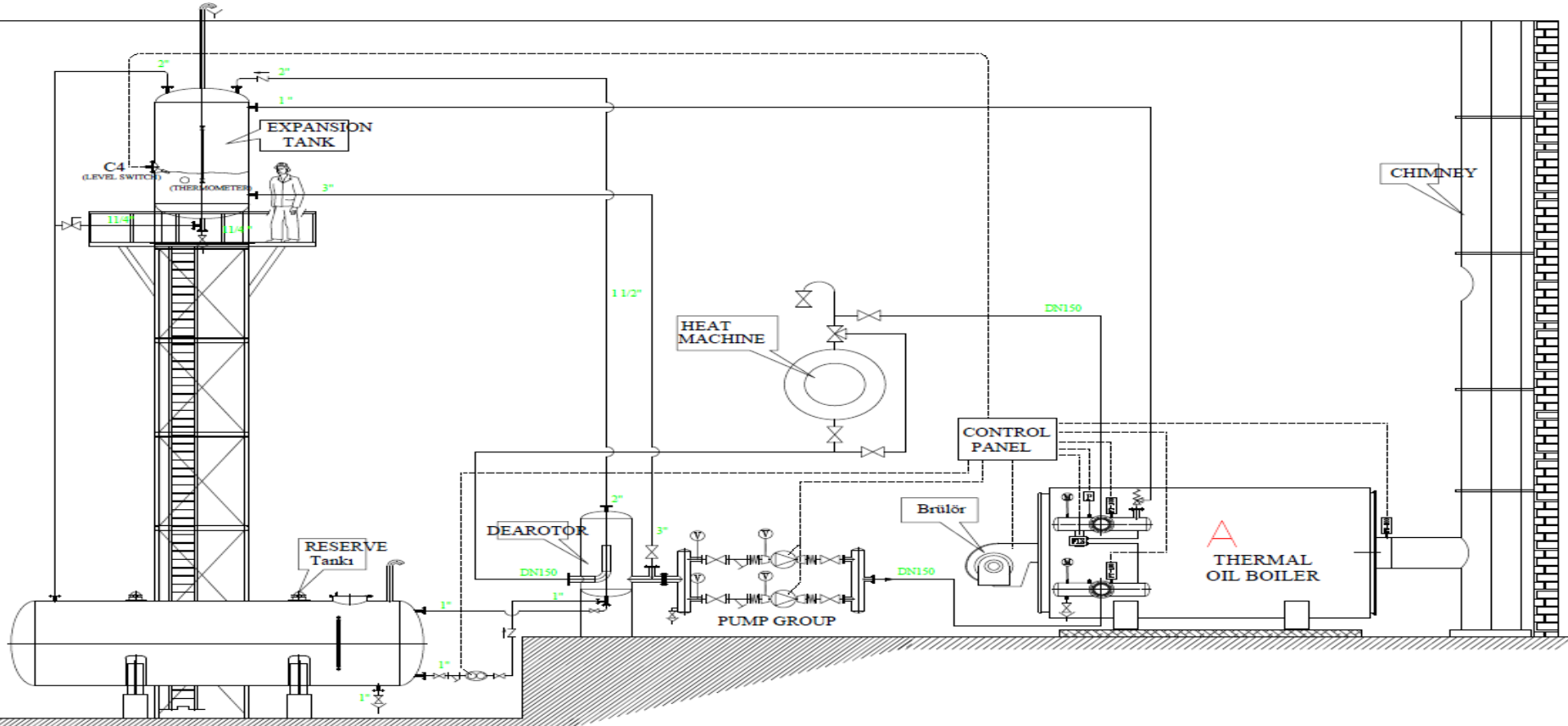

# SOLID FUEL SCOTCH TYPE 3 PASS STEAM BOILER



# Solid fuel steam boiler







# Electrical steam generator

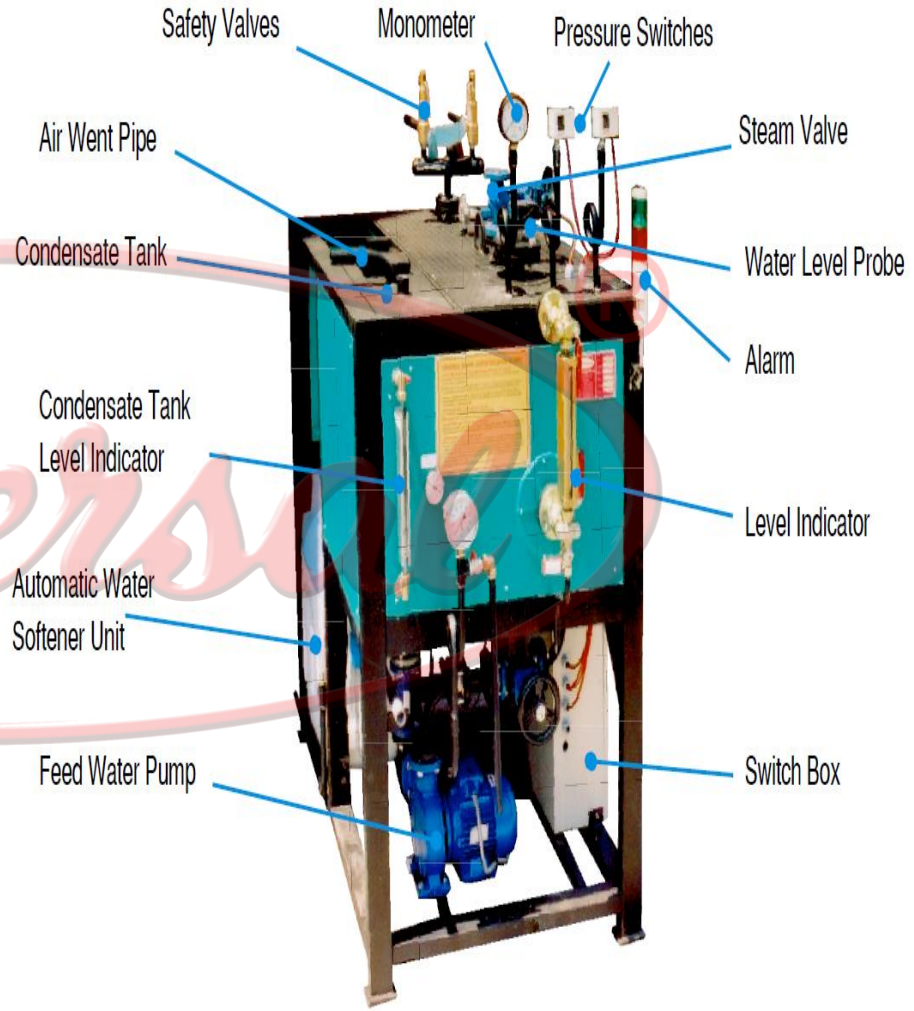
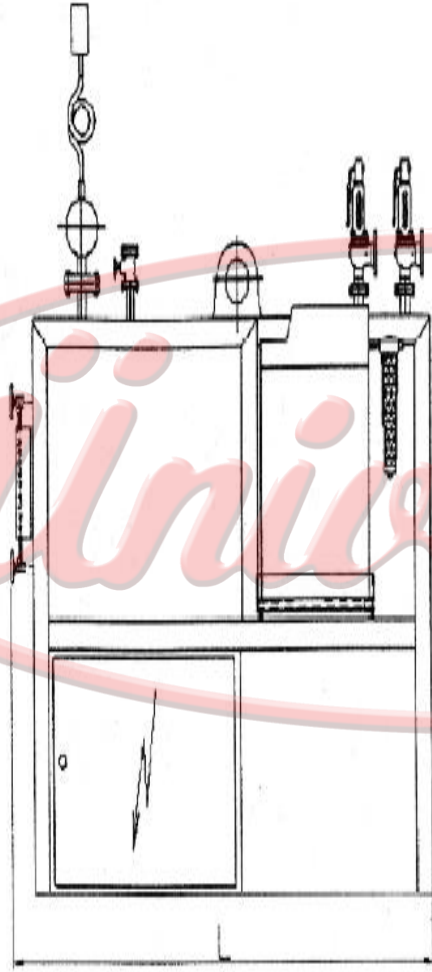
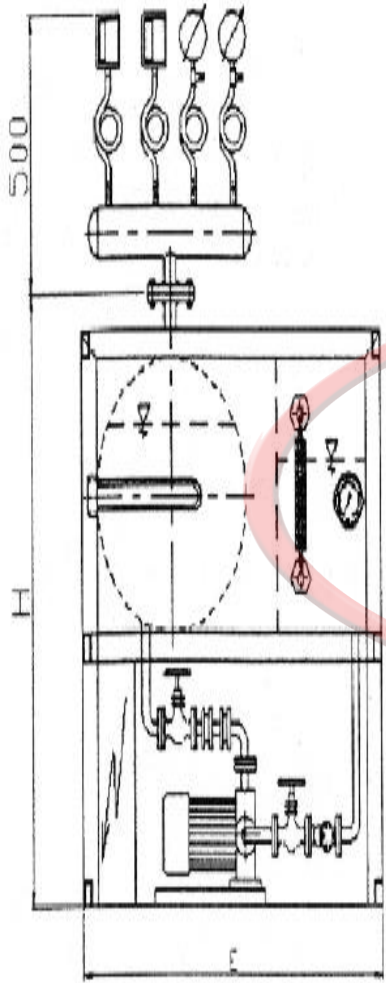

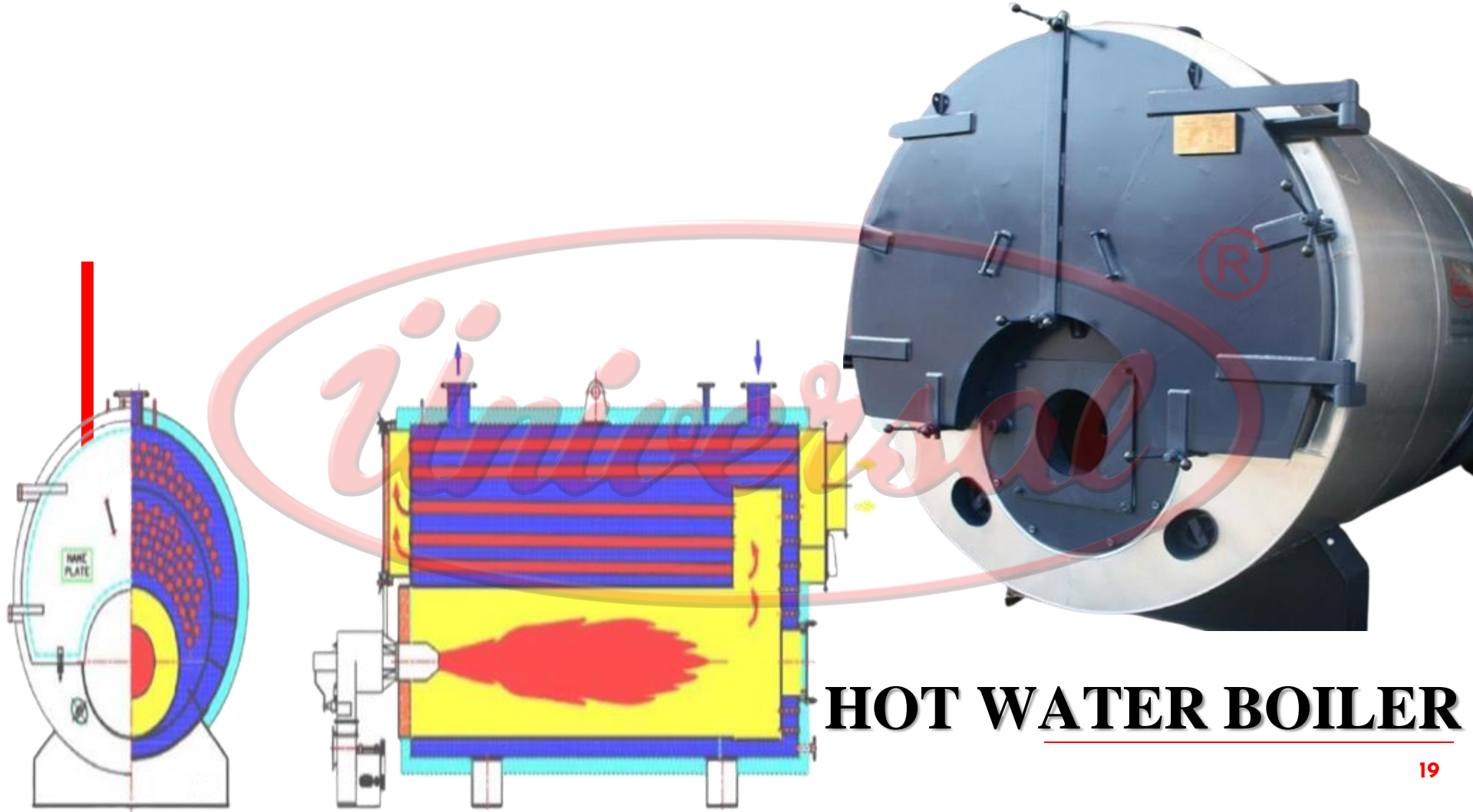

# **HOT WATER BOILER**

# Boiler room flow diagram

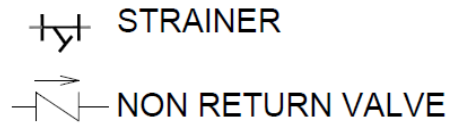
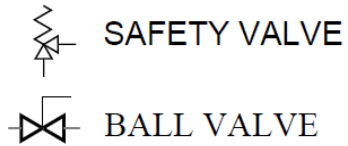
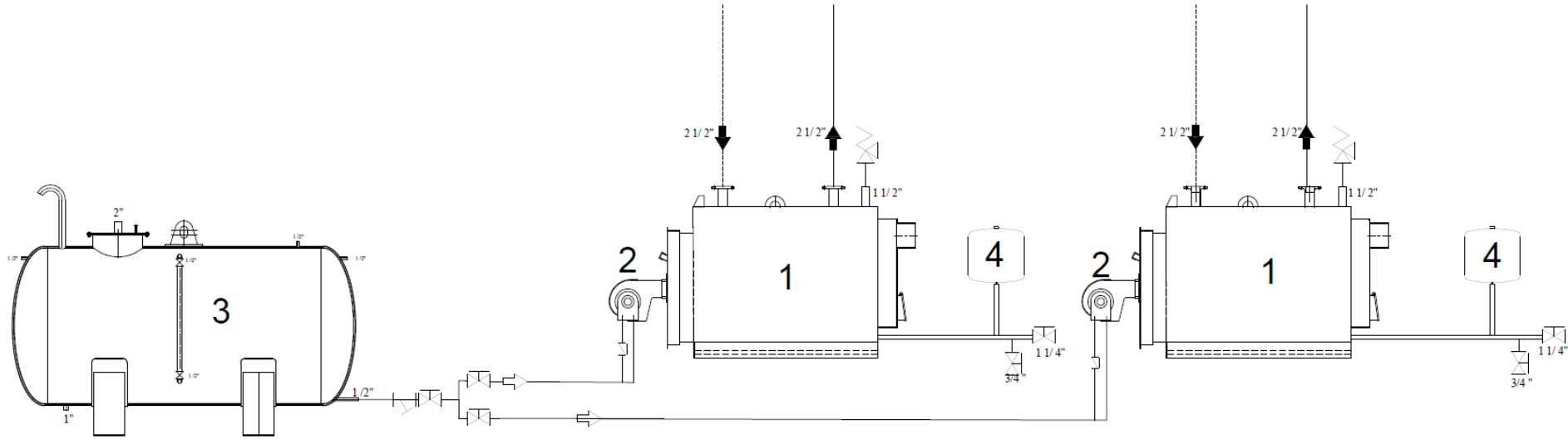

1. Hot Water Boiler
2. Burner
3. Diesel Double Skin Fuel Tank
4. Expansion tank



**Universal**®

**Oil and gas fired, fire-tubes  
type hot water boiler**



*Universal*



# **Electrical Hot Water Boiler**

---



## **3 Pass Scotch Type Steam Boiler – SB**



**VERTICAL TYPE  
SPIRAL TUBE STEAM  
GENERATOR**



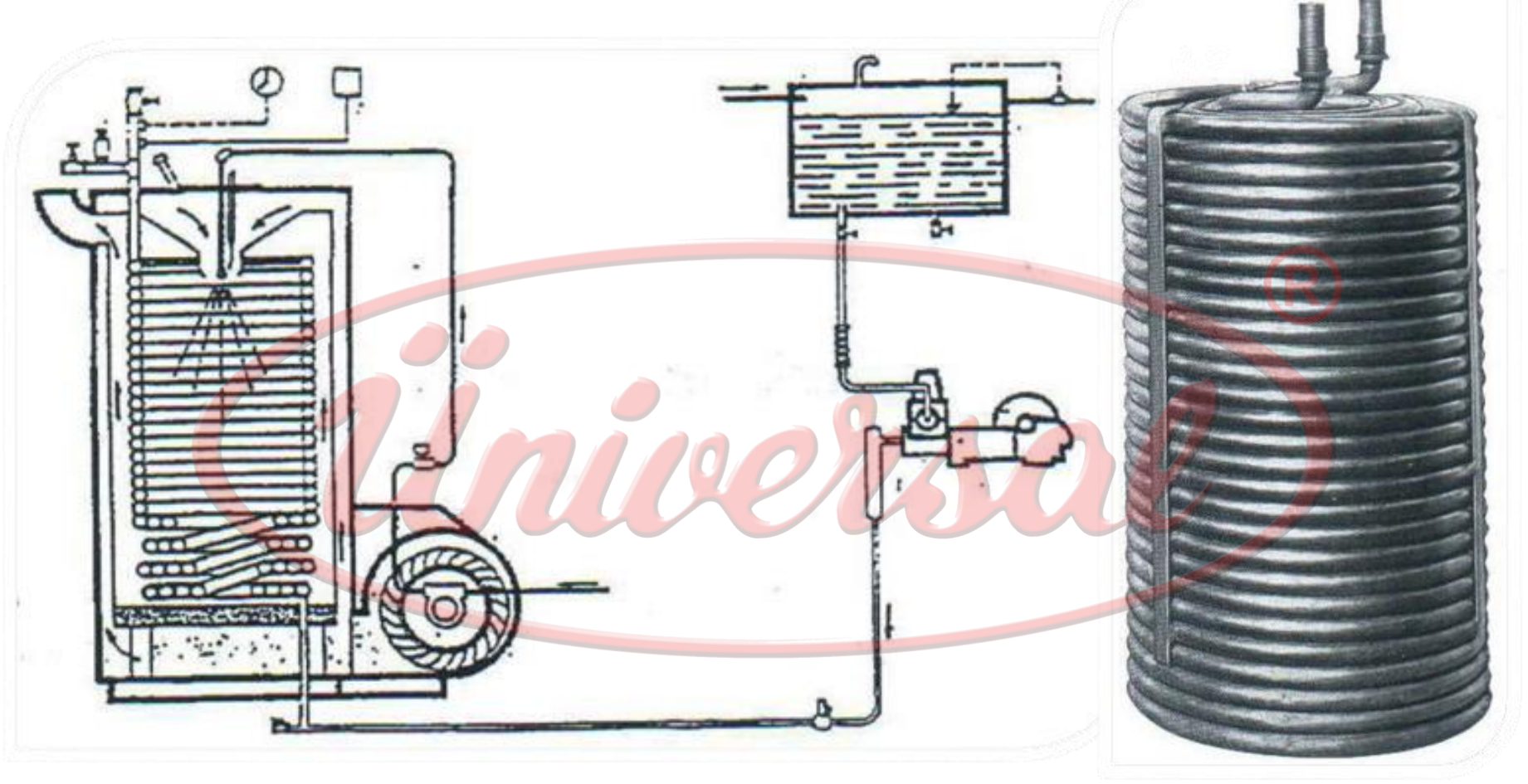

**Spiral water tube steam boiler**

# Boiler room flow diagram

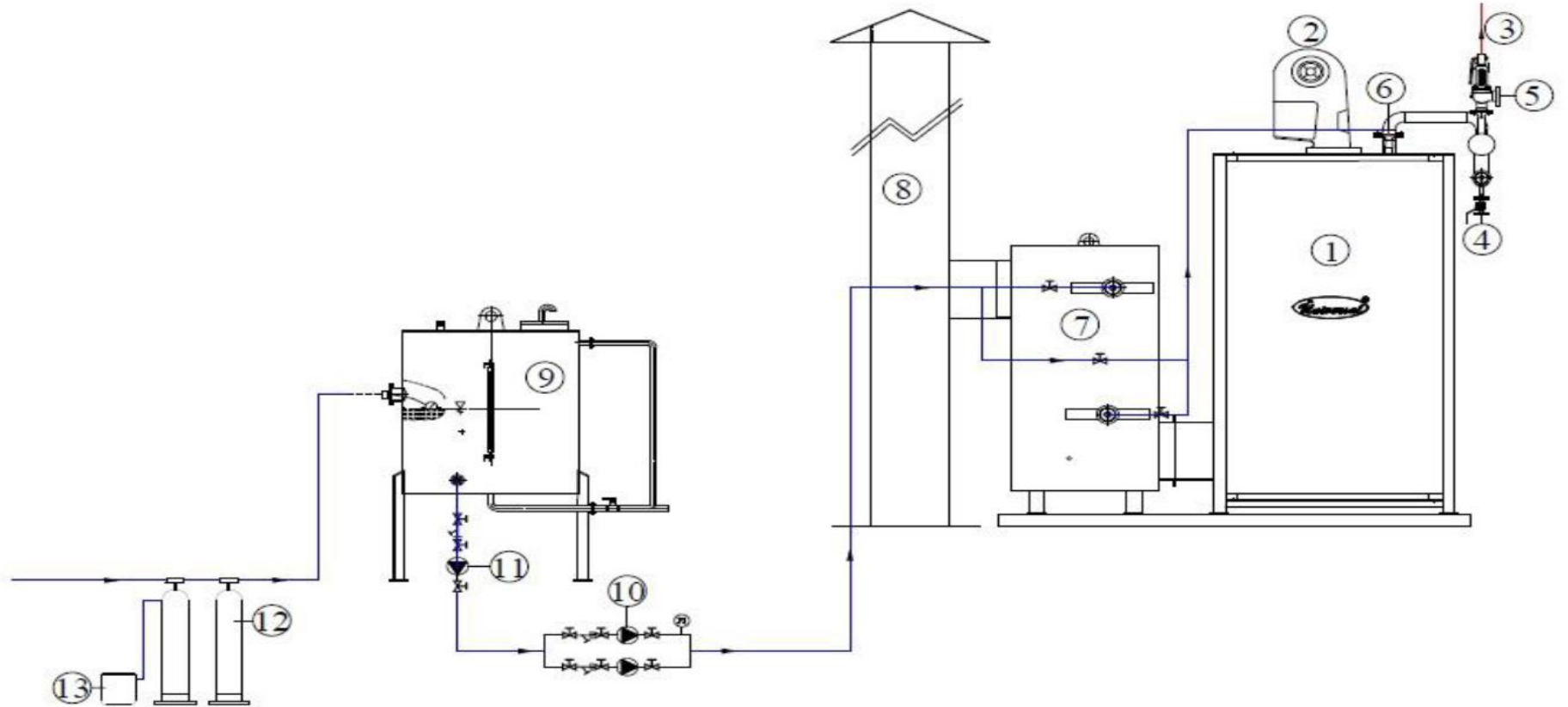



*Universal*®

## **Multi Cyclone Filter**

# Steam/Thermal Energy Using Sectors

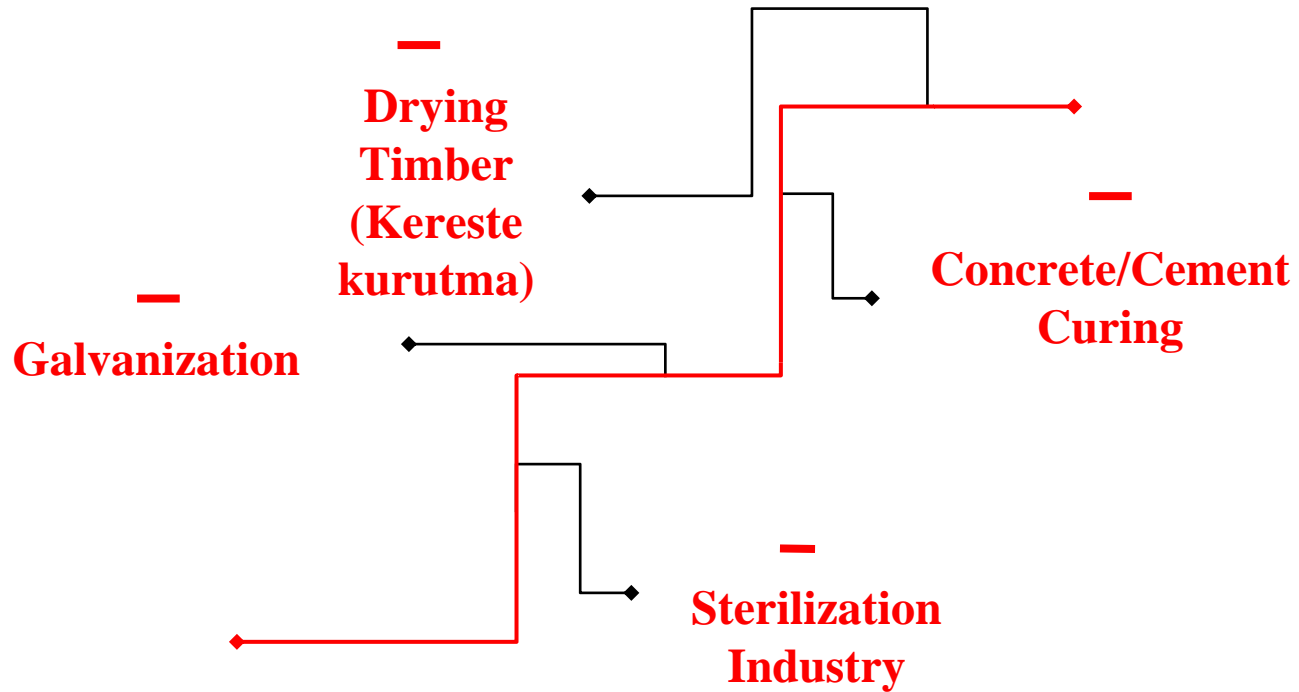

# Steam/Thermal Energy Using Sectors

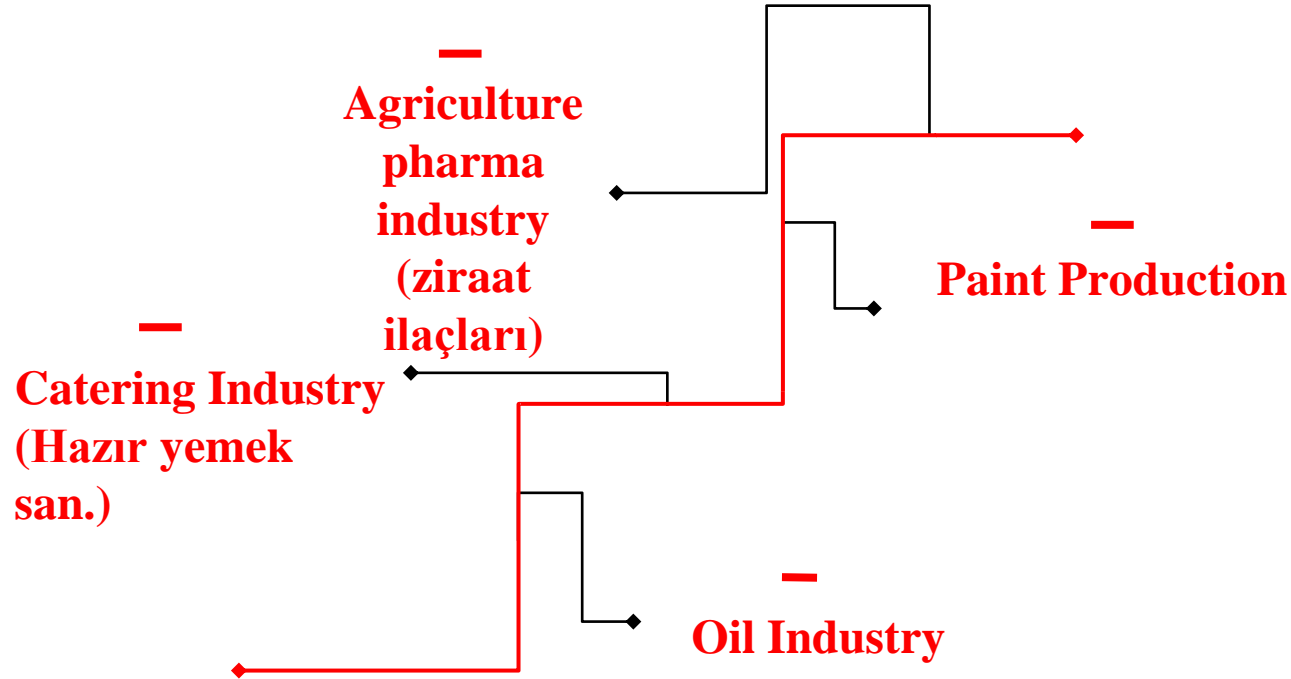

# Steam/Thermal Energy Using Sectors

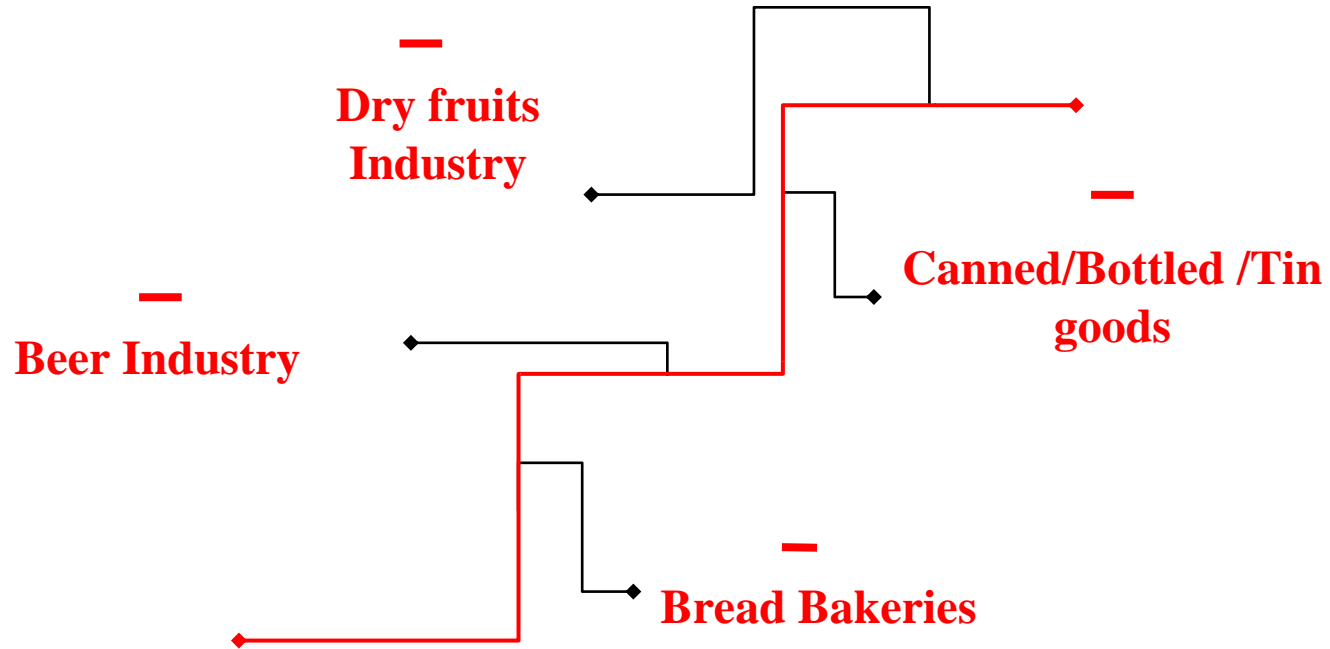

# Steam/Thermal Energy Using Sectors

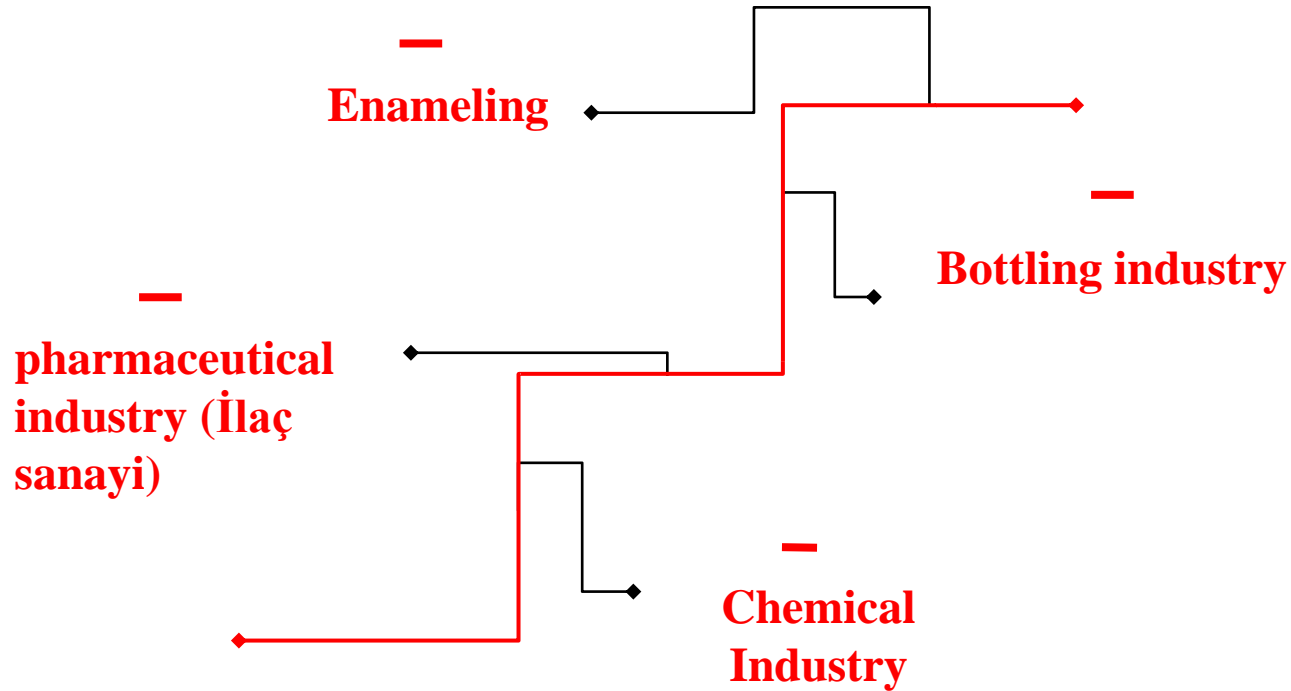

# Steam/Thermal Energy Using Sectors

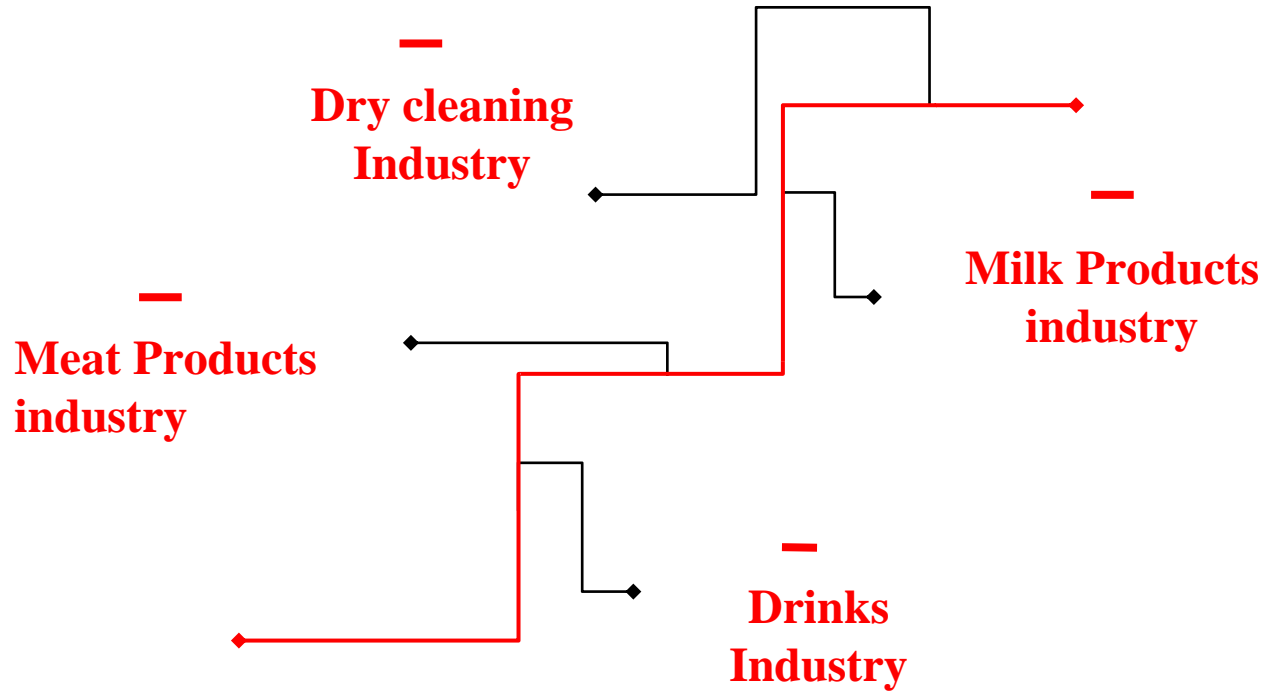



# Steam/Thermal Energy Using Sectors

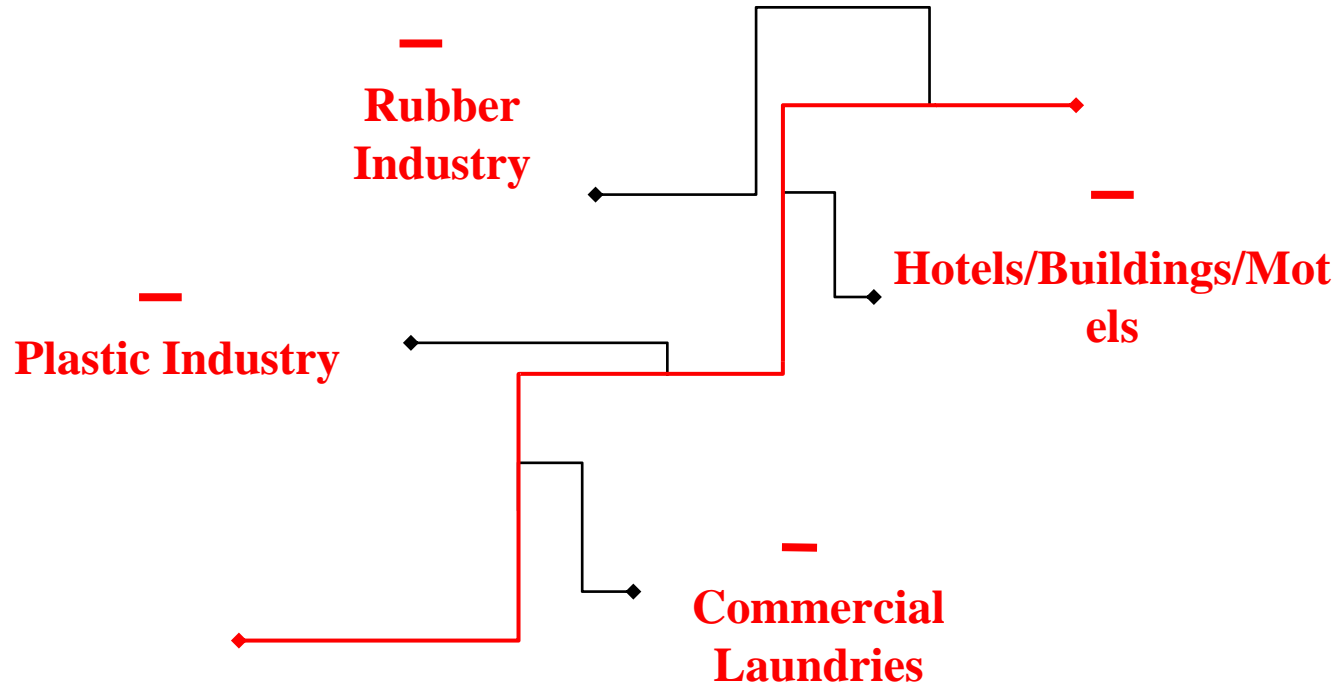

# Steam/Thermal Energy Using Sectors

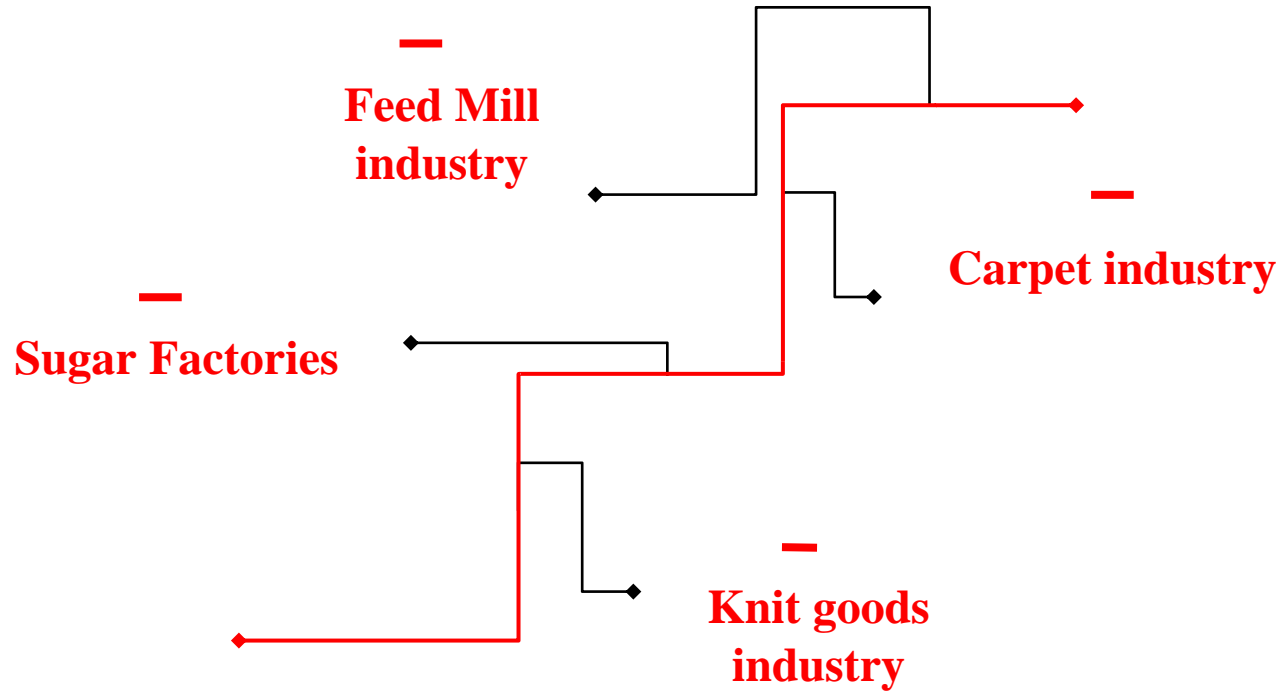

# Steam/Thermal Energy Using Sectors

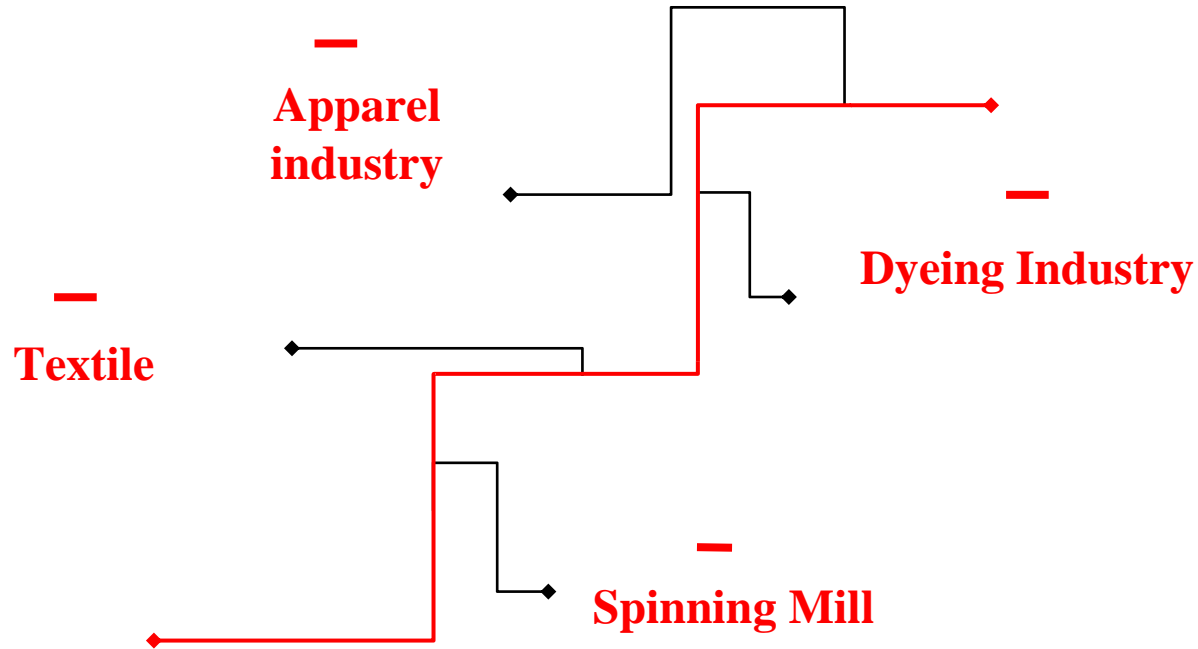

# Steam/Thermal Energy Using Sectors

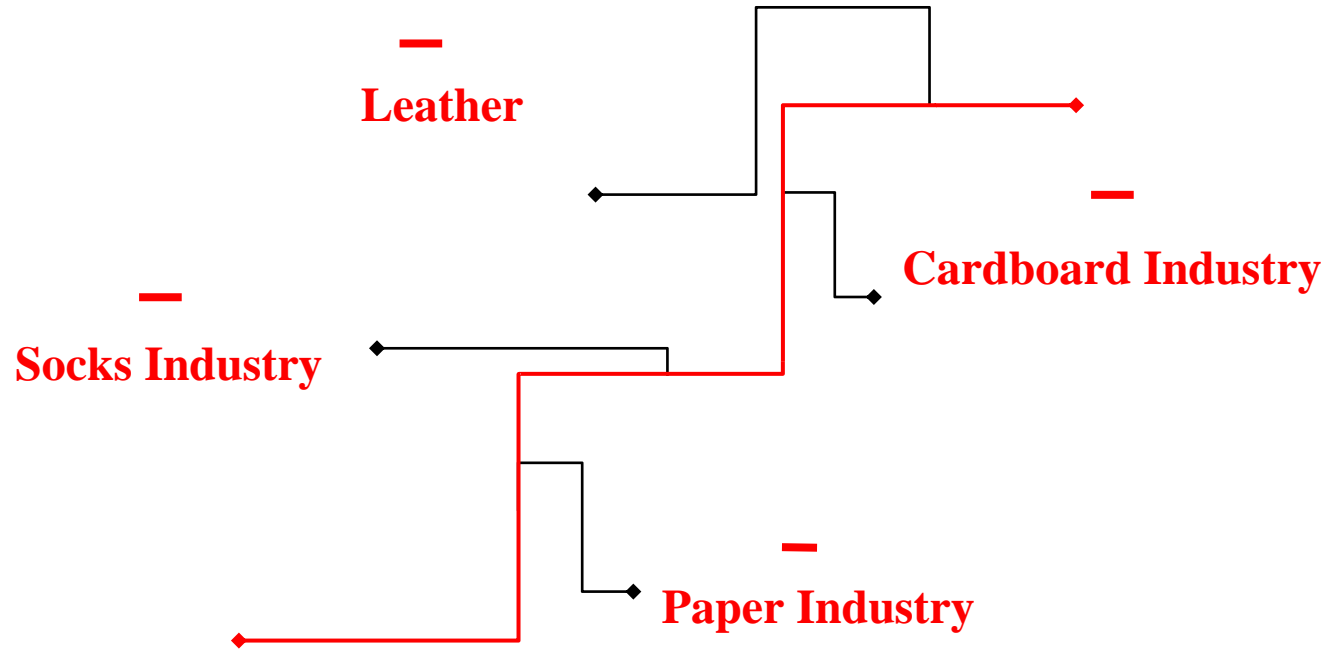

# Contact Information

**ÜNİVERSAL KAZAN PAZ.VE TAAH.LTD.ŞTİ.**

**Address :** İkitelli O.S.B.Metal-iş Sanayi Sitesi , Road 8. No.

36

**BAŞAKŞEHİR / İSTANBUL / TURKEY**

**Phone Number :** +90 212 549 7070

**Website :** [www.universalkazan.com.tr](http://www.universalkazan.com.tr)

**General Manager :** Gülcan Yalçın , +90 533 476 48 43 ,  
[gulcan@universalkazan.com](mailto:gulcan@universalkazan.com)

**Sales Responsible :** Ahmad Ali , +90 546 539 18 70 ,  
[a.ali@universalkazan.com](mailto:a.ali@universalkazan.com)

